



ITM



2022 CATALOG

"ANYTHING THAT MAKES A HOLE"[®]

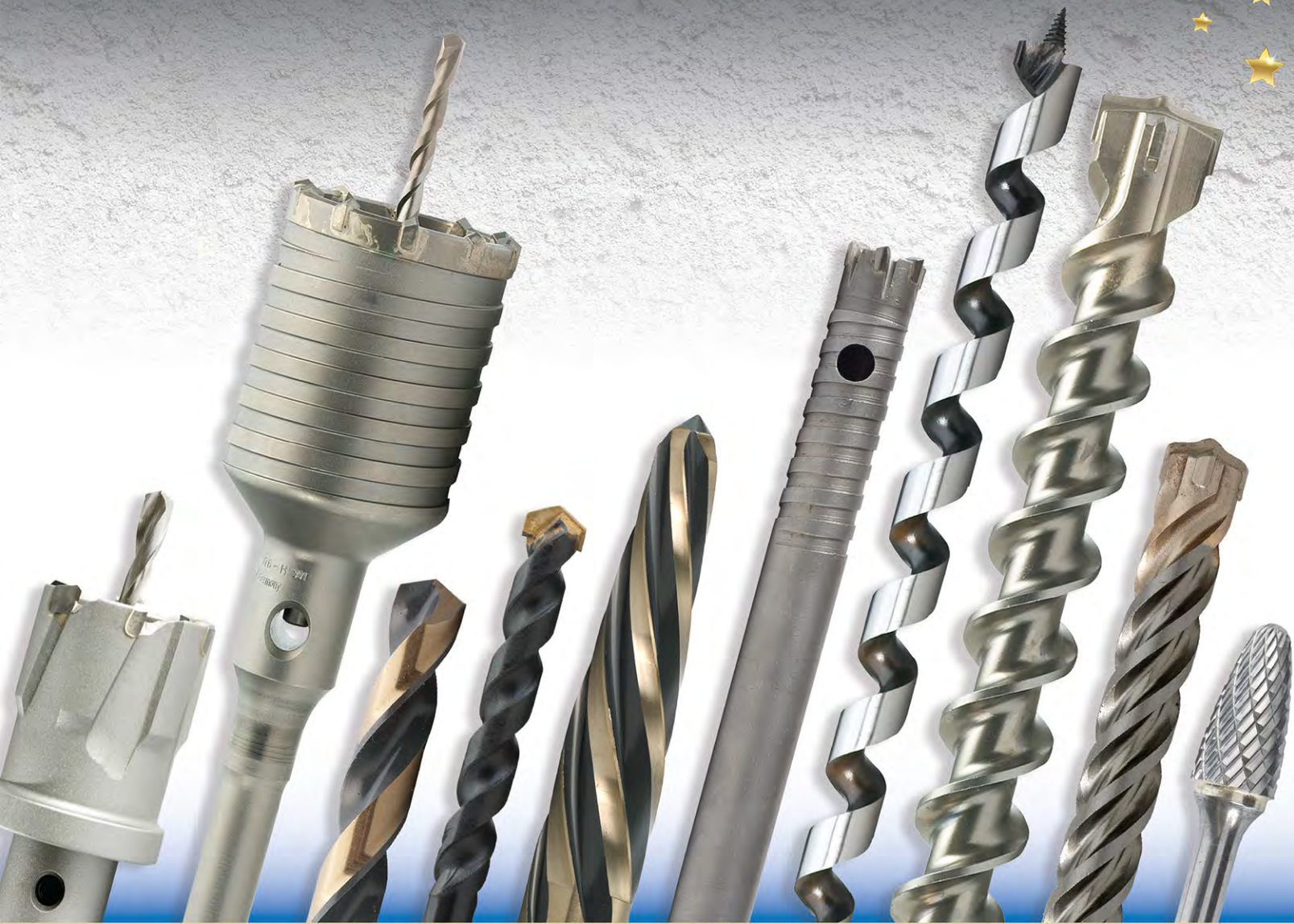

CONSTRUCTION DRILLING AND CUTTING SOLUTIONS

WWW.ITMTOOLS.COM | (800) 247-5696 | SALES@ITMTOOLS.COM



100% LAB TESTED

FAST DELIVERY

4000 items and 99% of all orders are shipped the same day if received before 3 P.M. Eastern Time.

EASY ORDERING

Order toll free, by fax, or email, either by part number or description. Our staff will quickly help you decide which product best fits your application. Order what you need, there is never a minimum order.

COMPLETE SATISFACTION

Simple: all of your purchases must satisfy you completely, or we will issue you a refund, exchange, or credit.

ITM catalogs are always made with YOU in mind! We hope you find our catalog easy to use and our staff a valuable resource for your business.

Thank you for your business and patronage.

Call us. We are here to make your life a little bit easier.

Sincerely yours,

Berardo Paradiso
President - ITM Corp.

Alberic Paradiso

Bryan Markell

Alex Teitelbaum

Chun Keat

Marilyn Rodriguez

Annette Kempadoo



p.10 Two Tone Jobbers HSS 118° Point



p.10 Bright Finish Jobbers HSS 118° Point



p.11 Black Oxide Jobbers HSS 118° Point



p.11 Black Oxide Wire Gauge HSS 118° Point



p.12 Black Oxide Jobbers HSS 135° Split Point



p.12 Black Oxide Wire Gauge HSS 135° Split Point



p.13 Black Oxide Letter HSS 135° Split Point



p.13 Black Oxide Metric HSS 118° Point



p.14 Black Oxide Stub Length HSS 135° Split Point



p.15 Black Oxide Silver & Deming HSS 118° Point

BLACK
Oxide



p.17 Black & Gold Jobbers HSS 135° Split Point



p.17 Black & Gold Wire Gauge HSS 135° Split Point



p.18 Black & Gold Mechanics Length HSS 135° Split Point



p.19 Black & Gold Letter Size HSS 135° Split Point



p.19 Black & Gold Silver & Deming HSS 118° Split Point



p.20 MRO Black & Gold Jobbers 135° Split Point



p.20 MRO Black & Gold Letter Size HSS 135° Split Point



p.21 MRO Black & Gold Wire Gauge 135° Split Point

Black & Gold



p.22 Cobalt Jobbers 135° Split Point



p.22 Cobalt Wire Gauge 135° Split Point



p.23 Cobalt Stub Length 135° Split Point



p.23 Cobalt Silver & Deming 118° Split Point

COBALT



p.24 Titanium (TiN) Jobbers HSS 135° Split Point



p.24 1/4" Hex Impact Titanium (TiN) Jobbers
HSS 135° Split Point

NEW!



p.25 Parabolic Jobbers 135° Split Point



p.25 Cobalt Jobbers 135° Split Point



p.26 Spotweld Double End Drills



p.26 Double End Drills 135° Split Point



p.26 Screw Extractors



p.27 Aircraft HSS 135° Split Point (6", 12" & 18" Long)



p.28 Bullet Case Drill Bit Sets / HUOT Case Drill Bit Sets



p.30 Tap & Drill Sets / 525 Pc. Dispenser

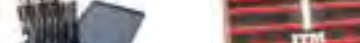



Countersinks - Zero Flute Countersinks

p.32



Rim Champ Inner Reamer

p.32



Bar Champ Outer Reamer

p.33



Pipe Taps, NPT

p.35



Hand Tap Wrenches

p.35

Hand Taps, Carbon Steel

p.36

Hand Taps, HSS

p.37

Combo Drill Taps

p.38

Spiral Point (Gun) Taps

p.38

3 in 1 Combo Drill Taps

p.39



Wire Brushes

p.40



Burs - Solid Carbide / Kit

p.42



Step Drills HSS

p.44



Reamers

p.46+



VIP-STEP Jobber Drill

p.49



Annular Twist Drill HSS

p.50



Annular Cutters HSS / Kit

p.50



Magnetic Drill Accessories
Drill Taps, Countersinks & Chucks

p.52



Step Reamers / Kit

p.53



T.C.T. Hole Cutters

p.54



Hole Saws - Bi-Metal

p.57

Hole Saws - Carbide Tipped

p.58

Hole Saws - Carbide Grit

p.59

Pilot Drills and Accessories

p.60



Arbors

p.61





p.62 Reciprocating Blades - Bi-Metal - Wood & Metal



p.63 Reciprocating Blades - Bi-Metal Heavy Metal, Carbide & Demolition



p.65 Hack-Saw Blades - Bi-Metal



p.65 Band-Saw Blades - Bi-Metal



p.65 Drywall Cutter



p.66 Reciprocating Blades - Bi-Metal - Retail Packs



p.68 Oscillating Blades - Bi-Metal

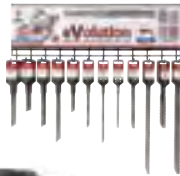

p.70+ Retail Ready Displays / Standard Displays



p.73 Electrician's Flex Bit (Stretch Bit)



p.73 Circular Saw Blades - Wood



p.74 Bell Hanger Drills (Fish Hole Drills) HSS & Carbide Tipped



p.75 Long Boy Drills HSS (12" & 18")



p.75 Brad Point Wood Drills



p.76 Spade Drills



p.77 Self Feed (Multispur) Wood Drills



p.77 Extensions (For Ship Augers / Multispur)



p.78 Power Pole Auger Drills



p.79 Ship Auger Wood Drills (8" & 18" Long)



p.80 V Groove Tile Bit



p.81 V Groove Bathroom Install Kit

p.81 V Screw 101 Pc. Stainless Screws



p.82 White Diamond Tile Bit



- Diamond Milling & Countersink
- Glass Drills
- Blu Diamond Tile Bit
- Multi Purpose Drills
- Hard Steel Drills - Left & Right Hand
- Masonry Drills - Black Oxide - Slow Spiral
- Carpet Tack Strip Stub Drills
- Roto Percussion Masonry Drills
- SDS-PLUS Redline
- SDS-PLUS Redline X-Cutter
- SDS-MAX Redline Chisels
- SDS-PLUS Bohr Hammer
- SDS-PLUS Evolution
- SDS-PLUS X-Cutter
- SPLINE Rotary Hammer Drills
- SDS-MAX Rotary Hammer Drills
- Extension Systems / Adapters
- SDS-MAX Tunnel Bore
- Ratio Core System
- Core Bits - SDS-MAX Taper Shanks
- Core Bits - SDS-MAX 1 Piece
- SDS-PLUS Diamond Core
- SDS-PLUS Lightweight Core
- Dry Diamond Core
- Stone Countertops
- Wet Diamond Core





p.110 Duster Rotary Hammer Drills (HEPA Vacuums)



p.111 Dust Pro Cups (HEPA Vacuums)



p.112 SDS-PLUS Stop (For Drop In Anchors)



p.112 SDS-Plus Adapters



p.113 Concrete Screw Drills



p.113 SDS-Plus HEX for Concrete Screws



p.113 Concrete Screw Sleeve / Concrete Screw Kit



p.114 Rebar Cutters



p.116 SDS-MAX, SDS-PLUS & Spline Chisels - MINI Chisels

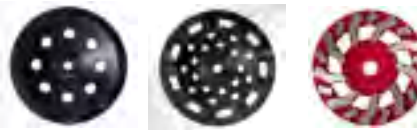

p.118 PCD Cup Wheel - Diamond Grinding Cup Wheel



p.119+ Diamond Cutting Wheels And Tuck Points



p.122+ Screwdriver Insert Bits



p.128 Bit Holders



p.130 Sockets (Magnetic Impact) & Drivers



p.131 Nut Setters - Magnetic / Impact Protection



p.132 Insert Bit Sets & MEGAPRO Screwdriver



p.134 Cable Ties



p.135 Plastic Anchor Kits - Metal Anchors



p.132 Utility Knives and Accessories



expertise

because drilling solutions



can be out of the ordinary

Terms Of Sale

- Terms:** 2% 10 Days, Net 30 Days. All credit cards welcome.
- Credit:** Open account privileges are extended to any firm that is satisfactorily rated. New accounts should submit at least 3 commercial references including all contact information and their tax resale number.
- Quantities:** Although there is no minimum purchase order, we reserve the right to adjust any order to the minimum packaged quantities indicated in catalog.
- Claims:** Should be made within 15 days of receipts.
- Freight:** Prepaid for NET invoices equaling \$600 or more.

EFFECTIVE NOVEMBER 2021.





HSS TOOL DATA

Suggested Drill Bits To Be Used For Various Types Of Materials:

MATERIAL	DRILL STYLE	ANGLE POINT	PRESSURE TO APPLY	COOLANT OR LUBRICANT
CARBON STEEL DUCTILE STEEL BRASS BRONZE	GENERAL PURPOSE DRILLS	118° POINT	MEDIUM TO HEAVY	OIL or WATER SOLUTION
CARBON STEEL ALUMINUM AUSTENITIC STAINLESS STEEL	HEAVY DUTY AND TITANIUM	135° SPLIT POINT	MEDIUM TO HEAVY	OIL or ACTIVATED SOLUTION
STAINLESS STEEL SERIES C CAST IRON	COBALT DRILLS	135° SPLIT POINT	MEDIUM TO HEAVY	OIL or ACTIVATED SOLUTION
HARD STEEL HEAT TREATED ALLOYS	HARD BODY CARBIDE TIPPED AND COBALT	130° & 135° SPLIT POINT	HEAVY	OIL or ACTIVATED SOLUTION

Chemical Analysis Of The Three Primary High Speed Steels Used To Manufacture HSS Drill Bits:

TYPE	CHEMICAL COMPOSITION						ROCKWELL C HARDNESS	TERM
	CARBON	TUNGSTEN	MOLYBDENUM	CHROMIUM	VANADIUM	COBALT		
M2	0.85	6.00	5.00	4.00	1.90	-	63-65	HSS
M35	1.10	1.50	9.50	1.15	1.15	5.00	65-67	COBALT
M42	1.10	1.50	9.50	1.15	1.15	8.00	65-67	SUPER COBALT

M2 "HSS" is the standard material used for all **ITM** drill bits. M2 has good red-hardness and retains its cutting edge longer than other general purpose high speed steels because of its increased quantity of tungsten (dull red heat up to 1000° F without loss of hardness or rapid dulling of cutting edge). M2 is generally favored for high production machine work.

M35 M35 is the standard cobalt material used for most **ITM** cobalt drill bits. M35 has excellent resistance to abrasion and very good red-hardness for working difficult materials.

M42 M42 "Super Cobalt" is American made premium cobalt material used for higher performance **ITM** cobalt drill bits. M42 has the best resistance to abrasion and red-hardness.

COBALT DRILLS

Made of the finest Cobalt steel obtainable and furnished with a 135° split point, these drills are designed for use in machining hard, tough materials beyond the normal cutting capabilities of regular high speed steel tools. These include work-hardening grades of stainless steels, titanium, high temperature alloys, and many other heat treated materials. In addition, due to their resistant properties, they can also be used at higher speeds to drill abrasive plastics, cast iron, and other types of difficult to machine work materials.



Always Use Protection When Drilling.

Always Use High RPM For Smaller Diameters and Lower RPM For Larger Diameters.

HSS TOOL DATA

Understanding High Speed Steel Drill Bits:

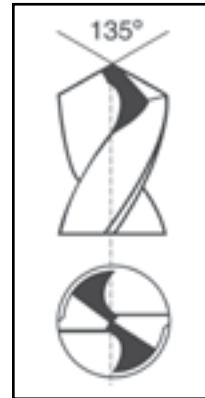
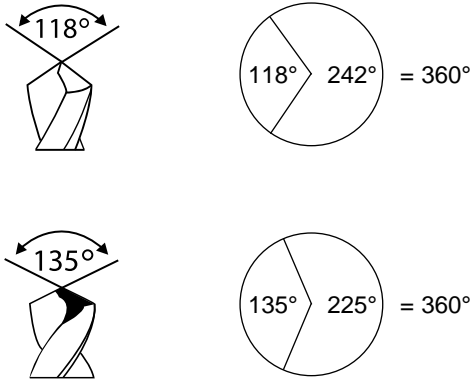

Split Point

An extra cutting angle on the 2 cutting edges of a drill bit.

Split Point is designated here in black.

Split Pointing is almost always reserved for 135° HSS drill bits.

118° drill bits have a sharp point and are common on standard / general purpose drill bits where light duty work is needed. Because of this sharp point, 118° drill bits will tend to “walk” or spin like a top on flat surfaces. This is why a centering drill or center punch is normally used to start off holes. If the operator has very steady hands, then the 118° drill bit can be used without center punching.

135° drill bits have a flatter point which gives the drill bit more cutting surface area. When more surface area cuts the steel, drilling is faster.



Understanding Nomenclature Vis-a-vis Size:

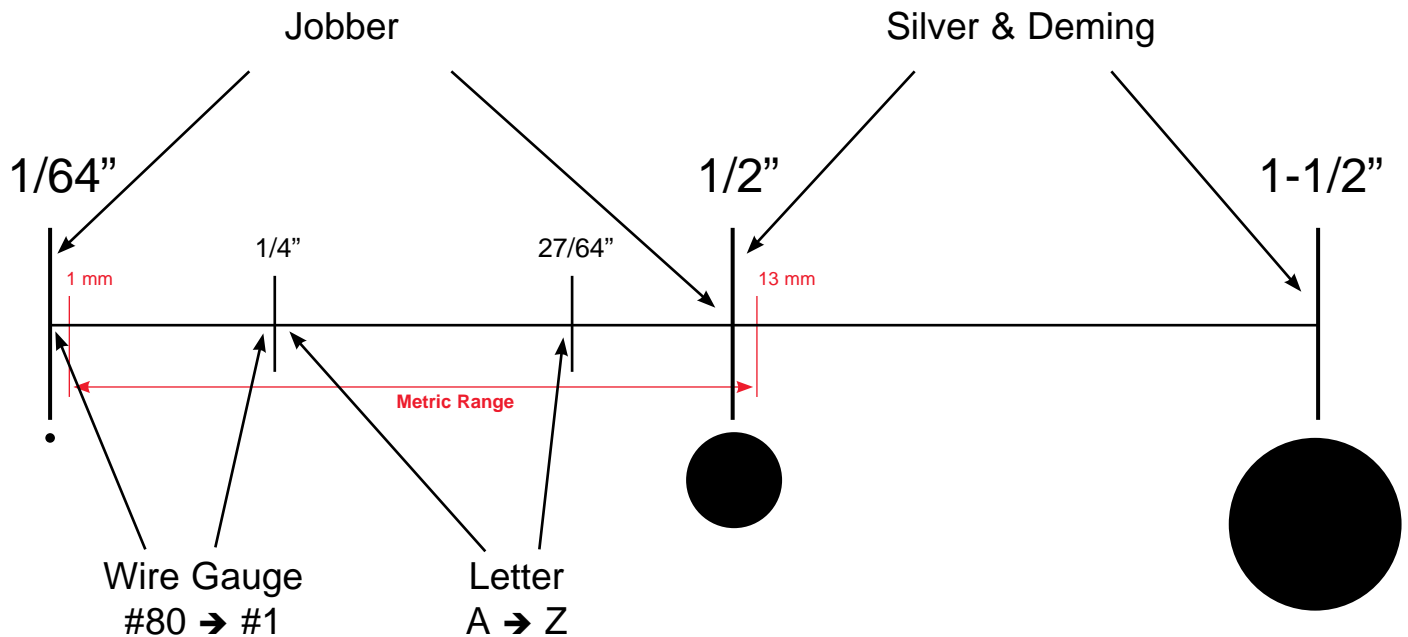

Chart Not To Scale.



Jobber Drills - General Purpose - TWO TONE FINISH M2 HSS



- ◆ Jobber Length
- ◆ 118° Point
- ◆ General Purpose
- ◆ Roll Forged
- ◆ Straight Shank
- ◆ Two Tone Finish
- ◆ M2 HSS



Part #	Size	Dec.	OAL	Flute	Qty.	Part #	Size	Dec.	OAL	Flute	Qty.
200HS0464	1/16"	.0625	1-7/8"	7/8"	12	200HS1964	19/64"	.2969	4-3/8"	3-1/16"	12
200HS0564	5/64"	.0781	2"	1"	12	200HS2064	5/16"	.3125	4-1/2"	3-3/16"	12
200HS0664	3/32"	.0938	2-1/4"	1-1/4"	12	200HS2164	21/64"	.3281	4-5/8"	3-5/16"	6
200HS0764	7/64"	.1094	2-5/8"	1-1/2"	12	200HS2264	11/32"	.3438	4-3/4"	3-7/16"	6
200HS0864	1/8"	.1250	2-3/4"	1-5/8"	12	200HS2364	23/64"	.3594	4-7/8"	3-1/2"	6
200HS0964	9/64"	.1406	2-7/8"	1-3/4"	12	200HS2464	3/8"	.3750	5"	3-5/8"	6
200HS1064	5/32"	.1562	3-1/8"	2"	12	200HS2564	25/64"	.3906	5-1/8"	3-3/4"	6
200HS1164	11/64"	.1719	3-1/4"	2-1/8"	12	200HS2664	13/32"	.4062	5-1/4"	3-1/8"	6
200HS1264	3/16"	.1875	3-1/2"	2-5/16"	12	200HS2764	27/64"	.4219	5-3/8"	3-15/16"	6
200HS1364	13/64"	.2031	3-5/8"	2-7/16"	12	200HS2864	7/16"	.4375	5-1/2"	4-1/16"	6
200HS1464	7/32"	.2188	3-3/4"	2-1/2"	12	200HS2964	29/64"	.4531	5-5/8"	4-3/16"	6
200HS1564	15/64"	.2344	3-7/8"	2-5/8"	12	200HS3064	15/32"	.4688	5-3/4"	4-5/16"	6
200HS1664	1/4"	.2500	4"	2-3/4"	12	200HS3164	31/64"	.4844	5-7/8"	4-3/8"	6
200HS1764	17/64"	.2656	4-1/8"	2-7/8"	12	200HS3264	1/2"	.5000	6"	4-1/2"	6
200HS1864	9/32"	.2812	4-1/4"	2-15/16"	12						



Jobber Drills - General Purpose - BRIGHT FINISH M2 HSS



- ◆ Jobber Length
- ◆ 118° Point
- ◆ General Purpose
- ◆ Ground Flute
- ◆ Straight Shank
- ◆ Bright Finish
- ◆ M2 HSS



Part #	Size	Dec.	OAL	Flute	Qty.	Part #	Size	Dec.	OAL	Flute	Qty.
250US0164	1/64"	.0156	3/4"	3/16"	12	250US1764	17/64"	.2656	4-1/8"	2-7/8"	12
250US0264	1/32"	.0312	1-3/8"	1/2"	12	250US1864	9/32"	.2812	4-1/4"	2-15/16"	12
250US0364	3/64"	.0469	1-3/4"	3/4"	12	250US1964	19/64"	.2969	4-3/8"	3-1/16"	12
250US0464	1/16"	.0625	1-7/8"	7/8"	12	250US2064	5/16"	.3125	4-1/2"	3-3/16"	12
250US0564	5/64"	.0781	2"	1"	12	250US2164	21/64"	.3281	4-5/8"	3-5/16"	6
250US0664	3/32"	.0938	2-1/4"	1-1/4"	12	250US2264	11/32"	.3438	4-3/4"	3-7/16"	6
250US0764	7/64"	.1094	2-5/8"	1-1/2"	12	250US2364	23/64"	.3594	4-7/8"	3-1/2"	6
250US0864	1/8"	.1250	2-3/4"	1-5/8"	12	250US2464	3/8"	.3750	5"	3-5/8"	6
250US0964	9/64"	.1406	2-7/8"	1-3/4"	12	250US2564	25/64"	.3906	5-1/8"	3-3/4"	6
250US1064	5/32"	.1562	3-1/8"	2"	12	250US2664	13/32"	.4062	5-1/4"	3-1/8"	6
250US1164	11/64"	.1719	3-1/4"	2-1/8"	12	250US2764	27/64"	.4219	5-3/8"	3-15/16"	6
250US1264	3/16"	.1875	3-1/2"	2-5/16"	12	250US2864	7/16"	.4375	5-1/2"	4-1/16"	6
250US1364	13/64"	.2031	3-5/8"	2-7/16"	12	250US2964	29/64"	.4531	5-5/8"	4-3/16"	6
250US1464	7/32"	.2188	3-3/4"	2-1/2"	12	250US3064	15/32"	.4688	5-3/4"	4-5/16"	6
250US1564	15/64"	.2344	3-7/8"	2-5/8"	12	250US3164	31/64"	.4844	5-7/8"	4-3/8"	6
250US1664	1/4"	.2500	4"	2-3/4"	12	250US3264	1/2"	.5000	6"	4-1/2"	6



Jobber Drills - General Purpose - BLACK FINISH M2 HSS

Part #	Size	Dec.	OAL	Flute	Qty.	Part #	Size	Dec.	OAL	Flute	Qty.
200BF0464	1/16"	.0625	1-7/8"	7/8"	12	200BF1964	19/64"	.2969	4-3/8"	3-1/16"	12
200BF0564	5/64"	.0781	2"	1"	12	200BF2064	5/16"	.3125	4-1/2"	3-3/16"	12
200BF0664	3/32"	.0938	2-1/4"	1-1/4"	12	200BF2164	21/64"	.3281	4-5/8"	3-5/16"	6
200BF0764	7/64"	.1094	2-5/8"	1-1/2"	12	200BF2264	11/32"	.3438	4-3/4"	3-7/16"	6
200BF0864	1/8"	.1250	2-3/4"	1-5/8"	12	200BF2364	23/64"	.3594	4-7/8"	3-1/2"	6
200BF0964	9/64"	.1406	2-7/8"	1-3/4"	12	200BF2464	3/8"	.3750	5"	3-5/8"	6
200BF1064	5/32"	.1562	3-1/8"	2"	12	200BF2564	25/64"	.3906	5-1/8"	3-3/4"	6
200BF1164	11/64"	.1719	3-1/4"	2-1/8"	12	200BF2664	13/32"	.4062	5-1/4"	3-7/8"	6
200BF1264	3/16"	.1875	3-1/2"	2-5/16"	12	200BF2764	27/64"	.4219	5-3/8"	3-15/16"	6
200BF1364	13/64"	.2031	3-5/8"	2-7/16"	12	200BF2864	7/16"	.4375	5-1/2"	4-1/16"	6
200BF1464	7/32"	.2188	3-3/4"	2-1/2"	12	200BF2964	29/64"	.4531	5-5/8"	4-3/16"	6
200BF1564	15/64"	.2344	3-7/8"	2-5/8"	12	200BF3064	15/32"	.4688	5-3/4"	4-5/16"	6
200BF1664	1/4"	.2500	4"	2-3/4"	12	200BF3164	31/64"	.4844	5-7/8"	4-3/8"	6
200BF1764	17/64"	.2656	4-1/8"	2-7/8"	12	200BF3264	1/2"	.5000	6"	4-1/2"	6
200BF1864	9/32"	.2812	4-1/4"	2-15/16"	12						



- ◆ Jobber Length
- ◆ 118° Point
- ◆ General Purpose
- ◆ Roll Forged
- ◆ Straight Shank
- ◆ Black Oxide Finish
- ◆ M2 HSS



Wire Gauge Drills - General Purpose - BLACK FINISH M2 HSS

Part #	Size	Dec.	OAL	Flute	Qty.	Part #	Size	Dec.	OAL	Flute	Qty.
203HS0001	1	.2280	3-7/8"	2-5/8"	12	203HS0031	31	.1200	2-3/4"	1-5/8"	12
203HS0002	2	.2210	3-7/8"	2-5/8"	12	203HS0032	32	.1160	2-3/4"	1-5/8"	12
203HS0003	3	.2130	3-3/4"	2-1/2"	12	203HS0033	33	.1130	2-5/8"	1-1/2"	12
203HS0004	4	.2090	3-3/4"	2-1/2"	12	203HS0034	34	.1110	2-5/8"	1-1/2"	12
203HS0005	5	.2055	3-3/4"	2-1/2"	12	203HS0035	35	.1100	2-5/8"	1-1/2"	12
203HS0006	6	.2040	3-3/4"	2-1/2"	12	203HS0036	36	.1065	2-1/2"	1-7/16"	12
203HS0007	7	.2010	3-5/8"	2-7/16"	12	203HS0037	37	.1040	2-1/2"	1-7/16"	12
203HS0008	8	.1990	3-5/8"	2-7/16"	12	203HS0038	38	.1015	2-1/2"	1-7/16"	12
203HS0009	9	.1960	3-5/8"	2-7/16"	12	203HS0039	39	.0995	2-3/8"	1-3/8"	12
203HS0010	10	.1935	3-5/8"	2-7/16"	12	203HS0040	40	.0980	2-3/8"	1-3/8"	12
203HS0011	11	.1910	3-1/2"	2-5/16"	12	203HS0041	41	.0960	2-3/8"	1-3/8"	12
203HS0012	12	.1890	3-1/2"	2-5/16"	12	203HS0042	42	.0935	2-1/4"	1-1/4"	12
203HS0013	13	.1850	3-1/2"	2-5/16"	12	203HS0043	43	.0890	2-1/4"	1-1/4"	12
203HS0014	14	.1820	3-3/8"	2-3/16"	12	203HS0044	44	.0860	2-1/8"	1-1/8"	12
203HS0015	15	.1800	3-3/8"	2-3/16"	12	203HS0045	45	.0820	2-1/8"	1-1/8"	12
203HS0016	16	.1770	3-3/8"	2-3/16"	12	203HS0046	46	.0810	2-1/8"	1-1/8"	12
203HS0017	17	.1730	3-3/8"	2-3/16"	12	203HS0047	47	.0785	2"	1"	12
203HS0018	18	.1695	3-1/4"	2-1/8"	12	203HS0048	48	.0760	2"	1"	12
203HS0019	19	.1660	3-1/4"	2-1/8"	12	203HS0049	49	.0730	2"	1"	12
203HS0020	20	.1610	3-1/4"	2-1/8"	12	203HS0050	50	.0700	2"	1"	12
203HS0021	21	.1590	3-1/4"	2-1/8"	12	203HS0051	51	.0670	2"	1"	12
203HS0022	22	.1570	3-1/8"	2"	12	203HS0052	52	.0635	1-7/8"	7/8"	12
203HS0023	23	.1540	3-1/8"	2"	12	203HS0053	53	.0595	1-7/8"	7/8"	12
203HS0024	24	.1520	3-1/8"	2"	12	203HS0054	54	.0550	1-7/8"	7/8"	12
203HS0025	25	.1495	3"	1-7/8"	12	203HS0055	55	.0520	1-7/8"	7/8"	12
203HS0026	26	.1470	3"	1-7/8"	12	203HS0056	56	.0465	1-3/4"	3/4"	12
203HS0027	27	.1440	3"	1-7/8"	12	203HS0057	57	.0430	1-3/4"	3/4"	12
203HS0028	28	.1405	2-7/8"	1-3/4"	12	203HS0058	58	.0420	1-5/8"	11/16"	12
203HS0029	29	.1360	2-7/8"	1-3/4"	12	203HS0059	59	.0410	1-5/8"	11/16"	12
203HS0030	30	.1285	2-3/4"	1-5/8"	12	203HS0060	60	.0400	1-5/8"	11/16"	12

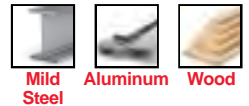

- ◆ Wire Gauge
- ◆ 118° Point
- ◆ General Purpose
- ◆ Roll Forged
- ◆ Straight Shank
- ◆ Black Oxide Finish
- ◆ M2 HSS



AVAILABLE:
SIZES 61 → 80



BLACK
Oxide



Jobber Drills - HEAVY DUTY - BLACK OXIDE FINISH M2 HSS

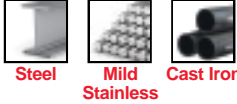

- ◆ Jobber Length
- ◆ 135° Split Point
- ◆ Ground Flute
- ◆ Straight Shank
- ◆ Heavy Duty Web
- ◆ Black Oxide Finish
- ◆ M2 HSS



Part #	Size	Dec.	OAL	Flute	Qty.	Part #	Size	Dec.	OAL	Flute	Qty.
206SP0464	1/16"	.0625	1-7/8"	7/8"	12	206SP1964	19/64"	.2969	4-3/8"	3-1/16"	12
206SP0564	5/64"	.0781	2"	1"	12	206SP2064	5/16"	.3125	4-1/2"	3-3/16"	12
206SP0664	3/32"	.0938	2-1/4"	1-1/4"	12	206SP2164	21/64"	.3281	4-5/8"	3-5/16"	6
206SP0764	7/64"	.1094	2-5/8"	1-1/2"	12	206SP2264	11/32"	.3438	4-3/4"	3-7/16"	6
206SP0864	1/8"	.1250	2-3/4"	1-5/8"	12	206SP2364	23/64"	.3594	4-7/8"	3-1/2"	6
206SP0964	9/64"	.1406	2-7/8"	1-3/4"	12	206SP2464	3/8"	.3750	5"	3-5/8"	6
206SP1064	5/32"	.1562	3-1/8"	2"	12	206SP2564	25/64"	.3906	5-1/8"	3-3/4"	6
206SP1164	11/64"	.1719	3-1/4"	2-1/8"	12	206SP2664	13/32"	.4062	5-1/4"	3-7/8"	6
206SP1264	3/16"	.1875	3-1/2"	2-5/16"	12	206SP2764	27/64"	.4219	5-3/8"	3-15/16"	6
206SP1364	13/64"	.2031	3-5/8"	2-7/16"	12	206SP2864	7/16"	.4375	5-1/2"	4-1/16"	6
206SP1464	7/32"	.2188	3-3/4"	2-1/2"	12	206SP2964	29/64"	.4531	5-5/8"	4-3/16"	6
206SP1564	15/64"	.2344	3-7/8"	2-5/8"	12	206SP3064	15/32"	.4688	5-3/4"	4-5/16"	6
206SP1664	1/4"	.2500	4"	2-3/4"	12	206SP3164	31/64"	.4844	5-7/8"	4-3/8"	6
206SP1764	17/64"	.2656	4-1/8"	2-7/8"	12	206SP3264	1/2"	.5000	6"	4-1/2"	6
206SP1864	9/32"	.2812	4-1/4"	2-15/16"	12						



Wire Gauge Drills - HEAVY DUTY - BLACK OXIDE FINISH M2 HSS

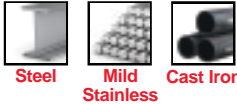

- ◆ Wire Gauge
- ◆ 135° Split Point
- ◆ Ground Flute
- ◆ Straight Shank
- ◆ Heavy Duty Web
- ◆ Black Oxide Finish
- ◆ M2 HSS



Part #	Size	Dec.	OAL	Flute	Qty.	Part #	Size	Dec.	OAL	Flute	Qty.
207SP0001	1	.2280	3-7/8"	2-5/8"	12	207SP0031	31	.1200	2-3/4"	1-5/8"	12
207SP0002	2	.2210	3-7/8"	2-5/8"	12	207SP0032	32	.1160	2-3/4"	1-5/8"	12
207SP0003	3	.2130	3-3/4"	2-1/2"	12	207SP0033	33	.1130	2-5/8"	1-1/2"	12
207SP0004	4	.2090	3-3/4"	2-1/2"	12	207SP0034	34	.1110	2-5/8"	1-1/2"	12
207SP0005	5	.2055	3-3/4"	2-1/2"	12	207SP0035	35	.1100	2-5/8"	1-1/2"	12
207SP0006	6	.2040	3-3/4"	2-1/2"	12	207SP0036	36	.1065	2-1/2"	1-7/16"	12
207SP0007	7	.2010	3-5/8"	2-7/16"	12	207SP0037	37	.1040	2-1/2"	1-7/16"	12
207SP0008	8	.1990	3-5/8"	2-7/16"	12	207SP0038	38	.1015	2-1/2"	1-7/16"	12
207SP0009	9	.1960	3-5/8"	2-7/16"	12	207SP0039	39	.0995	2-3/8"	1-3/8"	12
207SP0010	10	.1935	3-5/8"	2-7/16"	12	207SP0040	40	.0980	2-3/8"	1-3/8"	12
207SP0011	11	.1910	3-1/2"	2-5/16"	12	207SP0041	41	.0960	2-3/8"	1-3/8"	12
207SP0012	12	.1890	3-1/2"	2-5/16"	12	207SP0042	42	.0935	2-1/4"	1-1/4"	12
207SP0013	13	.1850	3-1/2"	2-5/16"	12	207SP0043	43	.0890	2-1/4"	1-1/4"	12
207SP0014	14	.1820	3-3/8"	2-3/16"	12	207SP0044	44	.0860	2-1/8"	1-1/8"	12
207SP0015	15	.1800	3-3/8"	2-3/16"	12	207SP0045	45	.0820	2-1/8"	1-1/8"	12
207SP0016	16	.1770	3-3/8"	2-3/16"	12	207SP0046	46	.0810	2-1/8"	1-1/8"	12
207SP0017	17	.1730	3-3/8"	2-3/16"	12	207SP0047	47	.0785	2"	1"	12
207SP0018	18	.1695	3-1/4"	2-1/8"	12	207SP0048	48	.0760	2"	1"	12
207SP0019	19	.1660	3-1/4"	2-1/8"	12	207SP0049	49	.0730	2"	1"	12
207SP0020	20	.1610	3-1/4"	2-1/8"	12	207SP0050	50	.0700	2"	1"	12
207SP0021	21	.1590	3-1/4"	2-1/8"	12	207SP0051	51	.0670	2"	1"	12
207SP0022	22	.1570	3-1/8"	2"	12	207SP0052	52	.0635	1-7/8"	7/8"	12
207SP0023	23	.1540	3-1/8"	2"	12	207SP0053	53	.0595	1-7/8"	7/8"	12
207SP0024	24	.1520	3-1/8"	2"	12	207SP0054	54	.0550	1-7/8"	7/8"	12
207SP0025	25	.1495	3"	1-7/8"	12	207SP0055	55	.0520	1-7/8"	7/8"	12
207SP0026	26	.1470	3"	1-7/8"	12	207SP0056	56	.0465	1-3/4"	3/4"	12
207SP0027	27	.1440	3"	1-7/8"	12	207SP0057	57	.0430	1-3/4"	3/4"	12
207SP0028	28	.1405	2-7/8"	1-3/4"	12	207SP0058	58	.0420	1-5/8"	11/16"	12
207SP0029	29	.1360	2-7/8"	1-3/4"	12	207SP0059	59	.0410	1-5/8"	11/16"	12
207SP0030	30	.1285	2-3/4"	1-5/8"	12	207SP0060	60	.0400	1-5/8"	11/16"	12

NOTE:
 SIZES 40 → 60
 HAVE NO
 SPLIT POINT.



Jobber Drills - HEAVY DUTY 3/8" Shank - BLACK OXIDE FINISH M2 HSS

Part #	Size	Dec.	OAL	Flute	Qty.	Part #	Size	Dec.	OAL	Flute	Qty.
206R82564	25/64"	.3906	5-1/8"	3-3/4"	6	206R82964	29/64"	.4531	5-5/8"	4-3/16"	6
206R82664	13/32"	.4062	5-1/4"	3-1/8"	6	206R83064	15/32"	.4688	5-3/4"	4-5/16"	6
206R82764	27/64"	.4219	5-3/8"	3-15/16"	6	206R83164	31/64"	.4844	5-7/8"	4-3/8"	6
206R82864	7/16"	.4375	5-1/2"	4-1/16"	6	206R83264	1/2"	.5000	6"	4-1/2"	6

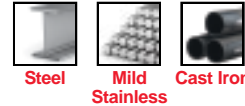

◆ Same as 206SP with 3/8" Shank.

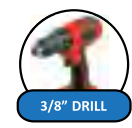

Letter Drills - HEAVY DUTY - BLACK OXIDE FINISH M2 HSS

Part #	Size	Dec.	OAL	Flute	Qty.	Part #	Size	Dec.	OAL	Flute	Qty.
208SP000A	A	.2340	3-7/8"	2-5/8"	12	208SP000N	N	.3020	4-3/8"	3-1/16"	6
208SP000B	B	.2380	4"	2-3/4"	12	208SP000O	O	.3160	4-1/2"	3-3/16"	6
208SP000C	C	.2420	4"	2-3/4"	12	208SP000P	P	.3230	4-5/8"	3-5/16"	6
208SP000D	D	.2460	4"	2-3/4"	12	208SP000Q	Q	.3320	4-3/4"	3-7/16"	6
208SP000E	E	.2500	4"	2-3/4"	12	208SP000R	R	.3390	4-3/4"	3-7/16"	6
208SP000F	F	.2570	4-1/8"	2-7/8"	12	208SP000S	S	.3480	4-7/8"	3-1/2"	6
208SP000G	G	.2610	4-1/8"	2-7/8"	12	208SP000T	T	.3580	4-7/8"	3-1/2"	6
208SP000H	H	.2660	4-1/8"	2-7/8"	12	208SP000U	U	.3680	5"	3-5/8"	6
208SP000I	I	.2720	4-1/8"	2-7/8"	12	208SP000V	V	.3770	5"	3-5/8"	6
208SP000J	J	.2770	4-1/8"	2-7/8"	12	208SP000W	W	.3860	5-1/8"	3-3/4"	6
208SP000K	K	.2810	4-1/4"	2-15/16"	12	208SP000X	X	.3970	5-1/8"	3-3/4"	6
208SP000L	L	.2900	4-1/4"	2-15/16"	6	208SP000Y	Y	.4040	5-1/4"	3-7/8"	6
208SP000M	M	.2950	4-3/8"	3-1/16"	6	208SP000Z	Z	.4130	5-1/4"	3-7/8"	6

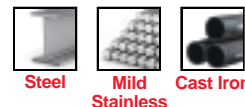

- ◆ Jobber Length
- ◆ 135° Split Point
- ◆ Ground Flute
- ◆ Straight Shank
- ◆ Heavy Duty Web
- ◆ Black Oxide Finish
- ◆ M2 HSS



Metric Drills - General Purpose - BLACK OXIDE FINISH M2 HSS

Part #	Size	Dec.	OAL	Flute	Qty.	Part #	Size	Dec.	OAL	Flute	Qty.
205HS0010	1	.0393	41	18	12	205HS0075	7.5	.2953	111	78	12
205HS0015	1.5	.0591	48	22	12	205HS0080	8	.3150	114	81	12
205HS0020	2	.0787	54	29	12	205HS0085	8.5	.3346	121	87	6
205HS0025	2.5	.0984	60	35	12	205HS0090	9	.3543	124	89	6
205HS0030	3	.1181	70	41	12	205HS0095	9.5	.3740	127	92	6
205HS0035	3.5	.1378	73	45	12	205HS0100	10	.3937	130	95	6
205HS0040	4	.1575	83	54	12	205HS0105	10.5	.4134	137	100	6
205HS0045	4.5	.1772	86	56	12	205HS0110	11	.4331	140	103	6
205HS0050	5	.1969	92	62	12	205HS0115	11.5	.4528	143	106	6
205HS0055	5.5	.2165	95	64	12	205HS0120	12	.4724	150	111	6
205HS0060	6	.2362	102	70	12	205HS0125	12.5	.4921	152	114	6
205HS0065	6.5	.2559	105	73	12	205HS0130	13	.5118	168	122	6
205HS0070	7	.2756	105	73	12						

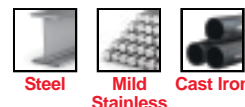

- ◆ Metric Size
- ◆ 118° Point
- ◆ General Purpose
- ◆ Roll Forged
- ◆ Straight Shank
- ◆ Black Oxide Finish
- ◆ M2 HSS



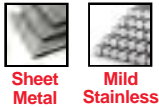
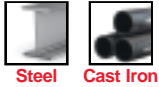

- ◆ Stub Length
- ◆ 135° Split Point
- ◆ Ground Flute
- ◆ Straight Shank
- ◆ Heavy Duty Web
- ◆ Black Oxide Finish
- ◆ M2 HSS



STUB Wire Gauge - HEAVY DUTY

Part #	Size	Dec.	OAL	Flute	Qty.
210SM0001	1	.2280	2-7/16"	1-15/16"	12
210SM0002	2	.2210	2-7/16"	1-15/16"	12
210SM0003	3	.2130	2-3/8"	1-1/4"	12
210SM0004	4	.2090	2-3/8"	1-1/4"	12
210SM0005	5	.2055	2-3/8"	1-1/4"	12
210SM0006	6	.2040	2-3/8"	1-1/4"	12
210SM0007	7	.2010	2-1/4"	1-3/16"	12
210SM0008	8	.1990	2-1/4"	1-3/16"	12
210SM0009	9	.1960	2-1/4"	1-3/16"	12
210SM0010	10	.1935	2-1/4"	1-3/16"	12
210SM0011	11	.1910	2-1/4"	1-3/16"	12
210SM0012	12	.1890	2-1/4"	1-3/16"	12
210SM0013	13	.1850	2-3/16"	1-1/8"	12
210SM0014	14	.1820	2-3/16"	1-1/8"	12
210SM0015	15	.1800	2-3/16"	1-1/8"	12
210SM0016	16	.1770	2-3/16"	1-1/8"	12
210SM0017	17	.1730	2-3/16"	1-1/8"	12
210SM0018	18	.1695	2-1/8"	1-1/16"	12
210SM0019	19	.1660	2-1/8"	1-1/16"	12
210SM0020	20	.1610	2-1/8"	1-1/16"	12
210SM0021	21	.1590	2-1/8"	1-1/16"	12
210SM0022	22	.1570	2-1/8"	1-1/16"	12
210SM0023	23	.1540	2-1/16"	1"	12
210SM0024	24	.1520	2-1/16"	1"	12
210SM0025	25	.1495	2-1/16"	1"	12
210SM0026	26	.1470	2-1/16"	1"	12
210SM0027	27	.1440	2-1/16"	1"	12
210SM0028	28	.1405	1-15/16"	15/16"	12
210SM0029	29	.1360	1-15/16"	15/16"	12
210SM0030	30	.1285	1-15/16"	15/16"	12
210SM0031	31	.1200	1-7/8"	7/8"	12
210SM0032	32	.1160	1-7/8"	7/8"	12
210SM0033	33	.1130	1-7/8"	7/8"	12
210SM0034	34	.1110	1-7/8"	7/8"	12
210SM0035	35	.1100	1-7/8"	7/8"	12
210SM0036	36	.1065	1-13/16"	13/16"	12
210SM0037	37	.1040	1-13/16"	13/16"	12
210SM0038	38	.1015	1-13/16"	13/16"	12
210SM0039	39	.0995	1-13/16"	13/16"	12
210SM0040	40	.0980	1-13/16"	13/16"	12



STUB Fractional - HEAVY DUTY

Part #	Size	Dec.	OAL	Flute	Qty.
209SM0464	1/16"	.0625	1-5/8"	5/8"	12
209SM0564	5/64"	.0781	1-11/16"	11/16"	12
209SM0664	3/32"	.0938	1-3/4"	3/4"	12
209SM0764	7/64"	.1094	1-13/16"	13/16"	12
209SM0864	1/8"	.1250	1-7/8"	7/8"	12
209SM0964	9/64"	.1406	1-15/16"	15/16"	12
209SM1064	5/32"	.1562	2-1/16"	1"	12
209SM1164	11/64"	.1719	2-1/8"	1-1/16"	12
209SM1264	3/16"	.1875	2-3/16"	1-1/8"	12
209SM1364	13/64"	.2031	2-1/4"	1-3/16"	12
209SM1464	7/32"	.2188	2-3/8"	1-1/4"	12
209SM1564	15/64"	.2344	2-7/16"	1-5/16"	12
209SM1664	1/4"	.2500	2-1/2"	1-3/8"	12
209SM1764	17/64"	.2656	2-5/8"	1-7/16"	12
209SM1864	9/32"	.2812	2-11/16"	1-1/2"	12
209SM1964	19/64"	.2969	2-3/4"	1-9/16"	12
209SM2064	5/16"	.3125	2-13/16"	1-5/8"	12
209SM2164	21/64"	.3281	2-15/16"	1-11/16"	6
209SM2264	11/32"	.3438	3"	1-11/16"	6
209SM2364	23/64"	.3594	3-1/16"	1-3/4"	6
209SM2464	3/8"	.3750	3-1/8"	1-13/16"	6
209SM2564	25/64"	.3906	3-1/4"	1-7/8"	6
209SM2664	13/32"	.4062	3-5/16"	1-15/16"	6
209SM2764	27/64"	.4219	3-3/8"	2"	6
209SM2864	7/16"	.4375	3-7/16"	2-1/16"	6
209SM2964	29/64"	.4531	3-9/16"	2-1/8"	6
209SM3064	15/32"	.4688	3-5/8"	2-1/8"	6
209SM3164	31/64"	.4844	3-11/16"	2-3/16"	6
209SM3264	1/2"	.5000	3-3/4"	2-1/4"	6



BLACK Oxide

Silver & Deming - 1/2" Shank - M2 HSS

Part #	Size	Dec.	OAL	Flute	Qty.	Part #	Size	Dec.	OAL	Flute	Qty.
201SD3364	33/64"	.5156	6"	2-3/4"	1	201SD5364	53/64"	.8281	6"	2-3/4"	1
201SD3464	17/32"	.5312	6"	2-3/4"	1	201SD5464	27/32"	.8438	6"	2-3/4"	1
201SD3564	35/64"	.5469	6"	2-3/4"	1	201SD5564	55/64"	.8594	6"	2-3/4"	1
201SD3664	9/16"	.5625	6"	2-3/4"	1	201SD5664	7/8"	.8750	6"	2-3/4"	1
201SD3764	37/64"	.5781	6"	2-3/4"	1	201SD5764	57/64"	.8906	6"	2-3/4"	1
201SD3864	19/32"	.5938	6"	2-3/4"	1	201SD5864	29/32"	.9062	6"	2-3/4"	1
201SD3964	39/64"	.6094	6"	2-3/4"	1	201SD5964	59/64"	.9219	6"	2-3/4"	1
201SD4064	5/8"	.6250	6"	2-3/4"	1	201SD6064	15/16"	.9375	6"	2-3/4"	1
201SD4164	41/64"	.6406	6"	2-3/4"	1	201SD6164	61/64"	.9531	6"	2-3/4"	1
201SD4264	21/32"	.6562	6"	2-3/4"	1	201SD6264	31/32"	.9688	6"	2-3/4"	1
201SD4364	43/64"	.6719	6"	2-3/4"	1	201SD6364	63/64"	.9844	6"	2-3/4"	1
201SD4464	11/16"	.6875	6"	2-3/4"	1	201SD6464	1"	1.0000	6"	2-3/4"	1
201SD4564	45/64"	.7031	6"	2-3/4"	1	201SD8664	1-1/16"	1.0625	6"	2-3/4"	1
201SD4664	23/32"	.7188	6"	2-3/4"	1	201SD7264	1-1/8"	1.1250	6"	2-3/4"	1
201SD4764	47/64"	.7344	6"	2-3/4"	1	201SD7664	1-3/16"	1.1875	6"	2-3/4"	1
201SD4864	3/4"	.7500	6"	2-3/4"	1	201SD8064	1-1/4"	1.2500	6"	2-3/4"	1
201SD4964	49/64"	.7656	6"	2-3/4"	1	201SD8464	1-5/16"	1.3125	6"	2-3/4"	1
201SD5064	25/32"	.7812	6"	2-3/4"	1	201SD8864	1-3/8"	1.3750	6"	2-3/4"	1
201SD5164	51/64"	.7969	6"	2-3/4"	1	201SD9664	1-1/2"	1.5000	6"	2-3/4"	1
201SD5264	13/16"	.8125	6"	2-3/4"	1						

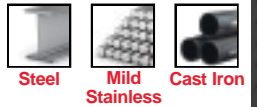

- ◆ 6" Length
- ◆ 118° Point
- ◆ Ground Flute
- ◆ 1/2" Shank
- ◆ Black Oxide Finish
- ◆ M2 HSS



BLACK Oxide

Silver & Deming - 3/8" Shank - M2 HSS

Part #	Size	Dec.	OAL	Flute	Qty.	Part #	Size	Dec.	OAL	Flute	Qty.
201R83364	33/64"	.5156	6"	2-3/4"	1	201R84164	41/64"	.6406	6"	2-3/4"	1
201R83464	17/32"	.5312	6"	2-3/4"	1	201R84264	21/32"	.6562	6"	2-3/4"	1
201R83564	35/64"	.5469	6"	2-3/4"	1	201R84364	43/64"	.6719	6"	2-3/4"	1
201R83664	9/16"	.5625	6"	2-3/4"	1	201R84464	11/16"	.6875	6"	2-3/4"	1
201R83764	37/64"	.5781	6"	2-3/4"	1	201R84564	45/64"	.7031	6"	2-3/4"	1
201R83864	19/32"	.5938	6"	2-3/4"	1	201R84664	23/32"	.7188	6"	2-3/4"	1
201R83964	39/64"	.6094	6"	2-3/4"	1	201R84764	47/64"	.7344	6"	2-3/4"	1
201R84064	5/8"	.6250	6"	2-3/4"	1	201R84864	3/4"	.7500	6"	2-3/4"	1

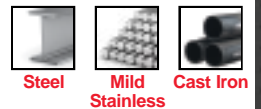

- ◆ 6" Length
- ◆ 118° Point
- ◆ Ground Flute
- ◆ 3/8" Shank
- ◆ Black Oxide Finish
- ◆ M2 HSS





INTERNATIONAL TOOL MANUFACTURING

150 Express St. Plainview, NY 11803

(516) 738-0388 • (800) 247-5696

Fax (516) 279-1106

100% LAB TESTED

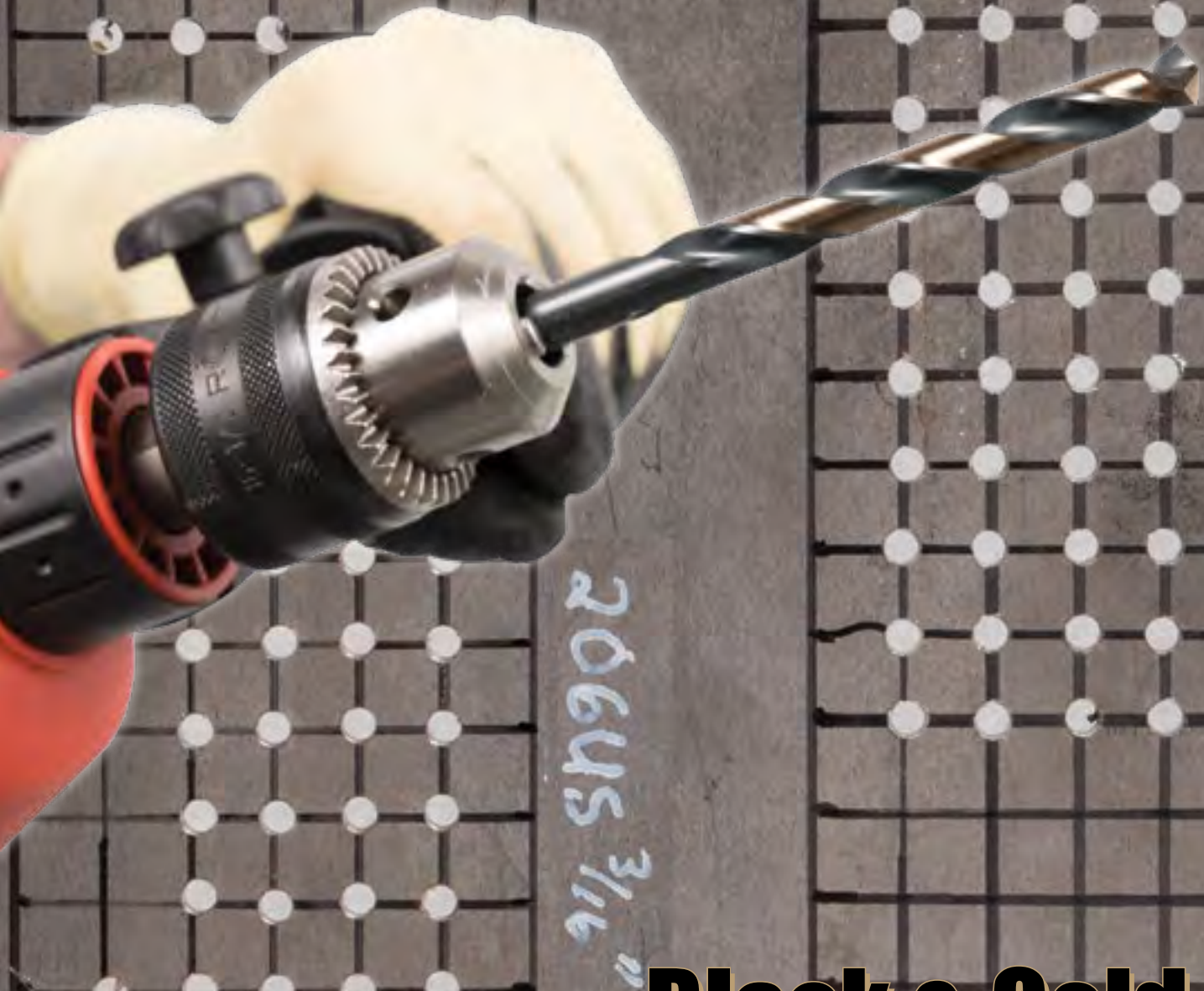

Black & Gold

The Most Recognizable Finish Anywhere.



Black & Gold Jobber Drills - HEAVY DUTY - M2 HSS

Part #	Size	Dec.	OAL	Flute	Qty.	Part #	Size	Dec.	OAL	Flute	Qty.
206US0464	1/16"	.0625	1-7/8"	7/8"	12	206US1964	19/64"	.2969	4-3/8"	3-1/16"	12
206US0564	5/64"	.0781	2"	1"	12	206US2064	5/16"	.3125	4-1/2"	3-3/16"	12
206US0664	3/32"	.0938	2-1/4"	1-1/4"	12	206US2164	21/64"	.3281	4-5/8"	3-5/16"	6
206US0764	7/64"	.1094	2-5/8"	1-1/2"	12	206US2264	11/32"	.3438	4-3/4"	3-7/16"	6
206US0864	1/8"	.1250	2-3/4"	1-5/8"	12	206US2364	23/64"	.3594	4-7/8"	3-1/2"	6
206US0964	9/64"	.1406	2-7/8"	1-3/4"	12	206US2464	3/8"	.3750	5"	3-5/8"	6
206US1064	5/32"	.1562	3-1/8"	2"	12	206US2564	25/64"	.3906	5-1/8"	3-3/4"	6
206US1164	11/64"	.1719	3-1/4"	2-1/8"	12	206US2664	13/32"	.4062	5-1/4"	3-7/8"	6
206US1264	3/16"	.1875	3-1/2"	2-5/16"	12	206US2764	27/64"	.4219	5-3/8"	3-15/16"	6
206US1364	13/64"	.2031	3-5/8"	2-7/16"	12	206US2864	7/16"	.4375	5-1/2"	4-1/16"	6
206US1464	7/32"	.2188	3-3/4"	2-1/2"	12	206US2964	29/64"	.4531	5-5/8"	4-3/16"	6
206US1564	15/64"	.2344	3-7/8"	2-5/8"	12	206US3064	15/32"	.4688	5-3/4"	4-5/16"	6
206US1664	1/4"	.2500	4"	2-3/4"	12	206US3164	31/64"	.4844	5-7/8"	4-3/8"	6
206US1764	17/64"	.2656	4-1/8"	2-7/8"	12	206US3264	1/2"	.5000	6"	4-1/2"	6
206US1864	9/32"	.2812	4-1/4"	2-15/16"	12						

Black & Gold



- ◆ Jobber Length
- ◆ 135° Split Point
- ◆ Ground Flute
- ◆ Straight Shank
- ◆ Heavy Duty Web
- ◆ Black & Gold Finish
- ◆ M2 HSS



Black & Gold Wire Gauge Drills - HEAVY DUTY - M2 HSS

Part #	Size	Dec.	OAL	Flute	Qty.	Part #	Size	Dec.	OAL	Flute	Qty.
207US-01	1	.2280	3-7/8"	2-5/8"	12	207US-31	31	.1200	2-3/4"	1-5/8"	12
207US-02	2	.2210	3-7/8"	2-5/8"	12	207US-32	32	.1160	2-3/4"	1-5/8"	12
207US-03	3	.2130	3-3/4"	2-1/2"	12	207US-33	33	.1130	2-5/8"	1-1/2"	12
207US-04	4	.2090	3-3/4"	2-1/2"	12	207US-34	34	.1110	2-5/8"	1-1/2"	12
207US-05	5	.2055	3-3/4"	2-1/2"	12	207US-35	35	.1100	2-5/8"	1-1/2"	12
207US-06	6	.2040	3-3/4"	2-1/2"	12	207US-36	36	.1065	2-1/2"	1-7/16"	12
207US-07	7	.2010	3-5/8"	2-7/16"	12	207US-37	37	.1040	2-1/2"	1-7/16"	12
207US-08	8	.1990	3-5/8"	2-7/16"	12	207US-38	38	.1015	2-1/2"	1-7/16"	12
207US-09	9	.1960	3-5/8"	2-7/16"	12	207US-39	39	.0995	2-3/8"	1-3/8"	12
207US-10	10	.1935	3-5/8"	2-7/16"	12	207US-40	40	.0980	2-3/8"	1-3/8"	12
207US-11	11	.1910	3-1/2"	2-5/16"	12	207US-41	41	.0960	2-3/8"	1-3/8"	12
207US-12	12	.1890	3-1/2"	2-5/16"	12	207US-42	42	.0935	2-1/4"	1-1/4"	12
207US-13	13	.1850	3-1/2"	2-5/16"	12	207US-43	43	.0890	2-1/4"	1-1/4"	12
207US-14	14	.1820	3-3/8"	2-3/16"	12	207US-44	44	.0860	2-1/8"	1-1/8"	12
207US-15	15	.1800	3-3/8"	2-3/16"	12	207US-45	45	.0820	2-1/8"	1-1/8"	12
207US-16	16	.1770	3-3/8"	2-3/16"	12	207US-46	46	.0810	2-1/8"	1-1/8"	12
207US-17	17	.1730	3-3/8"	2-3/16"	12	207US-47	47	.0785	2"	1"	12
207US-18	18	.1695	3-1/4"	2-1/8"	12	207US-48	48	.0760	2"	1"	12
207US-19	19	.1660	3-1/4"	2-1/8"	12	207US-49	49	.0730	2"	1"	12
207US-20	20	.1610	3-1/4"	2-1/8"	12	207US-50	50	.0700	2"	1"	12
207US-21	21	.1590	3-1/4"	2-1/8"	12	207US-51	51	.0670	2"	1"	12
207US-22	22	.1570	3-1/8"	2"	12	207US-52	52	.0635	1-7/8"	7/8"	12
207US-23	23	.1540	3-1/8"	2"	12	207US-53	53	.0595	1-7/8"	7/8"	12
207US-24	24	.1520	3-1/8"	2"	12	207US-54	54	.0550	1-7/8"	7/8"	12
207US-25	25	.1495	3"	1-7/8"	12	207US-55	55	.0520	1-7/8"	7/8"	12
207US-26	26	.1470	3"	1-7/8"	12	207US-56	56	.0465	1-3/4"	3/4"	12
207US-27	27	.1440	3"	1-7/8"	12	207US-57	57	.0430	1-3/4"	3/4"	12
207US-28	28	.1405	2-7/8"	1-3/4"	12	207US-58	58	.0420	1-5/8"	11/16"	12
207US-29	29	.1360	2-7/8"	1-3/4"	12	207US-59	59	.0410	1-5/8"	11/16"	12
207US-30	30	.1285	2-3/4"	1-5/8"	12	207US-60	60	.0400	1-5/8"	11/16"	12



Black & Gold



- ◆ Wire Gauge
- ◆ 135° Split Point
- ◆ Ground Flute
- ◆ Straight Shank
- ◆ Heavy Duty Web
- ◆ Black & Gold Finish
- ◆ M2 HSS



NOTE:
SIZES 40 → 60
HAVE NO
SPLIT POINT.



INTERNATIONAL TOOL MANUFACTURING
 150 Express St. Plainview, NY 11803
 (516) 738-0388 • (800) 247-5696
 Fax (516) 279-1106



Black & Gold Black & Gold Jobber Drills - HEAVY DUTY 3/8" Shank - M2 HSS



Part #	Size	Dec.	OAL	Flute	Qty.	Part #	Size	Dec.	OAL	Flute	Qty.
206U82564	25/64"	.3906	5-1/8"	3-3/4"	6	206U82964	29/64"	.4531	5-5/8"	4-3/16"	6
206U82664	13/32"	.4062	5-1/4"	3-1/8"	6	206U83064	15/32"	.4688	5-3/4"	4-5/16"	6
206U82764	27/64"	.4219	5 -3/8"	3-15/16"	6	206U83164	31/64"	.4844	5-7/8"	4-3/8"	6
206U82864	7/16"	.4375	5-1/2"	4-1/16"	6	206U83264	1/2"	.5000	6"	4-1/2"	6

- ◆ Jobber Length
- ◆ 3/8" Shank
- ◆ 135° Split Point
- ◆ Ground Flute
- ◆ Straight Shank
- ◆ Heavy Duty Web
- ◆ M2 HSS



Black & Gold Black & Gold Mechanics Length Drills - HEAVY DUTY - M2 HSS



Part #	Size	Dec.	OAL	Flute	Qty.	Part #	Size	Dec.	OAL	Flute	Qty.
208MC0464	1/16"	.0625	1 7/8"	7/8"	12	208MC1964	19/64"	.2969	3-7/8"	2-3/8"	12
208MC0564	5/64"	.0781	2"	1"	12	208MC2064	5/16"	.3125	4"	2-1/2"	12
208MC0664	3/32"	.0938	2-1/4"	1-1/4"	12	208MC2164	21/64"	.3281	4-1/16"	2-9/16"	6
208MC0764	7/64"	.1094	2-3/8"	1-5/16"	12	208MC2264	11/32"	.3438	4-1/8"	2-5/8"	6
208MC0864	1/8"	.1250	2-1/2"	1-7/16"	12	208MC2364	23/64"	.3594	4-3/16"	2-11/16"	6
208MC0964	9/64"	.1406	2-5/8"	1-9/16"	12	208MC2464	3/8"	.3750	4-1/4"	2-11/16"	6
208MC1064	5/32"	.1562	2-3/4"	1-11/16"	12	208MC2564	25/64"	.3906	4-5/16"	2-3/4"	6
208MC1164	11/64"	.1719	2-7/8"	1-13/16"	12	208MC2664	13/32"	.4062	4-3/8"	2-13/16"	6
208MC1264	3/16"	.1875	3"	1-7/8"	12	208MC2764	27/64"	.4219	4-7/16"	2-7/8"	6
208MC1364	13/64"	.2031	3-1/8"	1-15/16"	12	208MC2864	7/16"	.4375	4-1/2"	2-15/16"	6
208MC1464	7/32"	.2188	3-1/4"	2"	12	208MC2964	29/64"	.4531	4-5/8"	3"	6
208MC1564	15/64"	.2344	3-3/8"	2"	12	208MC3064	15/32"	.4688	4-3/4"	3-1/8"	6
208MC1664	1/4"	.2500	3-1/2"	2"	12	208MC3164	31/64"	.4844	4-7/8"	3-1/4"	6
208MC1764	17/64"	.2656	3-5/8"	2-1/8"	12	208MC3264	1/2"	.5000	5"	3-3/8"	6
208MC1864	9/32"	.2812	3-3/4"	2-1/4"	12						

- ◆ Mechanics Length
- ◆ 135° Split Point
- ◆ 3-Flat Shank (3/16" → 1/2")
- ◆ Black & Gold Finish for Strength & Rigidity
- ◆ M2 HSS





Black & Gold Letter Drills - HEAVY DUTY - M2 HSS

Part #	Size	Dec.	OAL	Flute	Qty.	Part #	Size	Dec.	OAL	Flute	Qty.
208US-A	A	.234	3-7/8"	2-5/8"	12	208US-N	N	.302	4-3/8"	3-1/16"	6
208US-B	B	.238	4"	2-3/4"	12	208US-O	O	.316	4-1/2"	3-3/16"	6
208US-C	C	.242	4"	2-3/4"	12	208US-P	P	.323	4-5/8"	3-5/16"	6
208US-D	D	.246	4"	2-3/4"	12	208US-Q	Q	.332	4-3/4"	3-7/16"	6
208US-E	E	.250	4"	2-3/4"	12	208US-R	R	.339	4-3/4"	3-7/16"	6
208US-F	F	.257	4-1/8"	2-7/8"	12	208US-S	S	.348	4-7/8"	3-1/2"	6
208US-G	G	.261	4-1/8"	2-7/8"	12	208US-T	T	.358	4-7/8"	3-1/2"	6
208US-H	H	.266	4-1/8"	2-7/8"	12	208US-U	U	.368	5"	3-5/8"	6
208US-I	I	.272	4-1/8"	2-7/8"	12	208US-V	V	.377	5"	3-5/8"	6
208US-J	J	.277	4-1/8"	2-7/8"	12	208US-W	W	.386	5-1/8"	3-3/4"	6
208US-K	K	.281	4-1/4"	2-15/16"	12	208US-X	X	.397	5-1/8"	3-3/4"	6
208US-L	L	.290	4-1/4"	2-15/16"	6	208US-Y	Y	.404	5-1/4"	3-7/8"	6
208US-M	M	.295	4-3/8"	3-1/16"	6	208US-Z	Z	.413	5-1/4"	3-7/8"	6

Black & Gold

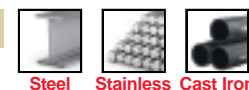

- ◆ Jobber Length
- ◆ 135° Split Point
- ◆ Ground Flute
- ◆ Straight Shank
- ◆ Heavy Duty Web
- ◆ Black & Gold Finish
- ◆ M2 HSS



Black & Gold Silver & Deming - 1/2" Shank - M2 HSS

Part #	Size	Dec.	OAL	Flute	Qty.	Part #	Size	Dec.	OAL	Flute	Qty.
201US3364	33/64"	.5156	6"	2-3/4"	1	201US5164	51/64"	.7969	6"	2-3/4"	1
201US3464	17/32"	.5312	6"	2-3/4"	1	201US5264	13/16"	.8125	6"	2-3/4"	1
201US3564	35/64"	.5469	6"	2-3/4"	1	201US5364	53/64"	.8281	6"	2-3/4"	1
201US3664	9/16"	.5625	6"	2-3/4"	1	201US5464	27/32"	.8438	6"	2-3/4"	1
201US3764	37/64"	.5781	6"	2-3/4"	1	201US5564	55/64"	.8594	6"	2-3/4"	1
201US3864	19/32"	.5938	6"	2-3/4"	1	201US5664	7/8"	.8750	6"	2-3/4"	1
201US3964	39/64"	.6094	6"	2-3/4"	1	201US5764	57/64"	.8906	6"	2-3/4"	1
201US4064	5/8"	.6250	6"	2-3/4"	1	201US5864	29/32"	.9062	6"	2-3/4"	1
201US4164	41/64"	.6406	6"	2-3/4"	1	201US5964	59/64"	.9219	6"	2-3/4"	1
201US4264	21/32"	.6562	6"	2-3/4"	1	201US6064	15/16"	.9375	6"	2-3/4"	1
201US4364	43/64"	.6719	6"	2-3/4"	1	201US6164	61/64"	.9531	6"	2-3/4"	1
201US4464	11/16"	.6875	6"	2-3/4"	1	201US6264	31/32"	.9688	6"	2-3/4"	1
201US4564	45/64"	.7031	6"	2-3/4"	1	201US6364	63/64"	.9844	6"	2-3/4"	1
201US4664	23/32"	.7188	6"	2-3/4"	1	201US6464	1"	1.0000	6"	2-3/4"	1
201US4764	47/64"	.7344	6"	2-3/4"	1	201US6864	1-1/16"	1.0625	6"	2-3/4"	1
201US4864	3/4"	.7500	6"	2-3/4"	1	201US7264	1-1/8"	1.1250	6"	2-3/4"	1
201US4964	49/64"	.7656	6"	2-3/4"	1	201US7664	1-3/16"	1.1875	6"	2-3/4"	1
201US5064	25/32"	.7812	6"	2-3/4"	1	201US8064	1-1/4"	1.2500	6"	2-3/4"	1

Black & Gold

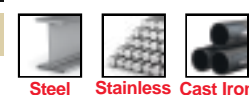

- ◆ 6" Length
- ◆ 118° Split Point
- ◆ Ground Flute
- ◆ 3-Flat Round 1/2" Shank
- ◆ Heavy Duty Web
- ◆ Black & Gold Finish
- ◆ M2 HSS





3-Flat, No-Slip Shank
 (3/16" → 1/2")

Made in U.S.A.

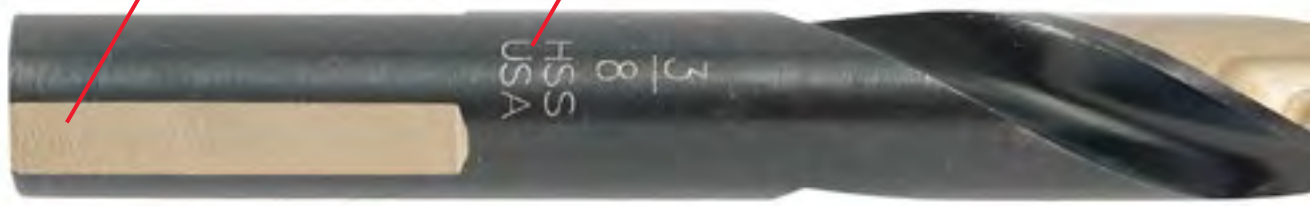

Black & Gold MRO Black and Gold Jobber Drills - SUPER HEAVY DUTY - M2 HSS



- ◆ Jobber Length
- ◆ 135° Split Point
- ◆ Ground Flute
- ◆ 3-Flat Shank (3/16" → 1/2")
- ◆ 3-Flat Shank On All Letter Drills
- ◆ Heavy Duty Web for Strength & Rigidity
- ◆ Black & Gold Finish
- ◆ M2 HSS

Part #	Size	Dec.	OAL	Flute	Qty.	Part #	Size	Dec.	OAL	Flute	Qty.
MRO-0464	1/16"	.0625	1-7/8"	7/8"	12	MRO-1964	19/64"	.2969	4-3/8"	3-1/16"	12
MRO-0564	5/64"	.0781	2"	1"	12	MRO-2064	5/16"	.3125	4-1/2"	3-3/16"	12
MRO-0664	3/32"	.0938	2-1/4"	1-1/4"	12	MRO-2164	21/64"	.3281	4-5/8"	3-5/16"	6
MRO-0764	7/64"	.1094	2-5/8"	1-1/2"	12	MRO-2264	11/32"	.3438	4-3/4"	3-7/16"	6
MRO-0864	1/8"	.1250	2-3/4"	1-5/8"	12	MRO-2364	23/64"	.3594	4-7/8"	3-1/2"	6
MRO-0964	9/64"	.1406	2-7/8"	1-3/4"	12	MRO-2464	3/8"	.3750	5"	3-5/8"	6
MRO-1064	5/32"	.1562	3-1/8"	2"	12	MRO-2564	25/64"	.3906	5-1/8"	3-3/4"	6
MRO-1164	11/64"	.1719	3-1/4"	2-1/8"	12	MRO-2664	13/32"	.4062	5-1/4"	3-7/8"	6
MRO-1264	3/16"	.1875	3-1/2"	2-5/16"	12	MRO-2764	27/64"	.4219	5-3/8"	3-15/16"	6
MRO-1364	13/64"	.2031	3-5/8"	2-7/16"	12	MRO-2864	7/16"	.4375	5-1/2"	4-1/16"	6
MRO-1464	7/32"	.2188	3-3/4"	2-1/2"	12	MRO-2964	29/64"	.4531	5-5/8"	4-3/16"	6
MRO-1564	15/64"	.2344	3-7/8"	2-5/8"	12	MRO-3064	15/32"	.4688	5-3/4"	4-5/16"	6
MRO-1664	1/4"	.2500	4"	2-3/4"	12	MRO-3164	31/64"	.4844	5-7/8"	4-3/8"	6
MRO-1764	17/64"	.2656	4-1/8"	2-7/8"	12	MRO-3264	1/2"	.5000	6"	4-1/2"	6
MRO-1864	9/32"	.2812	4-1/4"	2-15/16"	12						



Made In



MRO Black & Gold Letter Drills - SUPER HEAVY DUTY - M2 HSS

Part #	Size	Dec.	OAL	Flute	Qty.	Part #	Size	Dec.	OAL	Flute	Qty.
MRO-A	A	.234	3-7/8"	2-5/8"	12	MRO-N	N	.302	4-3/8"	3-1/16"	6
MRO-B	B	.238	4"	2-3/4"	12	MRO-O	O	.316	4-1/2"	3-3/16"	6
MRO-C	C	.242	4"	2-3/4"	12	MRO-P	P	.323	4-5/8"	3-5/16"	6
MRO-D	D	.246	4"	2-3/4"	12	MRO-Q	Q	.332	4-3/4"	3-7/16"	6
MRO-E	E	.250	4"	2-3/4"	12	MRO-R	R	.339	4-3/4"	3-7/16"	6
MRO-F	F	.257	4-1/8"	2-7/8"	12	MRO-S	S	.348	4-7/8"	3-1/2"	6
MRO-G	G	.261	4-1/8"	2-7/8"	12	MRO-T	T	.358	4-7/8"	3-1/2"	6
MRO-H	H	.266	4-1/8"	2-7/8"	12	MRO-U	U	.368	5"	3-5/8"	6
MRO-I	I	.272	4-1/8"	2-7/8"	12	MRO-V	V	.377	5"	3-5/8"	6
MRO-J	J	.277	4-1/8"	2-7/8"	12	MRO-W	W	.386	5-1/8"	3-3/4"	6
MRO-K	K	.281	4-1/4"	2-15/16"	12	MRO-X	X	.397	5-1/8"	3-3/4"	6
MRO-L	L	.290	4-1/4"	2-15/16"	6	MRO-Y	Y	.404	5-1/4"	3-7/8"	6
MRO-M	M	.295	4-3/8"	3-1/16"	6	MRO-Z	Z	.413	5-1/4"	3-7/8"	6



MRO Black & Gold Wire Gauge Drills - SUPER HEAVY DUTY - M2 HSS

Black & Gold

Part #	Size	Dec.	OAL	Flute	Qty.	Part #	Size	Dec.	OAL	Flute	Qty.
MRO-01	1	.2280	3-7/8"	2-5/8"	12	MRO-21	21	.1590	3-1/4"	2-1/8"	12
MRO-02	2	.2210	3-7/8"	2-5/8"	12	MRO-22	22	.1570	3-1/8"	2"	12
MRO-03	3	.2130	3-3/4"	2-1/2"	12	MRO-23	23	.1540	3-1/8"	2"	12
MRO-04	4	.2090	3-3/4"	2-1/2"	12	MRO-24	24	.1520	3-1/8"	2"	12
MRO-05	5	.2055	3-3/4"	2-1/2"	12	MRO-25	25	.1495	3"	1-7/8"	12
MRO-06	6	.2040	3-3/4"	2-1/2"	12	MRO-26	26	.1470	3"	1-7/8"	12
MRO-07	7	.2010	3-5/8"	2-7/16"	12	MRO-27	27	.1440	3"	1-7/8"	12
MRO-08	8	.1990	3-5/8"	2-7/16"	12	MRO-28	28	.1405	2-7/8"	1-3/4"	12
MRO-09	9	.1960	3-5/8"	2-7/16"	12	MRO-29	29	.1360	2-7/8"	1-3/4"	12
MRO-10	10	.1935	3-5/8"	2-7/16"	12	MRO-30	30	.1285	2-3/4"	1-5/8"	12
MRO-11	11	.1910	3-1/2"	2-5/16"	12	MRO-31	31	.1200	2-3/4"	1-5/8"	12
MRO-12	12	.1890	3-1/2"	2-5/16"	12	MRO-32	32	.1160	2-3/4"	1-5/8"	12
MRO-13	13	.1850	3-1/2"	2-5/16"	12	MRO-33	33	.1130	2-5/8"	1-1/2"	12
MRO-14	14	.1820	3-3/8"	2-3/16"	12	MRO-34	34	.1110	2-5/8"	1-1/2"	12
MRO-15	15	.1800	3-3/8"	2-3/16"	12	MRO-35	35	.1100	2-5/8"	1-1/2"	12
MRO-16	16	.1770	3-3/8"	2-3/16"	12	MRO-36	36	.1065	2-1/2"	1-7/16"	12
MRO-17	17	.1730	3-3/8"	2-3/16"	12	MRO-37	37	.1040	2-1/2"	1-7/16"	12
MRO-18	18	.1695	3-1/4"	2-1/8"	12	MRO-38	38	.1015	2-1/2"	1-7/16"	12
MRO-19	19	.1660	3-1/4"	2-1/8"	12	MRO-39	39	.0995	2-3/8"	1-3/8"	12
MRO-20	20	.1610	3-1/4"	2-1/8"	12	MRO-40	40	.0980	2-3/8"	1-3/8"	12



- ◆ 135° Split Point
- ◆ Ground Flute
- ◆ 3-Flat Shank on #1-12
- ◆ Heavy Duty Web for Strength & Rigidity
- ◆ Black & Gold Finish
- ◆ M2 HSS



**Sizes 41-60 are available upon request.



NOTE:
SIZES 40 → 60
HAVE NO
SPLIT POINT.



MRO
MADE IN USA



COBALT

Cobalt Jobber Drills - HEAVY DUTY - M35 COBALT



Table with 12 columns: Part #, Size, Dec., OAL, Flute, Qty. (repeated for two columns of data)

- Jobber Length
135° Split Point
Ground Flute
Straight Shank
Heavy Duty Web
Gold Finish
M35 Cobalt



COBALT

Cobalt Wire Gauge Drills - HEAVY DUTY - M35 COBALT



Table with 12 columns: Part #, Size, Dec., OAL, Flute, Qty. (repeated for two columns of data)

- Wire Gauge
135° Split Point
Ground Flute
Straight Shank
Heavy Duty Web
Gold Finish
M35 Cobalt



NOTE:
SIZES 40 -> 60
HAVE NO
SPLIT POINT.



COBALT

Cobalt Jobber Drills - 3/8" Shank - M35 COBALT

Part #	Size	Dec.	OAL	Flute	Qty.	Part #	Size	Dec.	OAL	Flute	Qty.
219R82564	25/64"	.3906	5-1/8"	3-3/4"	6	219R82964	29/64"	.4531	5-5/8"	4-3/16"	6
219R82664	13/32"	.4062	5-1/4"	3-1/8"	6	219R83064	15/32"	.4688	5-3/4"	4-5/16"	6
219R82764	27/64"	.4219	5-3/8"	3-15/16"	6	219R83164	31/64"	.4844	5-7/8"	4-3/8"	6
219R82864	7/16"	.4375	5-1/2"	4-1/16"	6	219R83264	1/2"	.5000	6"	4-1/2"	6



◆ Same as 219CO with 3/8" Shank.

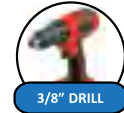

COBALT

Cobalt Stub Fractional - M35 COBALT

Part #	Size	Dec.	OAL	Flute	Qty.	Part #	Size	Dec.	OAL	Flute	Qty.
CTS-0464	1/16"	.0625	1-5/8"	5/8"	12	CTS-1964	19/64"	.2969	2-3/4"	1-9/16"	12
CTS-0564	5/64"	.0781	1-11/16"	11/16"	12	CTS-2064	5/16"	.3125	2-13/16"	1-5/8"	12
CTS-0664	3/32"	.0938	1-3/4"	3/4"	12	CTS-2164	21/64"	.3281	2-15/16"	1-11/16"	6
CTS-0764	7/64"	.1094	1-13/16"	13/16"	12	CTS-2264	11/32"	.3438	3"	1-11/16"	6
CTS-0864	1/8"	.1250	1-7/8"	7/8"	12	CTS-2364	23/64"	.3594	3-1/16"	1-3/4"	6
CTS-0964	9/64"	.1406	1-15/16"	15/16"	12	CTS-2464	3/8"	.3750	3-1/8"	1-13/16"	6
CTS-1064	5/32"	.1562	2-1/16"	1"	12	CTS-2564	25/64"	.3906	3-1/4"	1-7/8"	6
CTS-1164	11/64"	.1719	2-1/8"	1-1/16"	12	CTS-2664	13/32"	.4062	3-5/16"	1-15/16"	6
CTS-1264	3/16"	.1875	2-3/16"	1-1/8"	12	CTS-2764	27/64"	.4219	3-3/8"	2"	6
CTS-1364	13/64"	.2031	2-1/4"	1-3/16"	12	CTS-2864	7/16"	.4375	3-7/16"	2-1/16"	6
CTS-1464	7/32"	.2188	2-3/8"	1-1/4"	12	CTS-2964	29/64"	.4531	3-9/16"	2-1/8"	6
CTS-1564	15/64"	.2344	2-7/16"	1-5/16"	12	CTS-3064	15/32"	.4688	3-5/8"	2-1/8"	6
CTS-1664	1/4"	.2500	2-1/2"	1-3/8"	12	CTS-3164	31/64"	.4844	3-11/16"	2-3/16"	6
CTS-1764	17/64"	.2656	2-5/8"	1-7/16"	12	CTS-3264	1/2"	.5000	3-3/4"	2-1/4"	6
CTS-1864	9/32"	.2812	2-11/16"	1-1/2"	12						



- ◆ Stub Length
- ◆ 135° Split Point
- ◆ Ground Flute
- ◆ Straight Shank
- ◆ Heavy Duty Web
- ◆ Gold Finish
- ◆ M35 Cobalt



COBALT

Cobalt Silver & Deming - 1/2" Shank - M35 COBALT

Part #	Size	Dec.	OAL	Flute	Qty.	Part #	Size	Dec.	OAL	Flute	Qty.
201CO3464	17/32"	.5312	6	2-3/4"	1	201CO5864	29/32"	.9062	6	2-3/4"	1
201CO3664	9/16"	.5625	6	2-3/4"	1	201CO6064	15/16"	.9375	6	2-3/4"	1
201CO3864	19/32"	.5938	6	2-3/4"	1	201CO6264	31/32"	.9688	6	2-3/4"	1
201CO4064	5/8"	.6250	6	2-3/4"	1	201CO6464	1"	1.0000	6	2-3/4"	1
201CO4264	21/32"	.6562	6	2-3/4"	1	201CO6864	1-1/16"	1.0625	6	2-3/4"	1
201CO4464	11/16"	.6875	6	2-3/4"	1	201CO7264	1-1/8"	1.1250	6	2-3/4"	1
201CO4664	23/32"	.7188	6	2-3/4"	1	201CO7664	1-3/16"	1.1875	6	2-3/4"	1
201CO4864	3/4"	.7500	6	2-3/4"	1	201CO8064	1-1/4"	1.2500	6	2-3/4"	1
201CO5064	25/32"	.7812	6	2-3/4"	1	201CO8464	1-5/16"	1.3125	6	2-3/4"	1
201CO5264	13/16"	.8125	6	2-3/4"	1	201CO8864	1-3/8"	1.3750	6	2-3/4"	1
201CO5464	27/32"	.8438	6	2-3/4"	1	201CO9664	1-1/2"	1.5000	6	2-3/4"	1
201CO5664	7/8"	.8750	6	2-3/4"	1						



- ◆ 6" Length
- ◆ 118° Split Point
- ◆ Ground Flute
- ◆ 3-Flat Round 1/2" Shank
- ◆ Gold Finish
- ◆ M35 Cobalt





Titanium Jobber Drills - (TiN) Coating - M2 HSS

Part #	Size	Dec.	OAL	Flute	Qty.	Part #	Size	Dec.	OAL	Flute	Qty.
255SP0464	1/16"	.0625	1-7/8"	7/8"	12	255SP1964	19/64"	.2969	4-3/8"	3-1/16"	12
255SP0564	5/64"	.0781	2"	1"	12	255SP2064	5/16"	.3125	4-1/2"	3-3/16"	12
255SP0664	3/32"	.0938	2-1/4"	1-1/4"	12	255SP2164	21/64"	.3281	4-5/8"	3-5/16"	6
255SP0764	7/64"	.1094	2-5/8"	1-1/2"	12	255SP2264	11/32"	.3438	4-3/4"	3-7/16"	6
255SP0864	1/8"	.1250	2-3/4"	1-5/8"	12	255SP2364	23/64"	.3594	4-7/8"	3-1/2"	6
255SP0964	9/64"	.1406	2-7/8"	1-3/4"	12	255SP2464	3/8"	.3750	5"	3-5/8"	6
255SP1064	5/32"	.1562	3-1/8"	2"	12	255SP2564	25/64"	.3906	5-1/8"	3-3/4"	6
255SP1164	11/64"	.1719	3-1/4"	2-1/8"	12	255SP2664	13/32"	.4062	5-1/4"	3-7/8"	6
255SP1264	3/16"	.1875	3-1/2"	2-5/16"	12	255SP2764	27/64"	.4219	5-3/8"	3-15/16"	6
255SP1364	13/64"	.2031	3-5/8"	2-7/16"	12	255SP2864	7/16"	.4375	5-1/2"	4-1/16"	6
255SP1464	7/32"	.2188	3-3/4"	2-1/2"	12	255SP2964	29/64"	.4531	5-5/8"	4-3/16"	6
255SP1564	15/64"	.2344	3-7/8"	2-5/8"	12	255SP3064	15/32"	.4688	5-3/4"	4-5/16"	6
255SP1664	1/4"	.2500	4"	2-3/4"	12	255SP3164	31/64"	.4844	5-7/8"	4-3/8"	6
255SP1764	17/64"	.2656	4-1/8"	2-7/8"	12	255SP3264	1/2"	.5000	6"	4-1/2"	6
255SP1864	9/32"	.2812	4-1/4"	2-15/16"	12						



- ◆ Jobber Length
- ◆ 135° Split Point
- ◆ Ground Flute
- ◆ Straight Shank
- ◆ Heavy Duty Web
- ◆ TiN Coating
- ◆ M2 HSS



1/4" Hex Titanium Jobber Drills - (TiN) Coating - M2 HSS

Part #	Size	Dec.	OAL	Flute	Qty.	Part #	Size	Dec.	OAL	Flute	Qty.
255HEX0464	1/16"	.0625	1-7/8"	7/8"	12	255HEX1664	1/4"	.2500	4"	2-3/4"	12
255HEX0664	3/32"	.0938	2-1/4"	1-1/4"	12	255HEX1864	9/32"	.2812	4-1/4"	2-15/16"	12
255HEX0864	1/8"	.1250	2-3/4"	1-5/8"	12	255HEX2064	5/16"	.3125	4-1/2"	3-3/16"	12
255HEX1064	5/32"	.1562	3-1/8"	2"	12	255HEX2464	3/8"	.3750	5"	3-5/8"	6
255HEX1264	3/16"	.1875	3-1/2"	2-5/16"	12	255HEX2864	7/16"	.4375	5-1/2"	4-1/16"	6
255HEX1464	7/32"	.2188	3-3/4"	2-1/2"	12	255HEX3264	1/2"	.5000	6"	4-1/2"	6



- ◆ 1/4" Hex Impact Shank
- ◆ Jobber Length
- ◆ 135° Split Point
- ◆ 1 Pc. Construction >3/16"
- ◆ Ground Flute
- ◆ Heavy Duty Web
- ◆ TiN Coating
- ◆ M2 HSS



1/4" Hex Titanium Jobber Drills - (TiN) Coating - M2 HSS

Part #	Size	Dec.	OAL	Flute	Qty.	Part #	Size	Dec.	OAL	Flute	Qty.
255H04	1/16"	.0625	1-7/8"	7/8"	1	255H16	1/4"	.2500	4"	2-3/4"	1
255H06	3/32"	.0938	2-1/4"	1-1/4"	1	255H18	9/32"	.2812	4-1/4"	2-15/16"	1
255H08	1/8"	.1250	2-3/4"	1-5/8"	1	255H20	5/16"	.3125	4-1/2"	3-3/16"	1
255H10	5/32"	.1562	3-1/8"	2"	1	255H24	3/8"	.3750	5"	3-5/8"	1
255H12	3/16"	.1875	3-1/2"	2-5/16"	1	255H28	7/16"	.4375	5-1/2"	4-1/16"	1
255H14	7/32"	.2188	3-3/4"	2-1/2"	1	255H32	1/2"	.5000	6"	4-1/2"	1



Rack P. 72



Parabolic Jobber Drills - SUPER HEAVY DUTY - M2 HSS

Part #	Size	Dec.	OAL	Flute	Qty.
PB-0464	1/16"	.0625	1-7/8"	7/8"	12
PB-0564	5/64"	.0781	2"	1"	12
PB-0664	3/32"	.0938	2-1/4"	1-1/4"	12
PB-0764	7/64"	.1094	2-5/8"	1-1/2"	12
PB-0864	1/8"	.1250	2-3/4"	1-5/8"	12
PB-0964	9/64"	.1406	2-7/8"	1-3/4"	12
PB-1064	5/32"	.1562	3-1/8"	2"	12
PB-1164	11/64"	.1719	3-1/4"	2-1/8"	12
PB-1264	3/16"	.1875	3-1/2"	2-5/16"	12
PB-1364	13/64"	.2031	3-5/8"	2-7/16"	12
PB-1464	7/32"	.2188	3-3/4"	2-1/2"	12
PB-1564	15/64"	.2344	3-7/8"	2-5/8"	12
PB-1664	1/4"	.2500	4"	2-3/4"	12
PB-1764	17/64"	.2656	4-1/8"	2-7/8"	12
PB-1864	9/32"	.2812	4-1/4"	2-15/16"	12

Part #	Size	Dec.	OAL	Flute	Qty.
PB-1964	19/64"	.2969	4-3/8"	3-1/16"	12
PB-2064	5/16"	.3125	4-1/2"	3-3/16"	12
PB-2164	21/64"	.3281	4-5/8"	3-5/16"	6
PB-2264	11/32"	.3438	4-3/4"	3-7/16"	6
PB-2364	23/64"	.3594	4-7/8"	3-1/2"	6
PB-2464	3/8"	.3750	5"	3-5/8"	6
PB-2564	25/64"	.3906	5-1/8"	3-3/4"	6
PB-2664	13/32"	.4062	5-1/4"	3-7/8"	6
PB-2764	27/64"	.4219	5-3/8"	3-15/16"	6
PB-2864	7/16"	.4375	5-1/2"	4-1/16"	6
PB-2964	29/64"	.4531	5-5/8"	4-3/16"	6
PB-3064	15/32"	.4688	5-3/4"	4-5/16"	6
PB-3164	31/64"	.4844	5-7/8"	4-3/8"	6
PB-3264	1/2"	.5000	6"	4-1/2"	6

Black & Gold



- ◆ Jobber Length
- ◆ 135° Split Point
- ◆ Ground Flute
- ◆ Straight Shank
- ◆ Heavy Duty Web
- ◆ Black & Gold Finish
- ◆ M2 HSS



Extra Heavy Duty Web
30% thicker than even heavy duty webs, resists the extra shear stress found in deep hole drilling.

Parabolic Flute
Fast parabolic spiral allows deep hole drilling without frequent drill removal to clear chips.



Cobalt Jobber Drills - SUPER HEAVY DUTY - M42 SUPER COBALT

Part #	Size	Dec.	OAL	Flute	Qty.
CO-0464	1/16"	.0625	1-7/8"	7/8"	12
CO-0564	5/64"	.0781	2"	1"	12
CO-0664	3/32"	.0938	2-1/4"	1-1/4"	12
CO-0764	7/64"	.1094	2-5/8"	1-1/2"	12
CO-0864	1/8"	.1250	2-3/4"	1-5/8"	12
CO-0964	9/64"	.1406	2-7/8"	1-3/4"	12
CO-1064	5/32"	.1562	3-1/8"	2"	12
CO-1164	11/64"	.1719	3-1/4"	2-1/8"	12
CO-1264	3/16"	.1875	3-1/2"	2-5/16"	12
CO-1364	13/64"	.2031	3-5/8"	2-7/16"	12
CO-1464	7/32"	.2188	3-3/4"	2-1/2"	12
CO-1564	15/64"	.2344	3-7/8"	2-5/8"	12
CO-1664	1/4"	.2500	4"	2-3/4"	12
CO-1764	17/64"	.2656	4-1/8"	2-7/8"	12
CO-1864	9/32"	.2812	4-1/4"	2-15/16"	12

Part #	Size	Dec.	OAL	Flute	Qty.
CO-1964	19/64"	.2969	4-3/8"	3-1/16"	12
CO-2064	5/16"	.3125	4-1/2"	3-3/16"	12
CO-2164	21/64"	.3281	4-5/8"	3-5/16"	6
CO-2264	11/32"	.3438	4-3/4"	3-7/16"	6
CO-2364	23/64"	.3594	4-7/8"	3-1/2"	6
CO-2464	3/8"	.3750	5"	3-5/8"	6
CO-2564	25/64"	.3906	5-1/8"	3-3/4"	6
CO-2664	13/32"	.4062	5-1/4"	3-7/8"	6
CO-2764	27/64"	.4219	5-3/8"	3-15/16"	6
CO-2864	7/16"	.4375	5-1/2"	4-1/16"	6
CO-2964	29/64"	.4531	5-5/8"	4-3/16"	6
CO-3064	15/32"	.4688	5-3/4"	4-5/16"	6
CO-3164	31/64"	.4844	5-7/8"	4-3/8"	6
CO-3264	1/2"	.5000	6"	4-1/2"	6



COBALT

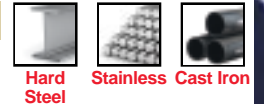

- ◆ Jobber Length
- ◆ 135° Split Point
- ◆ Ground Flute
- ◆ Straight Shank
- ◆ Heavy Duty Web
- ◆ Gold Finish
- ◆ M42 Super Cobalt





Made In



COBALT



Hard Steel Stainless Cast Iron

- ◆ Heavy Duty Spur
- ◆ M42 Super Cobalt
- ◆ High Red Hot Hardness
- ◆ Double End
- ◆ Gold Finish



Spotweld - Double End - M42 COBALT

Part #	Size	Frac.	OAL	Qty.
219DE0065	6.5 mm	1/4"	3-5/8"	5
219DE0080	8.0 mm	5/16"	3-5/8"	5
219DE0100	10.0 mm	3/8"	3-5/8"	5



Double End - M42 COBALT

Part #	Size	Dec.	OAL	Flute	Qty.
211CO0864	1/8"	.1250	2"	1/2"	12
211CO0030	#30	.1285	2"	1/2"	12



135° SPLIT POINT

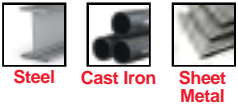

- ◆ Heavy Duty
- ◆ 135° Split Point
- ◆ M2 HSS
- ◆ Bright and Black Finish
- ◆ Automotive



Double End - M2 HSS BRIGHT

Part #	Size	Dec.	OAL	Flute	Qty.
211DE0764	7/64"	.1094	1-7/8"	1/2"	12
211DE0864	1/8"	.1250	2"	1/2"	12
211DE0964	9/64"	.1406	2"	1/2"	12
211DE1064	5/32"	.1562	2-1/16"	1/2"	12
211DE1264	3/16"	.1875	2-3/16"	1/2"	12
211DE1464	7/32"	.2188	2-3/8"	1/2"	12
211DE1664	1/4"	.2500	2-1/2"	1/2"	12
211DE0030	#30	.1285	2"	1/2"	12



Double End - M2 HSS BLACK

Part #	Size	Dec.	OAL	Flute	Qty.
211DE0864-B	1/8"	.1250	2"	1/2"	12
211DE0030-B	#30	.1285	2"	1/2"	12



CARDED

Part # SE-006-16
6 Pc. Screw Extractor Set
 #1, #2, #3, #4, #5, #6



Screw Extractor - LEFT HAND SPIRAL FLUTE

Part #	Size	Shank Diameter	Removes Screws	or	Pipe
SE0001	1	5/64"	3/32" to 5/32"		
SE0002	2	7/64"	5/32" to 7/32"		
SE0003	3	5/32"	7/32" to 9/32"		
SE0004	4	1/4"	9/32" to 3/8"		1/8" Pipe
SE0005	5	19/64"	3/8" to 5/8"		1/4" Pipe
SE0006	6	13/32"	5/8" to 7/8"		3/8" Pipe
SE0007	7	17/32"	7/8" to 1-1/8"		1/2" Pipe
SE0008	8	13/16"	1-1/8" to 1-3/8"		3/4" Pipe
SE0009	9	1-1/16"	1-3/8" to 2"		1" Pipe



6" Cobalt Aircraft - M35 COBALT

Part #	Size	Dec.	OAL	Flute	Qty.
212CO0464	1/16"	.0625	6"	7/8"	6
212CO0864	1/8"	.1250	6"	1-5/8"	6
212CO1064	5/32"	.1562	6"	2"	6
212CO1164	11/64"	.1719	6"	2-1/8"	6
212CO1264	3/16"	.1875	6"	2-5/16"	6
212CO1464	7/32"	.2188	6"	2-1/2"	6
212CO1664	1/4"	.2500	6"	2-3/4"	6
212CO2064	5/16"	.3125	6"	3-3/16"	1
212CO2464	3/8"	.3750	6"	3-5/8"	1



COBALT



- ◆ Straight Shank
- ◆ 135° Split Point
- ◆ Ground Flute
- ◆ Extra Flexibility
- ◆ Heavy Duty Web
- ◆ Gold Finish
- ◆ M35 Cobalt



6" Aircraft - M2 HSS

Part #	Size	Dec.	OAL	Flute	Qty.
212SP0464	1/16"	.0625	6"	7/8"	6
212SP0864	1/8"	.1250	6"	1-5/8"	6
212SP0964	9/64"	.1406	6"	1-3/4"	6
212SP1064	5/32"	.1562	6"	2"	6
212SP1164	11/64"	.1719	6"	2-1/8"	6
212SP1264	3/16"	.1875	6"	2-5/16"	6
212SP1364	13/64"	.2031	6"	2-7/16"	6
212SP1464	7/32"	.2188	6"	2-1/2"	6
212SP1564	15/64"	.2344	6"	2-5/8"	6
212SP1664	1/4"	.2500	6"	2-3/4"	6
212SP1764	17/64"	.2656	6"	2-7/8"	6
212SP1864	9/32"	.2812	6"	2-15/16"	6
212SP2064	5/16"	.3125	6"	3-3/16"	1
212SP2264	11/32"	.3438	6"	3-7/16"	1
212SP2464	3/8"	.3750	6"	3-5/8"	1
212SP2864	7/16"	.4375	6"	4-1/16"	1
212SP3264	1/2"	.5000	6"	4-1/2"	1

18" Aircraft - M2 HSS

Part #	Size	Dec.	OAL	Flute	Qty.
215SP1264	3/16"	.1875	18"	2-5/16"	1
215SP1664	1/4"	.2500	18"	2-3/4"	1
215SP2064	5/16"	.3125	18"	3-3/16"	1
215SP2464	3/8"	.3750	18"	3-5/8"	1
215SP3264	1/2"	.5000	18"	4-1/2"	1

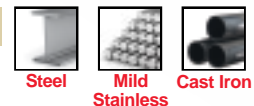

- ◆ Straight Shank
- ◆ 135° Split Point
- ◆ Ground Flute
- ◆ Extra Flexibility
- ◆ Heavy Duty Web
- ◆ Black Oxide Finish
- ◆ M2 HSS



6" Wire Gauge Aircraft - M2 HSS

Part #	Size	Dec.	OAL	Flute	Qty.
213SP0001	1	.2280	6"	2-5/8"	6
213SP0002	2	.2210	6"	2-5/8"	6
213SP0007	7	.2010	6"	2-7/16"	6
213SP0009	9	.1960	6"	2-7/16"	6
213SP0010	10	.1935	6"	2-7/16"	6
213SP0011	11	.1910	6"	2-5/16"	6
213SP0016	16	.1770	6"	2-3/16"	6
213SP0017	17	.1730	6"	2-3/16"	6
213SP0021	21	.1590	6"	2-1/8"	6
213SP0026	26	.1470	6"	1-7/8"	6
213SP0029	29	.1360	6"	1-3/4"	6
213SP0030	30	.1285	6"	1-5/8"	6
213SP0031	31	.1200	6"	1-5/8"	6
213SP0040	40	.0980	6"	1-3/8"	6

12" Aircraft - M2 HSS

Part #	Size	Dec.	OAL	Flute	Qty.
214SP0864	1/8"	.1250	12"	1-5/8"	1
214SP1064	5/32"	.1562	12"	2"	1
214SP1264	3/16"	.1875	12"	2-5/16"	1
214SP1464	7/32"	.2188	12"	2-1/2"	1
214SP1664	1/4"	.2500	12"	2-3/4"	1
214SP1864	9/32"	.2812	12"	2-15/16"	1
214SP2064	5/16"	.3125	12"	3-3/16"	1
214SP2264	11/32"	.3438	12"	3-7/16"	1
214SP2464	3/8"	.3750	12"	3-5/8"	1
214SP2864*	7/16"	.4375	12"	4-1/16"	1
214SP3264*	1/2"	.5000	12"	4-1/2"	1

* 3/8" Shank

12" Wire Gauge Aircraft - M2 HSS

Part #	Size	Dec.	OAL	Flute	Qty.
213SP1201	1	.2280	12"	2-5/8"	1
213SP1207	7	.2010	12"	2-7/16"	1
213SP1210	10	.1935	12"	2-7/16"	1
213SP1221	21	.1590	12"	2-1/8"	1
213SP1229	29	.1360	12"	1-3/4"	1
213SP1230	30	.1285	12"	1-5/8"	1
213SP1231	31	.1200	12"	1-5/8"	1
213SP1240	40	.0980	12"	1-3/8"	1



13 PC Jobber Sets - Straight Shank

Part #	Set	Sizes	Type	Drills	Point
AD-13	13 pc	1/16" → 1/4" x 64ths	Black Oxide	p.11	118°
BT-13	13 pc	1/16" → 1/4" x 64ths	Bright Finish	p.10	118°
SP-13	13 pc	1/16" → 1/4" x 64ths	Black Oxide	p.12	135° S.P.
BG-13	13 pc	1/16" → 1/4" x 64ths	Black & Gold	p.17	135° S.P.
MRO-13F	13 pc	1/16" → 1/4" x 64ths	MRO 3-FLAT*	p.20	135° S.P.
CX-13	13 pc	1/16" → 1/4" x 64ths	Cobalt	p.22	135° S.P.
TI-13	13 pc	1/16" → 1/4" x 64ths	Titanium	p.24	135° S.P.
PB-13	13 pc	1/16" → 1/4" x 64ths	Parabolic*	p.25	135° S.P.
CO-13	13 pc	1/16" → 1/4" x 64ths	Cobalt*	p.25	135° S.P.

◆ Metal Huot Case



* Made in USA

S.P. = Split Point



15 PC Jobber Sets - Straight Shank

Part #	Set	Sizes	Type	Drills	Point
SP-15	15 pc	1/16" → 1/2" x 32nds	Black Oxide	p.12	135° S.P.
BG-15	15 pc	1/16" → 1/2" x 32nds	Black & Gold	p.17	135° S.P.
MRO-15F	15 pc	1/16" → 1/2" x 32nds	MRO 3-FLAT*	p.20	135° S.P.
CX-15	15 pc	1/16" → 1/2" x 32nds	Cobalt	p.22	135° S.P.
PB-15	15 pc	1/16" → 1/2" x 32nds	Parabolic*	p.25	135° S.P.
CO-15	15 pc	1/16" → 1/2" x 32nds	Cobalt*	p.25	135° S.P.

◆ Metal Huot Case



* Made in USA

S.P. = Split Point



29 PC Jobber Sets - Straight Shank

Part #	Set	Sizes	Type	Drills	Point
AD-29	29 pc	1/16" → 1/2" x 64ths	Black Oxide	p.11	118°
BT-29	29 pc	1/16" → 1/2" x 64ths	Bright Finish	p.10	118°
SP-29	29 pc	1/16" → 1/2" x 64ths	Black Oxide	p.12	135° S.P.
BG-29	29 pc	1/16" → 1/2" x 64ths	Black & Gold	p.17	135° S.P.
MRO-29F	29 pc	1/16" → 1/2" x 64ths	MRO 3-FLAT*	p.20	135° S.P.
CX-29	29 pc	1/16" → 1/2" x 64ths	Cobalt	p.22	135° S.P.
TI-29	29 pc	1/16" → 1/2" x 64ths	Titanium	p.24	135° S.P.
PB-29	29 pc	1/16" → 1/2" x 64ths	Parabolic*	p.25	135° S.P.
CO-29	29 pc	1/16" → 1/2" x 64ths	Cobalt*	p.25	135° S.P.

◆ Metal Huot Case



* Made in USA

S.P. = Split Point

29 PC Jobber Sets - 3/8" Shank

Part #	Set	Sizes	Type	Drills	Point
SP-29R	29 pc	1/16" → 1/2" x 64ths	Black Oxide	p.13	135° S.P.
BG-29R	29 pc	1/16" → 1/2" x 64ths	Black & Gold	p.18	135° S.P.
CX-29R	29 pc	1/16" → 1/2" x 64ths	Cobalt	p.23	135° S.P.

1/16" - 3/8" STRAIGHT SHANK, 25/64" - 1/2" WITH 3/8" SHANK

S.P. = Split Point

◆ Metal Huot Case

29 PC Jobber Sets - Bullet Case

Part #	Set	Sizes	Type	Drills	Point
BX-1	29 pc	1/16" → 1/2" x 64ths	Black Oxide	p. 12	135° S.P.
BT-1	29 pc	1/16" → 1/2" x 64ths	Bright	p. 10	118°
BG-1	29 pc	1/16" → 1/2" x 64ths	Black & Gold	p. 17	135° S.P.
MC-1	29 pc	1/16" → 1/2" x 64ths	Mechanics 3-FLAT*	p. 18	135° S.P.
MRO-1F	29 pc	1/16" → 1/2" x 64ths	MRO 3-FLAT*	p. 20	135° S.P.
CX-1	29 pc	1/16" → 1/2" x 64ths	Cobalt	p. 22	135° S.P.
TI-1	29 pc	1/16" → 1/2" x 64ths	Titanium	p. 24	135° S.P.
PB-1	29 pc	1/16" → 1/2" x 64ths	Parabolic*	p. 25	135° S.P.
CO-1	29 pc	1/16" → 1/2" x 64ths	Cobalt*	p. 25	135° S.P.

◆ Huot Bullet Case



* Made in USA

S.P. = Split Point



8 PC Silver & Deming Sets

Part #	Set	Sizes	Type	Drills	Point
AD-8	8 pc	See Below	Black Oxide	p.15	118°
BG-8	8 pc	See Below	Black & Gold	p.19	118°
CX-8	8 pc	See Below	Cobalt	p.23	135° S.P.

ALL SETS: 9/16", 5/8", 11/16", 3/4", 13/16", 7/8", 15/16", 1"

S.P. = Split Point

◆ Metal Huot Case



60 PC Wire Gauge Sets

Part #	Set	Sizes	Type	Drills	Point
SP-60	60 pc	#1 → #60	Black Oxide	p.12	135° S.P.
BG-60	60 pc	#1 → #60	Black & Gold	p.17	135° S.P.
CX-60	60 pc	#1 → #60	Cobalt	p.22	135° S.P.

S.P. = Split Point

◆ Metal Huot Case





LETTER A → Z Sets - Straight Shank

Part #	Set	Sizes	Type	Drills	Point
SP-AZ	26 pc	A → Z	Black Oxide	p.13	135° S.P.
BG-AZ	26 pc	A → Z	Black & Gold	p.19	135° S.P.

◆ Metal Huot Case

S.P. = Split Point



115 PC MASTER Sets - Straight Shank

Part #	Set	Sizes	Type	Drills	Point
SP-115	115 pc	See Below	Black Oxide	p.12	135° S.P.
BG-115	115 pc	See Below	Black & Gold	p.17	135° S.P.
CX-115	115 pc	See Below	Cobalt	p.22	135° S.P.

JOBBER SIZES: 1/16" → 1/2", WIRE GAUGE DRILL SIZES #1 → #60,
 LETTER SIZES: A → Z. STRAIGHT SHANK.

◆ Metal Huot Case

S.P. = Split Point



METRIC Sets - Straight Shank

Part #	Set	Sizes	Type	Drills	Point
MM-11	11 pc	1.00MM → 6.00MM	Black Oxide	p.13	118°
MM-25	25 pc	1.00MM → 13.00MM	Black Oxide	p.13	118°

◆ Metal Huot Case



TAP & DRILL Sets - CARBON / M2 HSS TAPS

Part #	Sizes	Type	Drills	Point
CD-SP-019	See Below	Carbon Taps	p.11	118°
TD-SP-019	See Below	M2 HSS Taps	p.12	135° S.P.

HSS DRILL BIT SIZES: #36, #29, #25, #21, #7, F, 5/16", U, 27/64"
 TAP SIZES: 6-32, 8-32, 10-24, 10-32, 1/4"-20, 5/16"-18, 3/8"-16, 7/16"-14, 1/2"-13

◆ Metal Huot Case

525 Pc. Dispenser Contains:

24- 1/16"	24- 5/64"	48- 3/32"	24- 7/64"	72- 1/8"
24- 9/64"	36- 5/32"	24- 11/64"	48- 3/16"	24- 13/64"
24- 7/32"	12- 15/64"	60- 1/4"	3- 17/64"	12- 9/32"
3- 19/64"	12- 5/16"	3- 21/64"	3- 11/32"	3- 23/64"
12- 3/8"	3- 25/64"	3- 13/32"	3- 27/64"	6- 7/16"
3- 29/64"	3- 15/32"	3- 31/64"	6- 1/2"	

This attractive drill bit merchandiser puts all 29 essential jobber sizes at your fingertips. Made of heavy duty steel construction, this deep red cabinet dispenser fits perfectly on any counter top. Comes with lock and key.



DISPLAY - PART# 13125
14" Out X 15"H X 12"W

525 PC Jobber Countertop Dispenser

Part #	Set	Sizes	Type	Drills	Point
SP-525	525 pc	1/16" → 1/2" x 64ths	Black Oxide	p.12	135° S.P.
BG-525	525 pc	1/16" → 1/2" x 64ths	Black & Gold	p.17	135° S.P.
MC-525	525 pc	1/16" → 1/2" x 64ths	Mechanics*	p.18	135° S.P.
MRO-525	525 pc	1/16" → 1/2" x 64ths	MRO 3-FLAT*	p.20	135° S.P.
CX-525	525 pc	1/16" → 1/2" x 64ths	Cobalt	p.22	135° S.P.

S.P. = Split Point



* Made in USA

◆ Metal Huot Case

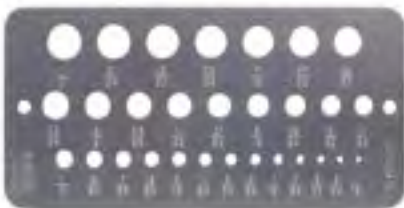

Metal Drill Gauges

Part #	Description	Sizes
29GAUGE	29 Hole Gauge	1/16" → 1/2"
60GAUGE	60 Hole Gauge	#1 → #60 Wire



- ◆ M2 HSS
- ◆ Milled Body
- ◆ Ground Flute
- ◆ Sold Individually



Single (1) Flute Countersinks - M2 HSS

60° Part #	82° Part #	90° Part #	100° Part #	Size	Shank Diameter	Shank Length	OAL
CI-60-1264	CI-82-1264	CI-90-1264	CI-100-1264	3/16"	3/16"	3/4"	1-1/2"
CI-60-1664	CI-82-1664	CI-90-1664	CI-100-1664	1/4"	1/4"	3/4"	2"
CI-60-2064	CI-82-2064	CI-90-2064	CI-100-2064	5/16"	1/4"	1"	2"
CI-60-2464	CI-82-2464	CI-90-2464	CI-100-2464	3/8"	1/4"	1"	2"
CI-60-3264	CI-82-3264	CI-90-3264	CI-100-3264	1/2"	1/4"	1"	2"
CI-60-4064	CI-82-4064	CI-90-4064	CI-100-4064	5/8"	3/8"	1-1/8"	2-3/4"
CI-60-4864	CI-82-4864	CI-90-4864	CI-100-4864	3/4"	3/8"	1-5/16"	2-3/4"
CI-60-5064	CI-82-5064	CI-90-5064	CI-100-5064	7/8"	1/2"	1-5/16"	2-3/4"
CI-60-6464	CI-82-6464	CI-90-6464	CI-100-6464	1"	1/2"	1-5/16"	2-3/4"



Three (3) Flute Countersinks - M2 HSS

60° Part #	82° Part #	90° Part #	100° Part #	Size	Shank Diameter	Shank Length	OAL
R3-60-1664	R3-82-1664	R3-90-1664	R3-100-1664	1/4"	3/16"	3/4"	1-1/2"
R3-60-2464	R3-82-2464	R3-90-2464	R3-100-2464	3/8"	1/4"	7/8"	2-3/4"
R3-60-3264	R3-82-3264	R3-90-3264	R3-100-3264	1/2"	3/8"	1"	2"
R3-60-4064	R3-82-4064	R3-90-4064	R3-100-4064	5/8"	3/8"	1"	2-1/4"
R3-60-4864	R3-82-4864	R3-90-4864	R3-100-4864	3/4"	1/2"	1-1/4"	2-5/8"
R3-60-6464	R3-82-6464	R3-90-6464	R3-100-6464	1"	1/2"	1-1/4"	2-3/4"



- ◆ 1/4" Hex Impact Shank
- ◆ M2 HSS
- ◆ Window & Door Installs
- ◆ Chatterless
- ◆ Sold Individually



IMPACT
1/4" HEX IMPACT SHANK



Zero Flute Countersinks - M2 HSS - 82°

Part #	Degree	Screw Size	Body Dia.	Shank	OAL
ZF-1	82°	No. 2, 3, 4	1/4"	1/4" HEX	1-27/32"
ZF-2	82°	No. 5, 6, 8	11/32"	1/4" HEX	2"
ZF-3	82°	No. 10, 12, 14	9/16"	1/4" HEX	2-5/16"



- ◆ 1/4" Hex Impact Shank
- ◆ Inner Reamer
- ◆ Retail Packaging



IMPACT
1/4" HEX IMPACT SHANK

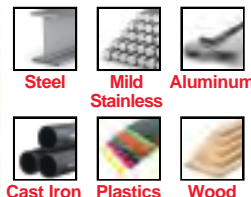

Rim Champ - M2 HSS - 90°

Part #	Description	Size	Qty.
RIM-01	Inner Reamer (HSS)	1/8" - 3/4"	1
RIM-02	Inner Reamer (HSS)	3/16" - 7/8"	1



Bar Champ - Small - M2 HSS Blade

Part #	Description	Size	Qty.
BAR-01	Outer Reamer (HSS)	1/8" - 3/4"	1



Bar Champ - Small - Carbide Blade

Part #	Description	Size	Qty.
BAR-01C	Outer Reamer (Carbide)	1/8" - 3/4"	1



IMPACT
1/4" HEX IMPACT SHANK

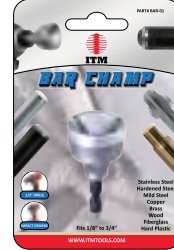
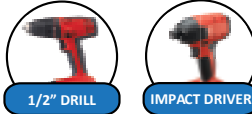

- ◆ 1/4" Hex Impact Shank
- ◆ Outer Reamer
- ◆ Retail Packaging

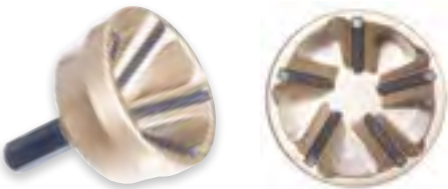

Bar Champ - Medium - Carbide Blade

Part #	Description	Size	Qty.
BAR-02C	Outer Reamer (Carbide)	1/2" - 1-3/8"	1

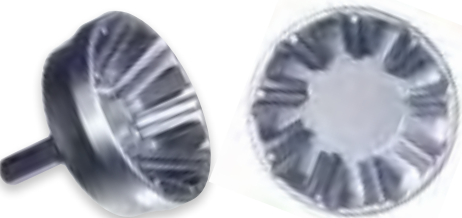

Bar Champ - Large - Carbide Blade

Part #	Description	Size	Qty.
BAR-03C	Outer Reamer (Carbide)	1-3/8" - 2-1/8"	1



- ◆ 3/8" Hex Shank
- ◆ Outer Reamer
- ◆ Retail Packaging



For Use With:

- Threaded Rod
- Round Stock
- Bar Stock
- Rebar
- Bolts



Works Great For
Damaged Bolts
And Fasteners!

BAR CHAMP™



TAPER



8 to 10 threads chamfered for easy thread starting in tough material.

PLUG



3 to 5 threads chamfered for general use when tapping to bottom of hole is not critical. **This is the most popular tap of all three styles.**

BOTTOM



1-1/2 threads chamfered for use after threads have been started. Used for clean tapping to bottom of holes.

NC = National Course
NF = National Fine

Packaging:
Carbon Steel Taps

10 PC. PER PACK FROM
4 - 40 → 1/2" - 20
5 PC. PER PACK FROM
9/16" - 12 → 7/8 - 14
SOLD 1 PC. OVER 7/8" - 14

HSS Taps

6 PC. PER PACK FROM
4 - 40 → 5/8" - 18
SOLD 1 PC. OVER 5/8" - 18

DRILL THIS SIZE HOLE			TO TAP FOR THIS BOLT OR SCREW
DECIMAL INCHES	DRILL SIZE	NEAREST FRACTION	
.0469"	3/64"	3/64"	0-80 NF
.0595"	No. 53	none	1-64 NC
.0595"	No. 53	1/16"	1-72 NF
.0700"	No. 50	none	2-56 NC
.0700"	No. 50	none	2-64 NF
.0785"	No. 47	5/64"	3-48 NC
.0820"	No. 45	none	3-56 NF
.0860"	No. 44	none	4-36 NS
.0890"	No. 43	3/32"	4-40 NC
.0935"	No. 42	3/32"	4-48 NF
.0984"	2.5mm	none	3mm-0.60mm
.1015"	No. 38	none	1/8-40 NS
.1015"	No. 38	none	5-40 NC
.1040"	No. 37	none	5-44 NF
.1100"	No. 35	7/64"	6-32 NC
.1110"	No. 34	none	6-36 NS
.1130"	No. 33	none	6-40 NF
.1200"	No. 31	none	6-48 NS
.1338"	3.4mm	none	4mm-0.70mm
.1338"	3.4mm	none	4mm-0.75mm
.1360"	No. 29	none	8-32 NC
.1360"	No. 29	9/64"	8-36 NF
.1405"	No. 28	none	8-40 NS
.1470"	No. 26	none	3/16-24 NS
.1495"	No. 25	5/32"	10-24 NC
.1570"	No. 22	none	3/16-32 NS
.1590"	No. 21	5/32"	10-32 NF
.1653"	4.2mm	none	5mm-0.90mm
.1693"	4.3mm	none	5mm-0.80mm
.1770"	No. 16	11/64"	12-24 NC
.1820"	No. 14	3/16"	12-28 NF
.1850"	No. 13	none	12-32 NEF
.1935"	No. 10	none	14-20 NS
.2010"	No. 7	13/64"	1/4-20 NC
.2010"	No. 7	none	14-24 NS
.2047"	5.2mm	none	6mm-1.00mm
.2090"	No. 4	none	1/4-24 NS
.2130"	No. 3	7/32"	1/4-28 NF
.2188"	7/32"	7/32"	1/4-32 NEF
.2280"	No. 1	none	1/4-40 NS
.2401"	6.1mm	15/64"	7mm-1.00mm
.2570"	Ltr. F	17/64"	5/16-18 NC
.2716"	6.9mm	17/64"	8mm-1.25mm
.2720"	Ltr. I	none	5/16-24 NF
.2795"	7.1mm	none	8mm-1.00mm
.2812"	9/32"	9/32"	5/16-32 NEF
.3110"	7.9mm	none	9mm-1.25mm
.3125"	5/16"	5/16"	3/8-16 NC

DRILL THIS SIZE HOLE			TO TAP FOR THIS BOLT OR SCREW
DECIMAL INCHES	DRILL SIZE	NEAREST FRACTION	
.3189"	8.1mm	none	9mm-1.00mm
.3268"	8.3mm	none	9mm-0.75mm
.3320"	Ltr. Q	21/64"	3/8-24 NF
.3425"	8.7mm	none	10mm-1.50mm
.3503"	8.9mm	11/32"	10mm-1.25mm
.3583"	9.1mm	none	*10mm-1.00mm
.3680"	Ltr. U	23/64"	7/16"-14 NC
.3818"	9.7mm	none	11mm-1.50mm
.3906"	25/64"	25/64"	7/16-20 NF
.4133"	10.5mm	none	12mm-1.75mm
.4212"	10.7mm	27/64"	12mm-1.50mm
.4219"	27/64"	27/64"	1/2-13 NC
.4291"	10.9mm	27/64"	*12mm-1.25mm
.4531"	29/64"	29/64"	1/2-20 NF
.4531"	29/64"	29/64"	1/2-24 NS
.4803"	12.2mm	none	14mm-2.00mm
.4844"	31/64"	31/64"	9/16-12 NC
.4999"	12.7mm	none	14mm-1.50mm
.5039"	12.8mm	none	*14mm-1.25mm
.5156"	33/64"	33/64"	9/16-18 NF
.5312"	17/32"	17/32"	5/8-11 NC
.5590"	14.2mm	35/64"	16mm-2.00mm
.5781"	37/64"	37/64"	5/8-18 NF
.5787"	14.7mm	none	16mm-1.50mm
.5938"	19/32"	19/32"	11/16-11 NS
.6220"	15.8mm	39/64"	18mm-2.50mm
.6250"	5/8"	5/8"	11/16-16 NS
.6562"	21/32"	21/32"	3/4-10 NC
.6614"	16.8mm	none	*18mm-1.50mm
.6875"	11/16"	11/16"	3/4-16 NF
.7008"	17.8mm	11/16"	20mm-2.50mm
.7656"	49/64"	49/64"	7/8-9 NC
.8125"	13/16"	13/16"	7/8-14 NF
.8228"	20.9mm	none	22mm-1.50mm
.8281"	53/64"	53/64"	*7/8-18 NS
.8425"	21.4mm	53/64"	24mm-3.00mm
.8750"	7/8"	7/8"	1-8 NC
.8779"	22.3mm	none	24mm-2.00mm
.9219"	59/64"	59/64"	1-12 NF
.9375"	15/16"	15/16"	1-14 NS
.9844"	63/64"	63/64"	1-1/8 - 7 NC
1.0469"	1-3/64"	1-3/64"	1-1/8 - 12 NF
1.1094"	1-7/64"	1-7/64"	1-1/4 - 7 NC
1.1719"	1-11/64"	1-11/64"	1-1/4 - 12 NF
1.2188"	1-7/32"	1-7/32"	1-3/8 - 6 NC
1.2969"	1-19/64"	1-19/64"	1-3/8 - 12 NF
1.3468"	1-11/32"	1-11/32"	1-1/2 - 6 NC
1.4219"	1-27/64"	1-27/64"	1-1/2 - 12 NF

**INTERNAL
PIPE THREADING**

(HSS) NPT Taper Pipe Taps

Part #	Size	Threads Per Inch NPT Only	No. Of Flutes	OAL	Thread Length
265TP0464	1/16"	27	4	2-1/8"	11/16"
265TP0864	1/8"	27	4	2-1/8"	3/4"
265TP1664	1/4"	18	4	2-7/16"	1-1/16"
265TP2464	3/8"	18	4	2-9/16"	1-1/16"
265TP3264	1/2"	14	4	3-1/8"	1-3/8"
265TP4864	3/4"	14	5	3-1/4"	1-3/8"
265TP6464	1"	11.5	5	3-3/4"	1-3/4"
265TP8064	1-1/4"	11.5	5	4"	1-3/4"
265TP9664	1-1/2"	11.5	7	4-1/4"	1-3/4"
265TP9964	2"	11.5	7	4-1/2"	1-3/4"



- ◆ National Pipe Tap
- ◆ M2 HSS
- ◆ Ground Thread
- ◆ Heavy Duty

SOLD INDIVIDUALLY IN PLASTIC TUBES.

(Carbon Steel) NPT Taper Pipe Taps

Part #	Size	Threads Per Inch NPT Only	No. Of Flutes	OAL	Thread Length
NPT0464	1/16"	27	4	2-1/8"	11/16"
NPT0864	1/8"	27	4	2-1/8"	3/4"
NPT1664	1/4"	18	4	2-7/16"	1-1/16"
NPT2464	3/8"	18	4	2-9/16"	1-1/16"
NPT3264	1/2"	14	4	3-1/8"	1-3/8"
NPT4864	3/4"	14	5	3-1/4"	1-3/8"
NPT6464	1"	11.5	5	3-3/4"	1-3/4"
NPT8864	1-1/4"	11.5	5	4"	1-3/4"
NPT9664	1-1/2"	11.5	7	4-1/4"	1-3/4"
NPT9964	2"	11.5	7	4-1/2"	1-3/4"



- ◆ National Pipe Tap
- ◆ Carbon Steel
- ◆ Ground Thread
- ◆ General Purpose

SOLD INDIVIDUALLY IN PLASTIC TUBES.

**NPT
TAP-DRILL CHART**



DRILL THIS SIZE HOLE			TO TAP FOR THIS BOLT OR SCREW
DECIMAL INCHES	DRILL SIZE	NEAREST FRACTION	
.3390"	Ltr. R	none	1/8-27 NPT
.4375"	7/16"	7/16"	1/4-18 NPT
.5781"	37/64"	37/64"	3/8- 18 NPT
.7031"	45/64"	45/64"	1/2-14 NPT
.9219"	59/64"	59/64"	3/4-14 NPT
1.1562"	1-5/32"	1-5/32"	1 - 11-1/2 NPT
1.5000"	1-1/2"	1-1/2"	1-1/4 - 11-1/2 NPT
1.7344"	1-47/64"	1-47/64"	1-1/2 - 11-1/2 NPT
2.2188"	2-3/16"	2-3/16"	2 - 11-1/2 NPT

i Wrenches will accommodate all HSS & Carbon Hand Taps within O.D. size.
O.D. Size = Actual Tap Size (machine screw thread).

T-Handle Tap Wrench

Part #	O.D. Size
271TT0001	#0 - 1/4"
271TT0002	#10 - 1/2"



Tap Reamer Wrench

Part #	O.D. Size	Size
270TW0000	#0-1/4"	TW0
270TW0004	#0-3/8"	TW4
270TW0005	#7-1/2"	TW5
270TW0006	#7-3/4"	TW6
270TW0007	1/4" → 1-1/8"	TW7





Carbon Steel Hand Taps - MACHINE SCREW

PART #			Machine Screw Thread	No. Of Flutes	Ground Thread Limit	OAL	Use Thread Length	Drill Size
TAPER	PLUG	BOTTOM						
C62NC0004	C63NC0004	C64NC0004	4-40 NC	3	H2	1-7/8"	9/16"	43
C62NF0004	C63NF0004	C64NF0004	4-48 NF	3	H2	1-7/8"	9/16"	42
C62NC0005	C63NC0005	C64NC0005	5-40 NC	3	H2	1-15/16"	7/8"	38
C62NF0005	C63NF0005	C64NF0005	5-44 NF	3	H2	1-15/16"	7/8"	37
C62NC0006	C63NC0006	C64NC0006	6-32 NC	3	H2	2"	11/16"	35
C62NF0006	C63NF0006	C64NF0006	6-40 NF	3	H2	2"	11/16"	33
C62NC0008	C63NC0008	C64NC0008	8-32 NC	4	H3	2-1/8"	3/4"	29
C62NF0008	C63NF0008	C64NF0008	8-36 NF	4	H3	2-1/8"	3/4"	29
C62NC0010	C63NC0010	C64NC0010	10-24 NC	4	H3	2-3/8"	7/8"	25
C62NF0010	C63NF0010	C64NF0010	10-32 NF	4	H3	2-3/8"	7/8"	21
C62NC0012	C63NC0012	C64NC0012	12-24 NC	4	H3	2-3/8"	15/16"	16
C62NF0012	C63NF0012	C64NF0012	12-28 NF	4	H3	2-3/8"	15/16"	14

Carbon Steel Hand Taps - FRACTIONAL

PART #			Machine Screw Thread	No. Of Flutes	Ground Thread Limit	OAL	Use Thread Length	Drill Size
TAPER	PLUG	BOTTOM						
C65NC0310	C66NC0310	C67NC0310	1/4"-20 NC	4	H3	2-1/2"	1"	7
C65NF0312	C66NF0312	C67NF0312	1/4"-28 NF	4	H3	2-1/2"	1"	3
C65NC0315	C66NC0315	C67NC0315	5/16"-18 NC	4	H3	2-23/32"	1-1/8"	F
C65NF0316	C66NF0316	C67NF0316	5/16"-24 NF	4	H3	2-23/32"	1-1/8"	I
C65NC0318	C66NC0318	C67NC0318	3/8"-16 NC	4	H3	2-15/16"	1-1/4"	5/16"
C65NF0319	C66NF0319	C67NF0319	3/8"-24 NF	4	H3	2-15/16"	1-1/4"	Q
C65NC0320	C66NC0320	C67NC0320	7/16"-14 NC	4	H3	3-5/32"	1-7/16"	U
C65NF0321	C66NF0321	C67NF0321	7/16"-20 NF	4	H3	3-5/32"	1-7/16"	25/64"
C65NC0322	C66NC0322	C67NC0322	1/2"-13 NC	4	H3	3-3/8"	1-21/32"	27/64"
C65NF0323	C66NF0323	C67NF0323	1/2"-20 NF	4	H3	3-3/8"	1-21/32"	29/64"
C65NC0325	C66NC0325	C67NC0325	9/16"-12 NC	4	H3	3-19/32"	1-21/32"	31/64"
C65NF0326	C66NF0326	C67NF0326	9/16"-18 NF	4	H3	3-19/32"	1-21/32"	33/64"
C65NC0327	C66NC0327	C67NC0327	5/8"-11 NC	4	H3	3-13/16"	1-13/16"	17/32"
C65NF0328	C66NF0328	C67NF0328	5/8"-18 NF	4	H3	3-13/16"	1-13/16"	37/64"
C65NC0331	C66NC0331	C67NC0331	3/4"-10 NC	4	H3	4-1/4"	2"	21/32"
C65NF0332	C66NF0332	C67NF0332	3/4"-16 NF	4	H3	4-1/4"	2"	11/16"
C65NC0333	C66NC0333	C67NC0333	7/8"-9 NC	4	H4	4-11/16"	2-7/32"	49/64"
C65NF0334	C66NF0334	C67NF0334	7/8"-14 NF	4	H4	4-11/16"	2-7/32"	13/16"
C65NC0335	C66NC0335	C67NC0335	1"-8 NC	4	H4	5-1/8"	2-1/2"	7/8"
C65NF0336	C66NF0336	C67NF0336	1"-12 NF	4	H4	5-1/8"	2-1/2"	59/64"
C65NS0337	C66NS0337	C67NS0337	1"-14 NS	4	H4	5-1/8"	2-1/2"	15/16"
C65NC0338	C66NC0338	C67NC0338	1-1/8"- 7 NC	4	H4	5-7/16"	2-9/16"	63/64"



Mild Steel Cast Iron Aluminum

Carbon Steel Taps

10 PC. PER PACK FROM
4 - 40 → 1/2" - 20
5 PC. PER PACK FROM
9/16" - 12 → 7/8 - 14
SOLD 1 PC. OVER 7/8" - 14

- ◆ Carbon Steel
- ◆ Ground Thread
- ◆ General Purpose

(HSS) High Speed Steel Hand Taps - MACHINE SCREW GROUND THREAD

PART #			Machine Screw Thread	No. Of Flutes	Ground Thread Limit	OAL	Use Thread Length	Drill Size
TAPER	PLUG	BOTTOM						
262NC0004	263NC0004	264NC0004	4-40 NC	3	H2	1-7/8"	9/16"	43
262NF0004	263NF0004	264NF0004	4-48 NF	3	H2	1-7/8"	9/16"	42
262NC0005	263NC0005	264NC0005	5-40 NC	3	H2	1-15/16"	7/8"	38
262NF0005	263NF0005	264NF0005	5-44 NF	3	H2	1-15/16"	7/8"	37
262NC0006	263NC0006	264NC0006	6-32 NC	3	H2	2"	11/16"	35
262NF0006	263NF0006	264NF0006	6-40 NF	3	H2	2"	11/16"	33
262NC0008	263NC0008	264NC0008	8-32 NC	4	H3	2-1/8"	3/4"	29
262NF0008	263NF0008	264NF0008	8-36 NF	4	H3	2-1/8"	3/4"	29
262NC0010	263NC0010	264NC0010	10-24 NC	4	H3	2-3/8"	7/8"	25
262NF0010	263NF0010	264NF0010	10-32 NF	4	H3	2-3/8"	7/8"	21
262NC0012	263NC0012	264NC0012	12-24 NC	4	H3	2-3/8"	15/16"	16
262NF0012	263NF0012	264NF0012	12-28 NF	4	H3	2-3/8"	15/16"	14



(HSS) High Speed Steel Hand Taps - FRACTIONAL GROUND THREAD

PART #			Machine Screw Thread	No. Of Flutes	Ground Thread Limit	OAL	Use Thread Length	Drill Size
TAPER	PLUG	BOTTOM						
265NC0310	266NC0310	267NC0310	1/4"-20 NC	4	H3	2-1/2"	1"	7
265NF0312	266NF0312	267NF0312	1/4"-28 NF	4	H3	2-1/2"	1"	3
265NC0315	266NC0315	267NC0315	5/16"-18 NC	4	H3	2-23/32"	1-1/8"	F
265NF0316	266NF0316	267NF0316	5/16"-24 NF	4	H3	2-23/32"	1-1/8"	I
265NC0318	266NC0318	267NC0318	3/8"-16 NC	4	H3	2-15/16"	1-1/4"	5/16"
265NF0319	266NF0319	267NF0319	3/8"-24 NF	4	H3	2-15/16"	1-1/4"	Q
265NC0320	266NC0320	267NC0320	7/16"-14 NC	4	H3	3-5/32"	1-7/16"	U
265NF0321	266NF0321	267NF0321	7/16"-20 NF	4	H3	3-5/32"	1-7/16"	25/64"
265NC0322	266NC0322	267NC0322	1/2"-13 NC	4	H3	3-3/8"	1-21/32"	27/64"
265NF0323	266NF0323	267NF0323	1/2"-20 NF	4	H3	3-3/8"	1-21/32"	29/64"
265NC0325	266NC0325	267NC0325	9/16"-12 NC	4	H3	3-19/32"	1-21/32"	31/64"
265NF0326	266NF0326	267NF0326	9/16"-18 NF	4	H3	3-19/32"	1-21/32"	33/64"
265NC0327	266NC0327	267NC0327	5/8"-11 NC	4	H3	3-13/16"	1-13/16"	17/32"
265NF0328	266NF0328	267NF0328	5/8"-18 NF	4	H3	3-13/16"	1-13/16"	37/64"
265NS0329	266NS0329	267NS0329	11/16"-11 NS	4	H3	4-1/32"	1-13/16"	19/32"
265NS0330	266NS0330	267NS0330	11/16"-16 NS	4	H3	4-1/32"	1-13/16"	5/8"
265NC0331	266NC0331	267NC0331	3/4"-10 NC	4	H3	4-1/4"	2"	21/32"
265NF0332	266NF0332	267NF0332	3/4"-16 NF	4	H3	4-1/4"	2"	11/16"
265NC0333	266NC0333	267NC0333	7/8"-9 NC	4	H4	4-11/16"	2-7/32"	49/64"
265NF0334	266NF0334	267NF0334	7/8"-14 NF	4	H4	4-11/16"	2-7/32"	13/16"
265NC0335	266NC0335	267NC0335	1"-8 NC	4	H4	5-1/8"	2-1/2"	7/8"
265NF0336	266NF0336	267NF0336	1"-12 NF	4	H4	5-1/8"	2-1/2"	59/64"
265NS0337	266NS0337	267NS0337	1"-14 NS	4	H4	5-1/8"	2-1/2"	15/16"

HSS Taps
 6 PC. PER PACK FROM
 4 - 40 → 5/8" - 18
 SOLD 1 PC. OVER 5/8" - 18

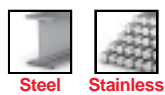

- ◆ Steel
- ◆ Stainless
- ◆ M2 HSS
- ◆ Ground Thread
- ◆ Heavy Duty



Steel Mild Cast Iron Aluminum
 Stainless

- ◆ M2 HSS
- ◆ Ground Thread
- ◆ Heavy Duty

Spiral Point Taps are ideal for machine tapping through holes or blind holes with adequate bottom clearance.

SOLD IN PACKS OF 6.



Spiral Point (Gun) Taps - M2 HSS

Part #	Size	No. Of Flutes	OAL	Thread Length	Drill Size
265SP0632	6-32	2	2"	11/16"	35
265SP0832	8-32	2	2-1/8"	3/4"	29
265SP1024	10-24	2	2-3/8"	7/8"	25
265SP1032	10-32	2	2-3/8"	7/8"	25
265SP1224	12-24	2	2-3/8"	15/16"	16
265SP1420	1/4"-20	2	2-1/2"	1"	7
265SP1428	1/4"-28	2	2-1/2"	1"	7
265SP5618	5/16"-18	2	2-23/32"	1-1/8"	F
265SP3816	3/8"-16	3	2-15/16"	1-1/4"	5/16"
265SP1312	1/2"-13	3	3-3/8"	1-21/32"	27/64"



Steel Mild Cast Iron Aluminum
 Stainless

- ◆ M2 HSS
- ◆ Ground Thread
- ◆ Heavy Duty



Made In

Spiral Point Taps are ideal for machine tapping through holes or blind holes with adequate bottom clearance.

SOLD IN PACKS OF 5.



Spiral Point (Gun) Taps - M2 HSS - Made in USA

Part #	Size	No. Of Flutes	OAL	Thread Length	Drill Size
GUN-0632	6-32	2	2"	11/16"	35
GUN-0832	8-32	2	2-1/8"	3/4"	29
GUN-1024	10-24	2	2-3/8"	7/8"	25
GUN-1032	10-32	2	2-3/8"	7/8"	25
GUN-1224	12-24	2	2-3/8"	15/16"	16
GUN-1420	1/4"-20	2	2-1/2"	1"	7
GUN-1428	1/4"-28	2	2-1/2"	1"	7
GUN-5618	5/16"-18	2	2-23/32"	1-1/8"	F
GUN-3816	3/8"-16	3	2-15/16"	1-1/4"	5/16"
GUN-1312	1/2"-13	3	3-3/8"	1-21/32"	27/64"
GUN-3410	3/4"-10	3	3-3/8"	1-21/32"	27/64"



Steel Mild Cast Iron Aluminum
 Stainless

- ◆ M2 HSS
- ◆ Ground Thread
- ◆ Heavy Duty

Drill and Tap holes in one operation, saving a complete setup!

SOLD IN PACKS OF 5.



Combo Drill Taps - M2 HSS

Part #	Thread Size	Drill Size	Thread Length	OAL
266TD0632	6-32	0.1095	11/16"	2"
266TD0832	8-32	0.1360	3/4"	2-1/8"
266TD0836	8-36	0.1360	3/4"	2-1/8"
266TD1024	10-24	0.1520	7/8"	2-3/8"
266TD1032	10-32	0.1520	7/8"	2-3/8"
266TD1224	12-24	0.1770	15/16"	2-3/8"
267TD1420	1/4"-20	0.2010	15/16"	2-1/2"
267TD1428	1/4"-28	0.2010	15/16"	2-1/2"
267TD5618	5/16"-18	0.2570	1-1/8"	3"
267TD3816	3/8"-16	0.3125	1-1/4"	3-1/2"
267TD3824	3/8"-24	0.3125	1-1/4"	3-1/2"
267TD7614	7/16"-14	0.3680	1-7/16"	3-7/8"
267TD1213	1/2"-13	0.4250	1-21/32"	4-1/4"



3 in 1 Combo Drill Taps - M2 HSS

Part #	Thread Size	Drill Size	Thread Length	OAL
HDT-0632	6-32	0.0787	9/64"	2-1/4"
HDT-0832	8-32	0.0984	5/32"	2-1/4"
HDT-1024	10-24	0.1181	13/64"	2-1/4"
HDT-1032	10-32	0.1181	5/32"	2-23/64"
HDT-1224	12-24	0.1181	13/64"	2-23/64"
HDT-1420	1/4"-20	0.1574	1/4"	2-37/64"
HDT-5618	5/16"-18	0.1574	29/64"	3"
HDT-3816	3/8"-16	0.1968	15/32"	3-3/16"
HDT-1213	1/2"-13	0.3419	27/64"	3-13/32"

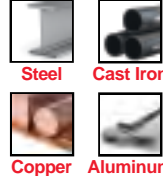

- ◆ 1/4" Hex Impact Shank
- ◆ M2 HSS
- ◆ Ground Thread
- ◆ Fast Spiral Flute
- ◆ Tri-Point Tip
- ◆ Retail Packaging
- ◆ Sold Individually



1. DRILLING



2. TAPPING



3. CHAMFER



IMPACT
1/4" HEX IMPACT SHANK



FAST SPIRAL FLUTE



IMPACT
1/4" HEX IMPACT SHANK



RETAIL PACKAGING

3 in 1 Combo Drill Taps - 8 Pc. Kit

Part #	Description	Sizes
HDT-SET8	8 Pc. 3 in 1 Drill Tap Kit	6-32 - 1/2"-13



6-32



12-24



8-32



1/4"-20



10-24



3/8"-16



10-32



1/2"-13



Tri-Point Tip



**NEW
PACKAGING**

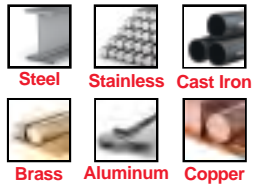

- ◆ Individually Blister Packaged
- ◆ Industrial Quality
- ◆ 5/8" - 11 SPINDLE



USE RED - NUT WIRE CUP ADAPTER IN CLOCKWISE ROTATION ONLY.



Industrial Wire Cups

Part #	Size	Description	Wire Type	Max RPM
KCC075	2-3/4"	Knotted Cup	.020 Carbon Steel	12,500
KCS075	2-3/4"	Knotted Cup	.020 Stainless Steel	12,500
KCC100	4"	Knotted Cup	.020 Carbon Steel	8,500
KCC150	6"	Knotted Cup	.020 Carbon Steel	6,500
CCC075	3"	Crimped Cup	.014 Carbon Steel	12,500
CCC100	4"	Crimped Cup	.014 Carbon Steel	8,500

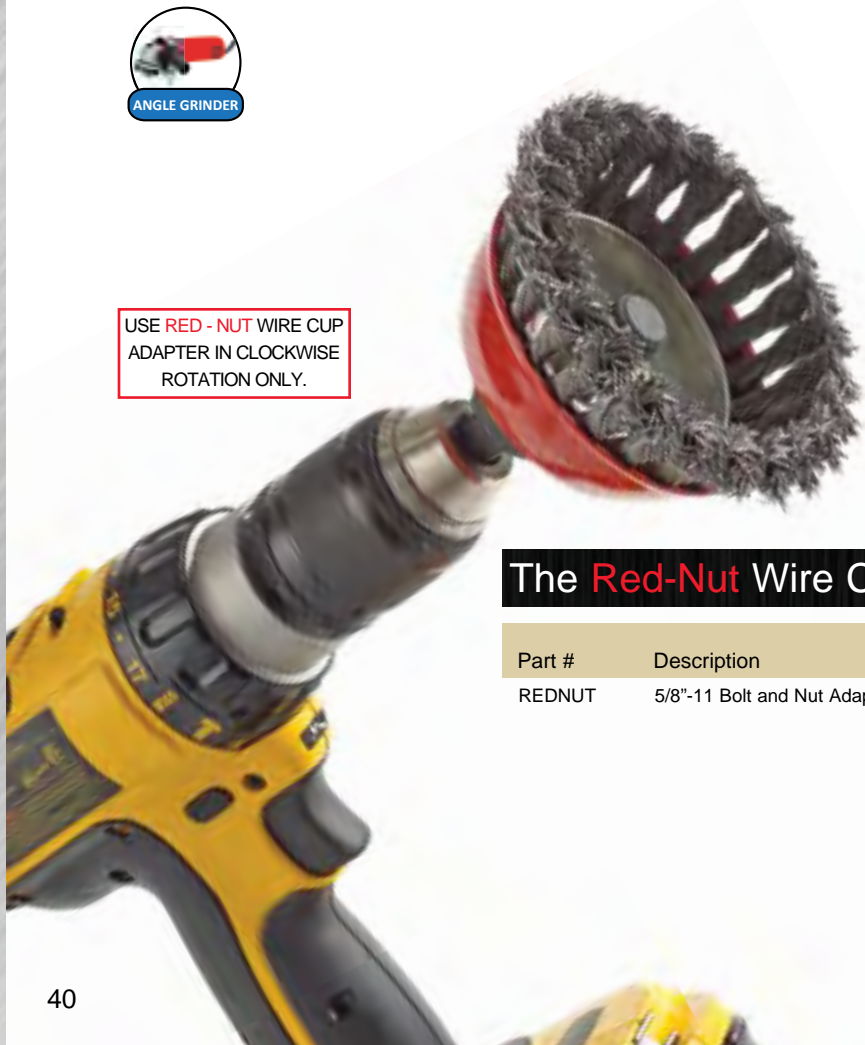

The Red-Nut Wire Cup Adapter

Part #	Description
REDNUT	5/8"-11 Bolt and Nut Adapter

- ◆ 3-Flat Shank
- ◆ For Use in 1/2" Handheld Drills
- ◆ Light Grinding





Stringer Bead Wheel

NEW PACKAGING



Industrial Wire Wheels

Part #	Size	Description	Wire Type	Max RPM
TKW100	4"	Twist Knot Wheel	.020 Carbon Steel	12,500
SBW100	4"	Stringer Bead Wheel	.020 Carbon Steel	12,500
SBS100	4"	Stringer Bead Wheel	.020 Stainless Steel	12,500
SBW175	7"	Stringer Bead Wheel	.020 Carbon Steel	9,000
WBB120	12"	Walk Behind Wire Brush	.035 Carbon Steel (1" Spindle)	3,600

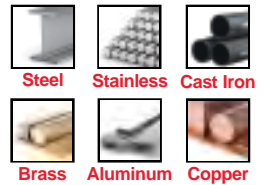

- ◆ Individually Blister Packaged
- ◆ Industrial Quality
- ◆ 5/8" - 11 SPINDLE

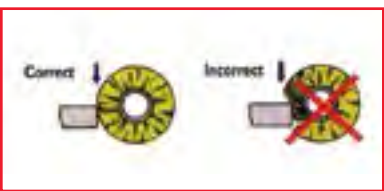

APPLICATION	KNOTTED CUP WIRE BRUSH	CRIMPED CUP WIRE BRUSH	TWIST KNOT WIRE BRUSH	STRINGER BEAD WIRE BRUSH
DEBURRING (FINE)	⊙	⊙		
DEBURRING (COURSE)			⊙	⊙
EDGE BLENDING	⊙	⊙		
WELD, SCALE REMOVAL			⊙	⊙
WELD PREP				⊙
SURFACE FINISHING	⊙	⊙		
RUST OXIDE (FINE)	⊙	⊙		
RUST OXIDE (COARSE)			⊙	⊙
PAINT REMOVAL	⊙	⊙		
ROUGHENING	⊙	⊙	⊙	⊙
CLEANING	⊙	⊙		⊙
FLASH REMOVAL		⊙	⊙	
TOOL MARK REMOVAL		⊙	⊙	
EXPANSION JOINT		⊙	⊙	





Cylinder

Part #	Dia.	Cut	Qty.
CBA-1	1/4"	5/8"	1
CBA-3	3/8"	3/4"	1
CBA-5	1/2"	1"	1
CBA-7	3/4"	1"	1

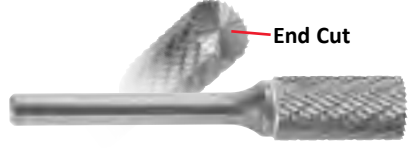

Cylinder w/ End Cut

Part #	Dia.	Cut	Qty.
CBB-1	1/4"	5/8"	1
CBB-3	3/8"	3/4"	1
CBB-5	1/2"	1"	1
CBB-7	3/4"	1"	1



Cylinder w/ Radius

Part #	Dia.	Cut	Qty.
CBC-1	1/4"	5/8"	1
CBC-3	3/8"	3/4"	1
CBC-5	1/2"	1"	1
CBC-6	5/8"	1"	1



Tree w/ Radius

Part #	Dia.	Cut	Qty.
CBF-1	1/4"	5/8"	1
CBF-3	3/8"	3/4"	1
CBF-5	1/2"	1"	1
CBF-6	5/8"	1"	1



Tree w/ Point

Part #	Dia.	Cut	Qty.
CBG-1	1/4"	5/8"	1
CBG-3	3/8"	3/4"	1
CBG-5	1/2"	1"	1



Flame

Part #	Dia.	Cut	Qty.
CBH-1	1/4"	1/2"	1
CBH-5	1/2"	1-1/4"	1



Ball

Part #	Dia.	Cut	Qty.
CBD-1	1/4"	1/4"	1
CBD-3	3/8"	3/8"	1
CBD-5	1/2"	1/2"	1



Oval

Part #	Dia.	Cut	Qty.
CBE-1	1/4"	3/8"	1
CBE-3	3/8"	5/8"	1
CBE-5	1/2"	7/8"	1
CBE-6	5/8"	1"	1



14° Taper w/ Radius

Part #	Dia.	Cut	Qty.
CBL-1	1/4"	5/8"	1
CBL-3	3/8"	1-1/16"	1
CBL-4	1/2"	1-1/8"	1
CBL-5	5/8"	1-3/16"	1
CBL-7	3/4"	1-1/2"	1



Pointed Cone

Part #	Dia.	Cut	Qty.
CBM-2	1/4"	3/4"	1
CBM-4	3/8"	5/8"	1
CBM-5	1/2"	7/8"	1



Inverted Cone

Part #	Dia.	Cut	Qty.
CBN-1	1/4"	5/16"	1
CBN-2	3/8"	3/8"	1
CBN-4	1/2"	1/2"	1



Cone 60°

Part #	Dia.	Cut	Qty.
CBJ-1	1/4"	3/16"	1
CBJ-3	3/8"	1/4"	1
CBJ-5	1/2"	7/16"	1



Cone 90°

Part #	Dia.	Cut	Qty.
CBK-1	1/4"	1/4"	1
CBK-3	3/8"	3/8"	1
CBK-5	1/2"	1/2"	1

Made In

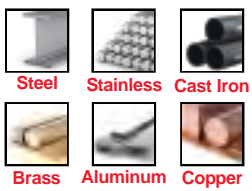

- ◆ Solid Carbide
- ◆ Bright Finish
- ◆ Sold Individually





Cylinder

Part #	Dia.	Cut	Qty.
SA-1NF	1/4"	3/4"	1
SA-3NF	3/8"	3/4"	1
SA-5NF	1/2"	1"	1
SA-6NF	5/8"	1"	1
SA-7NF	3/4"	1"	1



Ball

Part #	Dia.	Cut	Qty.
SD-1NF	1/4"	1/4"	1
SD-3NF	3/8"	3/8"	1
SD-5NF	1/2"	1/2"	1
SD-6NF	5/8"	5/8"	1
SD-7NF	3/4"	3/4"	1



Tree w/ Radius

Part #	Dia.	Cut	Qty.
SF-1NF	1/4"	3/4"	1
SF-3NF	3/8"	3/4"	1
SF-5NF	1/2"	1"	1
SF-6NF	5/8"	1"	1
SF-14NF	3/4"	1-1/4"	1



Cylinder w/ Radius

Part #	Dia.	Cut	Qty.
SC-1NF	1/4"	3/4"	1
SC-3NF	3/8"	3/4"	1
SC-5NF	1/2"	1"	1
SC-6NF	5/8"	1"	1
SC-7NF	3/4"	1"	1



Oval

Part #	Dia.	Cut	Qty.
SE-3NF	3/8"	5/8"	1
SE-5NF	1/2"	7/8"	1
SE-6NF	5/8"	1"	1
SE-7NF	3/4"	1"	1



14° Taper w/ Radius

Part #	Dia.	Cut	Qty.
SL-3NF	3/8"	1-1/16"	1
SL-4NF	1/2"	1-1/8"	1
SL-6NF	5/8"	1-5/16"	1
SL-7NF	3/4"	1-1/2"	1



METAL HUOT CASE

8 Pc. Carbide Burr Set

Part #	Description	Qty.
CB-8	8 Pc Ferrous Metal Set	1



Part#	Dia.	Cut
CBA-1	1/4"	5/8"
CBA-5	1/2"	1"



Part#	Dia.	Cut
CBC-3	3/8"	3/4"
CBC-5	1/2"	1"



Part#	Dia.	Cut
CBD-1	1/4"	1/4"
CBD-5	1/2"	1/2"



Part#	Dia.	Cut
CBF-3	3/8"	3/4"
CBF-5	1/2"	1"



Made In



- ◆ Solid Carbide
- ◆ Deep Flute
- ◆ Bright Finish
- ◆ Sold Individually



DIE GRINDER

Non-Ferrous (Soft Metals)



Brass



Aluminum



Copper



Plastics



- ◆ Solid Carbide
- ◆ Bright Finish

Made In



SOLID CARBIDE BURS

1/8"
5/32"
3/16"
7/32"
1/4"
9/32"
5/16"
11/32"
3/8"
13/32"
7/16"
15/32"
1/2"

274MC0001
13 Steps 1/8" - 1/2"

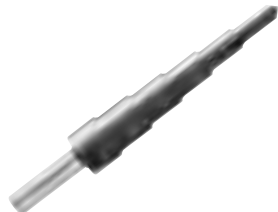

3/16"
1/4"
5/16"
3/8"
7/16"
1/2"

274MC0002
6 Steps 3/16" - 1/2"



1/4"
5/16"
3/8"
7/16"
1/2"
9/16"
5/8"
11/16"
3/4"

274MC0003
9 Steps 1/4" - 3/4"

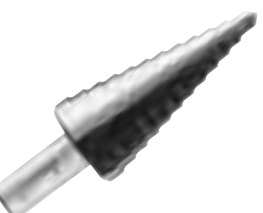

3/16"
1/4"
5/16"
3/8"
7/16"
1/2"
9/16"
5/8"
11/16"
3/4"
13/16"
7/8"

274MC0004
12 Steps 3/16" - 7/8"



7/16"
1/2"
9/16"
5/8"
11/16"
3/4"
13/16"
7/8"
15/16"
1"
1-1/16"
1-1/8"

274MC0005
12 Steps 7/16" - 1-1/8"

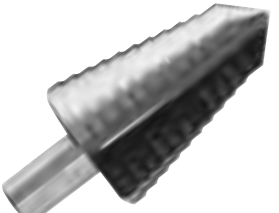

3/4"
13/16"
7/8"
15/16"
1"
1-1/16"
1-1/8"
1-3/16"
1-1/4"
1-5/16"
1-3/8"

274MC0006
11 Steps 3/4" - 1-3/8"



3/8"
7/16"
3/4"

For drilling 3 standard size holes to accommodate drive screws for knockout punches.

274MC0007
3 Steps 3/8" - 3/4"

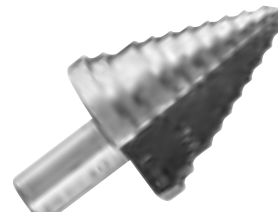

7/8"
1-1/8"

7/8" hole for 1/2" conduit.
1-1/8" hole for 3/4" conduit.

274MC0008
2 Steps 7/8" - 1-1/8"

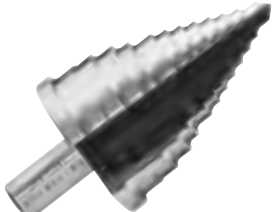

7/8"
1-1/8"
1-7/32"
1-1/4"
1-3/8"

1-7/32" hole for oil tight switches.

274MC0009
5 Steps 7/8" - 1-3/8"

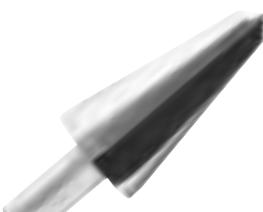

7/8"

274MC0010
1 Cone 7/8"
List \$65.53

ENHANCED FAST SPIRAL

NEW!



3/16"
1/4"
3/8"
1/2"
5/8"
3/4"
7/8"
1"
1-1/8"
1-1/4"
1-3/8"

3/8" HEX Shank
3/16" Drilling Depth

274MC0011

ENHANCED THE BIG 11
One Size Fits All



- ◆ M2 HSS
- ◆ Lobbed 3/8" Non-Slip Shank
- ◆ Drill 1/8" Thick
- ◆ Double Flute
- ◆ Bright Finish



STEP DRILLS ARE SOLD INDIVIDUALLY.

More accurate control of hole size in various sheet materials up to 1/8" thick. Each step bit drills a range of sizes. The further the bit advances, the larger the diameter of the hole gets. Because step drill bits enter the material one step at a time, the operator can drill the desired hole by counting the individual steps, or by using a washer as a simple stop. The self starting tip eliminates the need for pilot holes. Applications include junction boxes, switch boxes, metal studs, electrical applications, lighting fixtures, auto body work, and many other uses.

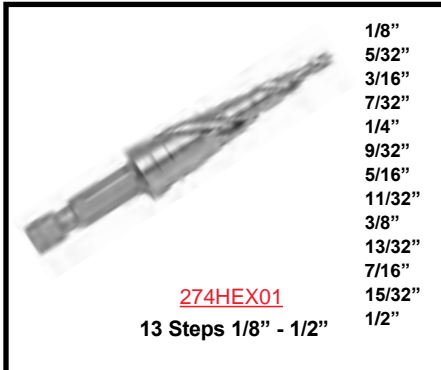

274HEX01
13 Steps 1/8" - 1/2"

1/8"
5/32"
3/16"
7/32"
1/4"
9/32"
5/16"
11/32"
3/8"
13/32"
7/16"
15/32"
1/2"

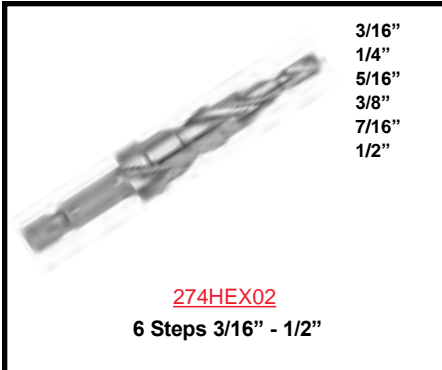

274HEX02
6 Steps 3/16" - 1/2"

3/16"
1/4"
5/16"
3/8"
7/16"
1/2"

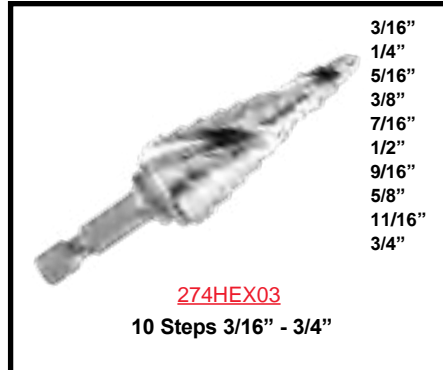

274HEX03
10 Steps 3/16" - 3/4"

3/16"
1/4"
5/16"
3/8"
7/16"
1/2"
9/16"
5/8"
11/16"
3/4"

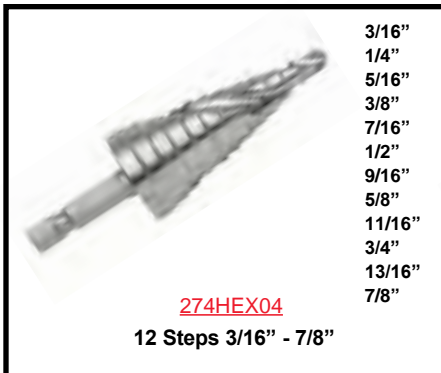

274HEX04
12 Steps 3/16" - 7/8"

3/16"
1/4"
5/16"
3/8"
7/16"
1/2"
9/16"
5/8"
11/16"
3/4"
13/16"
7/8"

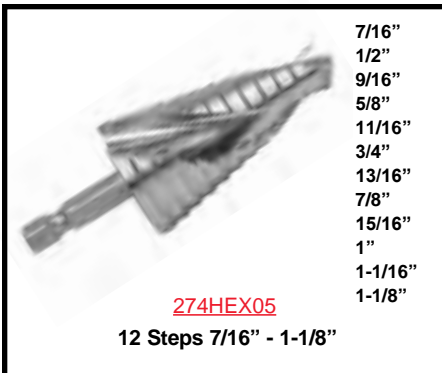

274HEX05
12 Steps 7/16" - 1-1/8"

7/16"
1/2"
9/16"
5/8"
11/16"
3/4"
13/16"
7/8"
15/16"
1"
1-1/16"
1-1/8"

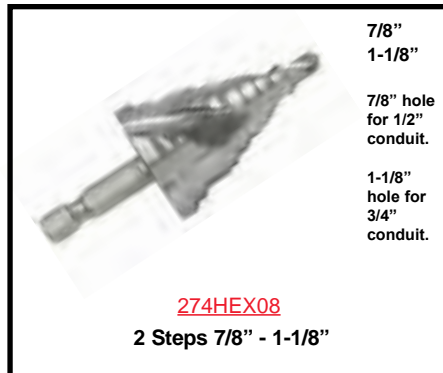

274HEX08
2 Steps 7/8" - 1-1/8"

7/8"
1-1/8"

7/8" hole for 1/2" conduit.

1-1/8" hole for 3/4" conduit.

M2 HSS FAST SPIRAL STEP DRILL



- ◆ 1/4" Hex Impact Shank
- ◆ M2 HSS
- ◆ Fast Spiral Flutes
- ◆ Jam Free Performance
- ◆ Self Starting Split Point
- ◆ Bright Finish
- ◆ Sold Individually





3-FLAT SHANK

Reamer - CAR / Construction - Spiral Flute - HSS

Part #	Size	Point Diameter	OAL	Flute	Shank	Type
CRF-2464	3/8"	0.250	5"	4"	3/8"	3-Flat Car / Constr.
CRF-2864	7/16"	0.281	5-1/4"	4"	7/16"	3-Flat Car / Constr.
CRF-3264	1/2"	0.343	6"	4-1/2"	1/2"	3-Flat Car / Constr.
CRF-3664	9/16"	0.343	6-1/4"	4-1/2"	1/2"	3-Flat Car / Constr.
CRF-4064	5/8"	0.343	6-1/2"	4-1/2"	1/2"	3-Flat Car / Constr.
CRF-4464	11/16"	0.375	7"	4-1/2"	1/2"	3-Flat Car / Constr.
CRF-4864	3/4"	0.406	7-1/4"	5"	1/2"	3-Flat Car / Constr.
CRF-5264	13/16"	0.468	7-1/4"	5"	1/2"	3-Flat Car / Constr.
CRF-5664	7/8"	0.500	7-1/4"	5"	1/2"	3-Flat Car / Constr.
CRF-6064	15/16"	0.585	7-1/4"	5"	1/2"	3-Flat Car / Constr.
CRF-6464	1"	0.594	7-1/4"	5"	1/2"	3-Flat Car / Constr.
CRF-6864	1-1/16"	0.807	7-1/4"	5"	1/2"	3-Flat Car / Constr.

BLACK Oxide



- ◆ M2 HSS
- ◆ Tapered Point
- ◆ Left-Hand Spiral
- ◆ Right-Hand Cut
- ◆ 3-Flat Shank
- ◆ Made in Europe
- ◆ Sold Individually



Reaming Steel For Aligning Existing Holes & Bolt / Rivet Installation



3-FLAT SHANK

Reamer - CAR / Construction - *Fast Spiral* - HSS

Part #	Size	Point Diameter	OAL	Flute	Shank	Type
CFF-2464	3/8"	0.250	5"	4"	3/8"	3-Flat Car / Constr.
CFF-3264	1/2"	0.343	6"	4-1/2"	1/2"	3-Flat Car / Constr.
CFF-3664	9/16"	0.343	6-1/4"	4-1/2"	1/2"	3-Flat Car / Constr.
CFF-4064	5/8"	0.343	6-1/2"	4-1/2"	1/2"	3-Flat Car / Constr.
CFF-4464	11/16"	0.375	7"	4-1/2"	1/2"	3-Flat Car / Constr.
CFF-4864	3/4"	0.406	7-1/4"	5"	1/2"	3-Flat Car / Constr.
CFF-5264	13/16"	0.468	7-1/4"	5"	1/2"	3-Flat Car / Constr.
CFF-5664	7/8"	0.500	7-1/4"	5"	1/2"	3-Flat Car / Constr.
CFF-6064	15/16"	0.585	7-1/4"	5"	1/2"	3-Flat Car / Constr.
CFF-6464	1"	0.594	7-1/4"	5"	1/2"	3-Flat Car / Constr.
CFF-8064	1-1/4"	0.719	7-1/4"	5"	1/2"	3-Flat Car / Constr.

BLACK Oxide



- ◆ M2 HSS
- ◆ Tapered Point
- ◆ Left-Hand Spiral
- ◆ Right-Hand Cut
- ◆ 3-Flat Shank
- ◆ Made in Europe
- ◆ Sold Individually





Reamer - CAR / Construction - Spiral Flute - HEX - HSS

Part #	Size	Point Diameter	OAL	Flute	Shank	Type
CHX-4464	11/16"	0.375	6-3/8"	4-1/2"	1-1/16"	HEX Car
CHX-5264	13/16"	0.468	7"	5"	1-1/4"	HEX Car
CHX-6064	15/16"	0.585	7"	5"	1-7/16"	HEX Car
CHX-6864	1-1/16"	0.807	7"	5"	1-5/8"	HEX Car

BLACK Oxide



- ◆ M2 HSS
- ◆ Tapered Point
- ◆ Left-Hand Spiral
- ◆ Right-Hand Cut
- ◆ HEX Nut Shank
- ◆ Made in Europe
- ◆ Sold Individually



Reamer - BRIDGE - Spiral Flute - HEX - HSS

Part #	Size	Point Diameter	OAL	Flute	Shank	Type
CBB-4464	11/16"	0.375	9-1/4"	7-1/8"	1-1/16"	HEX Bridge
CBB-5264	13/16"	0.468	9-3/8"	7-3/8"	1-1/4"	HEX Bridge
CBB-6064	15/16"	0.585	9-3/8"	7-3/8"	1-7/16"	HEX Bridge
CBB-6864	1-1/16"	0.807	9-3/8"	7-3/8"	1-5/8"	HEX Bridge

BLACK Oxide



- ◆ M2 HSS
- ◆ Tapered Point
- ◆ Left-Hand Spiral
- ◆ Right-Hand Cut
- ◆ HEX Nut Shank
- ◆ Made in Europe
- ◆ Sold Individually



Reaming Steel For Aligning Existing Holes & Bolt / Rivet Installation



Bridge Construction



Ship Building



Structural Steel Erection



Reaming Steel For Aligning Existing Holes & Bolt / Rivet Installation

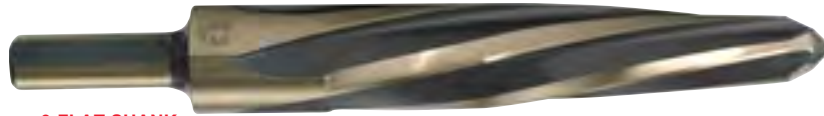

3-FLAT SHANK

Reamer - CAR / Construction - Spiral Flute - HSS

Part #	Size	Point Diameter	OAL	Flute	Shank	Type
ASF-2464	3/8"	0.250	5"	4"	3/8"	3-Flat Car / Constr.
ASF-3264	1/2"	0.281	6"	4-1/2"	1/2"	3-Flat Car / Constr.
ASF-3664	9/16"	0.343	6-1/4"	4-1/2"	1/2"	3-Flat Car / Constr.
ASF-4064	5/8"	0.343	6-1/2"	4-1/2"	1/2"	3-Flat Car / Constr.
ASF-4464	11/16"	0.375	7"	4-1/2"	1/2"	3-Flat Car / Constr.
ASF-4864	3/4"	0.406	7-1/4"	5"	1/2"	3-Flat Car / Constr.
ASF-5264	13/16"	0.468	7-1/4"	5"	1/2"	3-Flat Car / Constr.
ASF-5664	7/8"	0.500	7-1/4"	5"	1/2"	3-Flat Car / Constr.
ASF-6064	15/16"	0.585	7-1/4"	5"	1/2"	3-Flat Car / Constr.
ASF-6464	1"	0.594	7-1/4"	5"	1/2"	3-Flat Car / Constr.
ASF-8064	1-1/4"	0.719	7-1/4"	5"	1/2"	3-Flat Car / Constr.

Black & Gold



- ◆ M2 HSS
- ◆ Tapered Point
- ◆ Left-Hand Spiral
- ◆ Right-Hand Cut
- ◆ 3-Flat Shank
- ◆ Sold Individually



Black & Gold



- ◆ M2 HSS
- ◆ Tapered Point
- ◆ Left-Hand Spiral
- ◆ Right-Hand Cut
- ◆ 3-Flat Shank
- ◆ Sold Individually



3-FLAT SHANK

Reamer - CAR / Construction - *Fast Spiral* - HSS

Part #	Size	Point Diameter	OAL	Flute	Shank	Type
AFC-2464	3/8"	0.250	5"	4"	3/8"	3-Flat Car / Constr.
AFC-3264	1/2"	0.281	6"	4-1/2"	1/2"	3-Flat Car / Constr.
AFC-3664	9/16"	0.343	6-1/4"	4-1/2"	1/2"	3-Flat Car / Constr.
AFC-4064	5/8"	0.343	6-1/2"	4-1/2"	1/2"	3-Flat Car / Constr.
AFC-4464	11/16"	0.375	7"	4-1/2"	1/2"	3-Flat Car / Constr.
AFC-4864	3/4"	0.406	7-1/4"	5"	1/2"	3-Flat Car / Constr.
AFC-5264	13/16"	0.468	7-1/4"	5"	1/2"	3-Flat Car / Constr.
AFC-5664	7/8"	0.500	7-1/4"	5"	1/2"	3-Flat Car / Constr.
AFC-6064	15/16"	0.585	7-1/4"	5"	1/2"	3-Flat Car / Constr.
AFC-6464	1"	0.594	7-1/4"	5"	1/2"	3-Flat Car / Constr.
AFC-8064	1-1/4"	0.719	7-1/4"	5"	1/2"	3-Flat Car / Constr.

Black & Gold



- ◆ M2 HSS
- ◆ Tapered Point
- ◆ Left-Hand Spiral
- ◆ Right-Hand Cut
- ◆ HEX Nut Shank
- ◆ Sold Individually

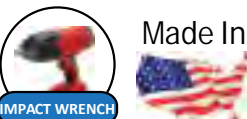

Reamer - CAR - Spiral Flute - **HEX** - HSS

Part #	Size	Point Diameter	OAL	Flute	Shank	Type
ACX-4464	11/16"	0.375	6-3/8"	4-1/2"	1-1/16"	HEX Car
ACX-5264	13/16"	0.468	7"	5"	1-1/4"	HEX Car
ACX-6064	15/16"	0.585	7"	5"	1-7/16"	HEX Car
ACX-6864	1-1/16"	0.807	7"	5"	1-5/8"	HEX Car



Black & Gold VIP-STEP Jobber Drills - M2 HSS

Part #	Size	Dec.	OAL	Flute	Qty.	Part #	Size	Dec.	OAL	Flute	Qty.
VIP-1264	3/16"	.1875	3-1/2"	2-5/16"	12	VIP-2064	5/16"	.3125	4-1/2"	3-3/16"	12
VIP-1464	7/32"	.2188	3-3/4"	2-1/2"	12	VIP-2264	11/32"	.3438	4-3/4"	3-7/16"	6
VIP-1664	1/4"	.2500	4"	2-3/4"	12	VIP-2464	3/8"	.3750	5"	3-5/8"	6
VIP-1864	9/32"	.2812	4-1/4"	2-15/16"	12	VIP-2864	7/16"	.4375	5-1/2"	4-1/16"	6
						VIP-3264	1/2"	.5000	6"	4-1/2"	6

Black & Gold



- ◆ Jobber Length
- ◆ 135° Step Point
- ◆ Ground Flute
- ◆ 3-Flat Shank
- ◆ Heavy Duty Web
- ◆ M2 HSS



3X SPEED

- **Fast**
- **Clean**
- **Precise**
- **Bur Free**

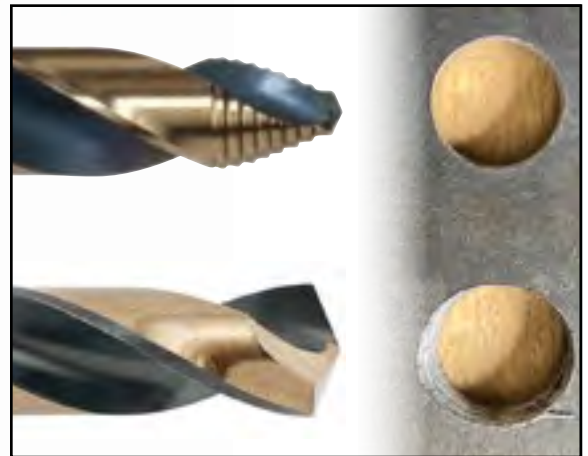



Steel Stainless Cast Iron

- ◆ M2 HSS
- ◆ 3/4" Weldon Shanks
- ◆ For Small Diameters
- ◆ Aggressive Cutting Edges
- ◆ No Center Punch Required
- ◆ Cut up to 2"
- ◆ For All Magnetic Drills
- ◆ Sold Individually

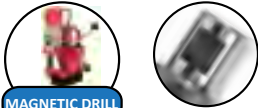

MAGNETIC DRILL 3/4" Weldon Shank

Use Cutting Oil



1" Cutting Depth

1" HSS Annular Twist Drill

Part #	Size	Depth
100DR1664	1/4"	1"
100DR2064	5/16"	1"
100DR2464	3/8"	1"
100DR2864	7/16"	1"
100DR3264	1/2"	1"

ANNULAR TWIST DRILL M2 HSS



2" Cutting Depth

2" HSS Annular Twist Drill

Part #	Size	Depth
200DR1664	1/4"	2"
200DR2064	5/16"	2"
200DR2464	3/8"	2"
200DR2864	7/16"	2"
200DR3264	1/2"	2"



Steel Stainless Cast Iron

- ◆ M2 HSS
- ◆ 3/4" Weldon Shanks
- ◆ Aggressive Cutting Edges
- ◆ No Center Punch Required
- ◆ Cut up to 2"
- ◆ For All Magnetic Drills
- ◆ Sold Individually

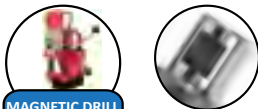

MAGNETIC DRILL 3/4" Weldon Shank

Use Cutting Oil

Annular Cutter Kit - 6 Pc.

Part #	Description
100MC-SET1	1" Cutting Depth
200MC-SET1	2" Cutting Depth

Each Set Include the Diameters:
 1/2" • 9/16" • 5/8" • 3/4" • 13/16" • 7/8"

ANNULAR CUTTER M2 HSS



6 H.S.S. Annular Cutters + **2** Pilot Pins



1" Cutting Depth

1" HSS Annular Cutter

Part #	Size	Depth	Pin
100MC2864	7/16"	1"	SS-1
100MC3264	1/2"	1"	SS-2
100MC3664	9/16"	1"	SS-3
100MC4064	5/8"	1"	SS-3
100MC4464	11/16"	1"	SS-3
100MC4864	3/4"	1"	SS-3
100MC5264	13/16"	1"	SS-3
100MC5664	7/8"	1"	SS-3
100MC6064	15/16"	1"	SS-3
100MC6464	1"	1"	SS-3
100MC6864	1-1/16"	1"	SS-3
100MC7264	1-1/8"	1"	SS-3
100MC7664	1-3/16"	1"	SS-3
100MC8064	1-1/4"	1"	SS-3
100MC8464	1-5/16"	1"	SS-3
100MC8864	1-3/8"	1"	SS-3
100MC9264	1-7/16"	1"	SS-3
100MC9664	1-1/2"	1"	SS-3
100MC1916	1-9/16"	1"	SS-3
100MC1058	1-5/8"	1"	SS-3
100MC1116	1-11/16"	1"	SS-3
100MC1034	1-3/4"	1"	SS-3
100MC1316	1-13/16"	1"	SS-3
100MC1078	1-7/8"	1"	SS-3
100MC1516	1-15/16"	1"	SS-3
100MC2002	2"	1"	SS-3
100MC2116	2-1/16"	1"	SS-3



2" Cutting Depth

2" HSS Annular Cutter

Part #	Size	Depth	Pin
200MC2864	7/16"	2"	LL-1
200MC3264	1/2"	2"	LL-2
200MC3664	9/16"	2"	LL-3
200MC4064	5/8"	2"	LL-3
200MC4464	11/16"	2"	LL-3
200MC4864	3/4"	2"	LL-3
200MC5264	13/16"	2"	LL-3
200MC5664	7/8"	2"	LL-3
200MC6064	15/16"	2"	LL-3
200MC6464	1"	2"	LL-3
200MC6864	1-1/16"	2"	LL-3
200MC7264	1-1/8"	2"	LL-3
200MC7664	1-3/16"	2"	LL-3
200MC8064	1-1/4"	2"	LL-3
200MC8464	1-5/16"	2"	LL-3
200MC8864	1-3/8"	2"	LL-3
200MC9264	1-7/16"	2"	LL-3
200MC9664	1-1/2"	2"	LL-3
200MC1916	1-9/16"	2"	LL-3
200MC1058	1-5/8"	2"	LL-3
200MC1116	1-11/16"	2"	LL-3
200MC1034	1-3/4"	2"	LL-3
200MC1316	1-13/16"	2"	LL-3
200MC1078	1-7/8"	2"	LL-3
200MC1516	1-15/16"	2"	LL-3
200MC2002	2"	2"	LL-3
200MC2116	2-1/16"	2"	LL-3



Steel



Stainless Cast Iron

- ◆ M2 HSS
- ◆ 3/4" Weldon Shanks
- ◆ Aggressive Cutting Edges
- ◆ No Center Punch Required
- ◆ Cut up to 2"
- ◆ For All Magnetic Drills
- ◆ Sold Individually

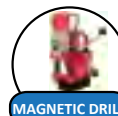

MAGNETIC DRILL



3/4" Weldon Shank



Use Cutting Oil



Allows overlap cut on existing holes

TCT – Carbide Tipped Annular Cutters Available. Please call.



Pilot Pins - 1" Cutter

Part #	Description
SS-1	1" Pilot Pin (for 7/16" x 1")
SS-2	1" Pilot Pin (for 1/2" x 1")
SS-3	1" Pilot Pin (for 9/16" x 1" +)



Pilot Pins - 2" Cutter

Part #	Description
LL-1	2" Pilot Pin (for 7/16" x 2")
LL-2	2" Pilot Pin (for 1/2" x 2")
LL-3	2" Pilot Pin (for 9/16" x 2" +)

ANNULAR CUTTER
M2 HSS

NEW!



Steel Stainless Cast Iron

- ◆ Titanium Coating
- ◆ 3/4" Weldon Shanks
- ◆ Aggressive Cutting Edges
- ◆ For All Magnetic Drills
- ◆ Sold Individually

TITANIUM-M2 HSS COUNTERSINK

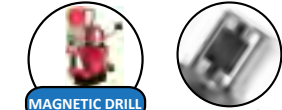

MAGNETIC DRILL 3/4" Weldon Shank

Use Cutting Oil

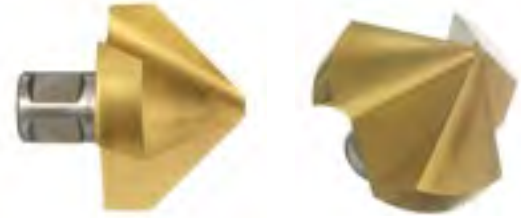

Titanium Countersink - 3 FLUTE

Part #	Angle	Range
SCS-82	82°	5/16" - 2-1/8"
SCS-90	90°	5/16" - 2-1/8"

NEW!



Steel Stainless Cast Iron

- ◆ Precise Tapping
- ◆ 3/4" Weldon Shanks
- ◆ Aggressive Cutting Edges
- ◆ For All Magnetic Drills
- ◆ Sold Individually

M2 HSS TAP

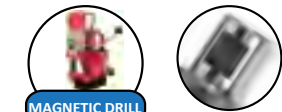

MAGNETIC DRILL 3/4" Weldon Shank

Use Cutting Oil



Tap - M2 HSS

Part #	Thread Size
TAP-1213	1/2" - 13 TAP
TAP-5811	5/8" - 11 TAP
TAP-3410	3/4" - 10 TAP
TAP-7809	7/8" - 9 TAP
TAP-1008	1" - 8 TAP

NEW!



Steel Stainless Cast Iron

- ◆ Drill and Tap At The Same Time
- ◆ 3/4" Weldon Shanks
- ◆ Aggressive Cutting Edge
- ◆ For All Magnetic Drills
- ◆ Sold Individually

M2 HSS DRILL TAP

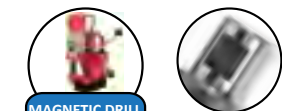

MAGNETIC DRILL 3/4" Weldon Shank

Use Cutting Oil



Drill Tap - M2 HSS

Part #	Thread Size
DRL-1213	1/2" - 13 DRILL TAP
DRL-5811	5/8" - 11 DRILL TAP
DRL-3410	3/4" - 10 DRILL TAP
DRL-7809	7/8" - 9 DRILL TAP
DRL-1008	1" - 8 DRILL TAP

NEW!



MAGNETIC CHIP COLLECTOR

EASY CLEAN UP OF METAL CHIPS & SHAVINGS

Magnetic Chip Collector

Part #	Description
MAG-BAT	Magnetic Chip Collector



1.



2.



3.



Mag Drill 1/2" Chuck Adapter

Part #	Description
MAG-CHUCK	1/2" Chuck with Key

- ◆ Fits Any 3/4" Weldon Shank Mag Drill
- ◆ Use With 1/2" Drill Accessories
- ◆ Sold Individually



5/16", 3/8", 7/16", 1/2", 9/16"



9/16", 5/8", 11/16", 3/4", 13/16"



13/16", 7/8", 15/16", 1", 1-1/16"

Step Reamer - Individual

Part #	Description	Depth	Qty.
STR-1	5 Step - 5/16" to 9/16"	1/2"	1
STR-2	5 Step - 9/16" to 13/16"	1/2"	1
STR-3	5 Step - 13/16" to 1-1/16"	1/2"	1



- ◆ M2 HSS
- ◆ 1/2" Cutting Depth
- ◆ Double Flute
- ◆ Black Oxide Coating
- ◆ 3/8" - 3-Flat Shank
- ◆ Sold Individually



Step Reamer - 3 Pc. Kit

Part #	Description	Depth	Qty.
STR-SET3	3 Pc. Kit with Case	1/2"	1



For Enlarging Holes in Steel Plate up to 1/2" Thick!



3/16" Cutting Depth



1/2" Cutting Depth

T.C.T. Hole Cutter

Part #	Size	Depth	Shank
HF0012	5/8"	3/16"	3/8"
HF0013	11/16"	3/16"	3/8"
HF0014	3/4"	3/16"	3/8"
HF0015	13/16"	3/16"	3/8"
HF0016	7/8"	3/16"	3/8"
HF0017	15/16"	3/16"	3/8"
HF0018	1"	3/16"	3/8"
HF0119	1-1/16"	3/16"	3/8"
HF0019	1-1/8"	3/16"	3/8"
HF0021	1-1/4"	3/16"	3/8"
HF0023	1-3/8"	3/16"	3/8"
HF0024	1-1/2"	3/16"	3/8"
HF0025	1-5/8"	3/16"	3/8"
HF0026	1-3/4"	3/16"	3/8"
HF0027	1-7/8"	3/16"	3/8"
HF0028	2"	3/16"	3/8"
HF0029	2-1/8"	3/16"	3/8"
HF0030	2-1/4"	3/16"	3/8"
HF0032	2-3/8"	3/16"	3/8"
HF0033	2-1/2"	3/16"	1/2"
HF0135	2-3/4"	3/16"	1/2"
HF0035	3"	3/16"	1/2"
HF0138	3-1/4"	3/16"	1/2"
HF0036	3-1/2"	3/16"	1/2"
HF0140	3-5/8"	3/16"	1/2"
HF0037	4"	3/16"	1/2"

T.C.T. Hole Cutter

Part #	Size	Depth	Shank
HG0011	9/16"	1/2"	3/8"
HG0012	5/8"	1/2"	3/8"
HG0013	11/16"	1/2"	3/8"
HG0014	3/4"	1/2"	3/8"
HG0015	13/16"	1/2"	3/8"
HG0016	7/8"	1/2"	3/8"
HG0017	15/16"	1/2"	3/8"
HG0018	1"	1/2"	3/8"
HG0119	1-1/16"	1/2"	3/8"
HG0019	1-1/8"	1/2"	3/8"
HG0020	1-3/16"	1/2"	3/8"
HG0021	1-1/4"	1/2"	3/8"
HG0023	1-3/8"	1/2"	3/8"
HG0024	1-1/2"	1/2"	3/8"
HG0025	1-5/8"	1/2"	3/8"
HG0026	1-3/4"	1/2"	3/8"
HG0027	1-7/8"	1/2"	3/8"
HG0028	2"	1/2"	3/8"
HG0029	2-1/8"	1/2"	3/8"
HG0030	2-1/4"	1/2"	3/8"
HG0032	2-3/8"	1/2"	3/8"
HG0033	2-1/2"	1/2"	1/2"
HG0135	2-3/4"	1/2"	1/2"
HG0035	3"	1/2"	1/2"
HG0138	3-1/4"	1/2"	1/2"
HG0036	3-1/2"	1/2"	1/2"
HG0037*	4"	1/2"	1/2"
HG0040*	4-1/2"	1/2"	1/2"
HG0050*	5"	1/2"	1/2"

* Use Pilot Part# HG-PILOT2



- ◆ Excellent Wear and Heat Resistance
- ◆ Tungsten Carbide Teeth
- ◆ Cuts Stainless Steel and Tough Alloys
- ◆ Ejects the Slug Saving Time
- ◆ Works in 3/8" & 1/2" Chucks
- ◆ Made In Taiwan



T.C.T. HOLE CUTTERS ARE SOLD INDIVIDUALLY.

- **Cut Faster**
- **Cut Cleaner**
- **Lasts Longer**

TUNGSTEN CARBIDE TEETH

Size	Steel (rpm)	Stainless Steel (rpm)
9/16" to 13/16"	700-1000	300-700
7/8" to 1-3/16"	500-800	200-450
1-1/4" to 1-9/16"	300-600	175-315
1-5/8" to 2"	200-500	120-225
2-1/16" to 2-3/8"	200-400	95-195
2-7/16" to 3"	150-300	80-150
3-1/16" to 5"	100-200	60-120



1-3/8" Cutting Depth

T.C.T. Hole Cutter

Part #	Size	Depth	Shank
HM0011	9/16"	1-3/8"	1/2"
HM0012	5/8"	1-3/8"	1/2"
HM0013	11/16"	1-3/8"	1/2"
HM0014	3/4"	1-3/8"	1/2"
HM0015	13/16"	1-3/8"	1/2"
HM0016	7/8"	1-3/8"	1/2"
HM0017	15/16"	1-3/8"	1/2"
HM0018	1"	1-3/8"	1/2"
HM0119	1-1/16"	1-3/8"	1/2"
HM0019	1-1/8"	1-3/8"	1/2"
HM0020	1-3/16"	1-3/8"	1/2"
HM0021	1-1/4"	1-3/8"	1/2"
HM0023	1-3/8"	1-3/8"	1/2"
HM0024	1-1/2"	1-3/8"	1/2"
HM0025	1-5/8"	1-3/8"	1/2"
HM0026	1-3/4"	1-3/8"	1/2"
HM0027	1-7/8"	1-3/8"	1/2"
HM0028	2"	1-3/8"	1/2"
HM0029	2-1/8"	1-3/8"	1/2"
HM0030	2-1/4"	1-3/8"	1/2"
HM0032	2-3/8"	1-3/8"	1/2"
HM0033	2-1/2"	1-3/8"	1/2"



- ◆ Excellent Wear and Heat Resistance
- ◆ Tungsten Carbide Teeth
- ◆ Cuts Stainless Steel and Tough Alloys
- ◆ Works in 1/2" Chucks
- ◆ Made In Taiwan



1/2" DRILL

T.C.T. HOLE CUTTERS ARE SOLD INDIVIDUALLY.

POW!

SHEET METAL
STEEL PLATE
STAINLESS STEEL

FOR USE IN 1/2" CHUCK DRILLS



2" Cutting Depth

T.C.T. Steel Door Hole Cutter

Part #	Size	Cut	Shank
HP0014	3/4"	2"	1/2"
HP0018	1"	2"	1/2"
HP0021	1-1/4"	2"	1/2"
HP0029	2-1/8"	2"	1/2"

- ◆ Made for Door Knob and Lock Installation
- ◆ Tungsten Carbide Teeth
- ◆ Works in 1/2" Chucks
- ◆ Made In Taiwan



Replacement Parts

Part #	Description
HF-PILOT	CENTER DRILL φ6mm x 50L
HF-S	SPRING 1.2MM X 16L
HG-PILOT	CENTER DRILL φ6mm x 60L
HG-PILOT2	CENTER DRILL φ8mm x 60L
HG-S	SPRING 1.2MM X 23L
HM-PILOT	CENTER DRILL φ6mm x 75L
HM-S	SPRING 1.2MM X 50L
HP-PILOT	CENTER DRILL φ6mm x 90L
HP-S	SPRING 1.2MM X 60L



BI-METAL

**PART # 275AV02E
ELECTRICIAN'S HOLE SAW KIT**

8 Pc. Set contains:
1 each 7/8" - 1-1/8" - 1-3/8" - 1-3/4" - 2" - 2-1/2"
2 Arbors - ARB-2 - ARB-5



BI-METAL

**PART # 275AV100
MAINTENANCE HOLE SAW KIT**

11 Pc. Set contains:
1 each 3/4" - 7/8" - 1-1/8" - 1-3/8" - 1-1/2"
1-3/4" - 2" - 2-1/4" - 2-1/2"
2 Arbors - ARB-2 - ARB-5



CARBIDE TIPPED

**PART # 275AT100
CARBIDE TIPPED
MAINTENANCE HOLE SAW KIT**

11 Pc. Set contains:
1 each 3/4" - 7/8" - 1-1/8" - 1-3/8" - 1-1/2"
1-3/4" - 2" - 2-1/4" - 2-1/2"
2 Arbors - ARB-2 - ARB-5



BI-METAL

**PART # 275AV08E
MASTER ELECTRICIAN'S HOLE
SAW KIT**

12 Pc. Set contains:
1 each 7/8" - 1-1/8" - 1-3/8" - 1-3/4" - 2" - 2-1/2"
3" - 3-5/8" - 4-1/8" - 4-1/2"
2 Arbors - ARB-2 - ARB-5



Made In



BI-METAL

**PART # 275AV04P
PLUMBER'S HOLE SAW KIT**

8 Pc. Set contains:
1 each 3/4" - 7/8" - 1-1/8" - 1-1/2" - 1-3/4" -
2-1/4"
2 Arbors - ARB-2 - ARB-5

**RECOMMENDED
Bi-Metal HOLE SAW
CUTTING SPEEDS IN RPM's**



- ① **LUBRICANTS** - Use a good cutting oil for faster, more efficient cutting in ferrous metals. Cutting oil should not be used when cutting cast iron. Beeswax or paraffin is often used when cutting aluminum.
- ② **CUTTING POSITION** - Do not cut materials at an angle. All the hole saw teeth should be in contact with the material to avoid tooth damage.
- ③ **FEEDS** - For effective cutting, apply level and even pressure. Excessive pressure results in premature wear, dulling of the teeth, and breakage. When cutting material over 1" thick, the saw should be pulled back at intervals to allow chip clearance.

SIZE	MILD STEEL	CAST IRON	TOOL & STAINLESS	BRASS	ALUMINUM
9/16"	580	400	300	790	900
5/8"	550	365	275	730	825
11/16"	500	330	250	665	750
3/4"	460	300	230	600	690
13/16"	425	280	210	560	635
7/8"	390	260	195	520	585
15/16"	370	245	185	495	555
1"	350	235	175	470	525
1-1/16"	325	215	160	435	480
1-1/8"	300	200	150	400	450
1-3/16"	285	190	145	380	425
1-1/4"	275	180	140	360	410
1-5/16"	260	175	135	345	390
1-3/8"	250	165	125	330	375
1-7/16"	240	160	120	315	360
1-1/2"	230	150	115	300	345
1-9/16"	220	145	110	290	330
1-5/8"	210	140	105	280	315
1-11/16"	205	135	100	270	305
1-3/4"	195	130	95	260	295
1-13/16"	190	125	95	250	285
1-7/8"	180	120	90	240	270
2"	170	115	85	230	255
2-1/16"	165	110	80	220	245
2-1/8"	160	105	80	210	240
2-1/4"	150	100	75	200	225
2-5/16"	145	100	75	195	225
2-3/8"	140	95	70	190	220
2-1/2"	135	90	65	180	205
2-9/16"	130	85	65	175	200
2-5/8"	130	85	65	170	195
2-3/4"	125	80	60	160	185
2-7/8"	120	80	60	160	180
3"	115	75	55	150	170
3-1/8"	110	70	55	140	165
3-1/4"	105	70	50	140	155
3-3/8"	100	65	50	130	150
3-1/2"	95	65	45	130	145
3-5/8"	95	60	45	120	140
3-3/4"	90	60	45	120	135
3-7/8"	90	60	45	120	135
4"	85	55	40	110	130
4-1/8"	80	55	40	110	120
4-1/4"	80	55	40	110	120
4-1/2"	75	50	35	100	105
4-3/4"	75	50	35	95	95
5"	65	45	30	90	90
5-1/2"	60	40	25	85	85
5-3/4"	55	35	25	75	75
6"	55	35	25	75	75

Bi-Metal Hole Saws - Variable Pitch

Part #	Dia. Inches	Dia. MM	PIPE TAP SIZE		PIPE ENT. SIZE		Use Arbor
			Inches	MM	Inches	MM	
275HW0011	9/16"	14.3	3/8"				*
275HW0012	5/8"	15.5					*
275HW0013	11/16"	17.5					*
275HW0014	3/4"	19.0	1/2"	13 mm	3/8"	10 mm	*
275HW0114	20mm	20.0					*
275HW0015	13/16"	20.6					*
275HW0016	7/8"	22.2	3/4"	19 mm	1/2"	13 mm	*
275HW0017	15/16"	23.8					*
275HW0018	1"	25.4					*
275HW0185	1-1/16"	27.0					*
275HW0019	1-1/8"	28.8	1"	25 mm	3/4"	19 mm	*
275HW0020	1-3/16"	30.2					*
275HW0021	1-1/4"	31.8					*
275HW0022	1-5/16"	33.3					*
275HW0023	1-3/8"	34.9			1"	25 mm	*
275HW0123	1-7/16"	36.5					**
275HW0024	1-1/2"	38.1	1-1/4"	32 mm			**
275HW0124	1-9/16"	39.7					**
275HW0025	1-5/8"	41.2					**
275HW0125	1-11/16"	42.9					**
275HW0026	1-3/4"	44.5	1-1/2"	38 mm	1-1/4"	32 mm	**
275HW0226	45mm	45.0					**
275HW0126	1-13/16"	46.0					**
275HW0027	1-7/8"	47.6					**
275HW0127	50mm	50.0					**
275HW0028	2"	50.8			1-1/2"	38 mm	**
275HW0128	2-1/16"	52.4					**
275HW0029	2-1/8"	53.9					**
275HW0129	55mm	55.0					**
275HW0030	2-1/4"	57.2	2"	51 mm			**
275HW0031	2-5/16"	58.7					**
275HW0032	2-3/8"	60.3					**
275HW0033	2-1/2"	63.5			2"	51 mm	**
275HW0034	2-9/16"	65.1					**
275HW0134	2-5/8"	66.7	2-1/2"	64 mm			**
275HW0234	68mm	68.0					**
275HW0334	68.5mm	68.5					**
275HW0135	2-3/4"	69.9					**
275HW0136	2-7/8"	73.0					**
275HW0236	75mm	75.0					**
275HW0035	3"	76.2			2-1/2"	64 mm	**
275HW0137	3-1/8"	79.4					**
275HW0138	3-1/4"	82.6	3"	76 mm			**
275HW0139	3-3/8"	85.7					**
275HW0036	3-1/2"	88.9					**
275HW0140	3-5/8"	92.1			3"	76 mm	**
275HW0141	3-3/4"	95.3	3-1/2"	89 mm			**
275HW0142	3-7/8"	98.4					**
275HW0100	100mm	100.0					**
275HW0037	4"	101.6					**
275HW0143	4-1/8"	104.8			3-1/2"	89 mm	**
275HW0144	4-1/4"	108.0	4"	102 mm			**
275HW0038	4-1/2"	114.3			4"	102 mm	**
275HW0145	4-3/4"	120.7	4-1/2"				**
275HW0039	5"	127.0					**
275HW0040	5-1/2"	139.7					**
275HW0146	5-3/4"	146.0					**
275HW0041	6"	152.4					**



1 HOLE SAW PER BOX. ARBOR NOT INCLUDED.

Made In



- ◆ Made In USA
- ◆ Bi-Metal Construction
- ◆ M3 Cutting Edge
- ◆ 5 Variable Pitch. Rc. 63-65
- ◆ Positive Rake
- ◆ 1-15/16" Cutting Depth
- ◆ Premium Quality
- ◆ Cuts Through a 2" x 4"
- ◆ Red Finish



* ARB-0, ARB-1 or ARB-2 with (1/2"-20 Thread).
 ** ARB-3, ARB-4 or ARB-5 with (5/8"-11 Thread).

These High Quality Bi-Metal Hole Saws are made by a very special process. The cutting edge is electron beam welded to a tough alloy steel back. These hole saws are ideal for work where high performance & accuracy are needed. Saws have knock-out holes for easy core removal.



1 HOLE SAW PER BOX.
 ARBOR NOT INCLUDED.

Made In



Wood Fiberboard Plastics



Fiberglass Plaster Acoustic Tile

- ◆ Made In USA
- ◆ Tungsten Carbide Teeth
- ◆ Ground & Welded Set Teeth
- ◆ 3 Teeth Per Inch
- ◆ High Wear Resistance
- ◆ 1-15/16" Cutting Depth
- ◆ Premium Quality
- ◆ Black Finish

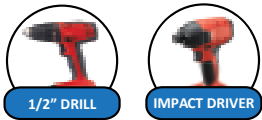

1/2" DRILL

IMPACT DRIVER

- * ARB-0, ARB-1 or ARB-2 with (1/2"-20 Thread).
- ** ARB-3, ARB-4 or ARB-5 with (5/8"-11 Thread).

Carbide Tipped Hole Saws

Part #	Dia.		PIPE TAP SIZE		PIPE ENT. SIZE		Use Arbor
	Inches	MM	Inches	MM	Inches	MM	
AT120034	3/4"	19.0	1/2"	13 mm	3/8"	10 mm	*
AT131316	13/16"	20.6					*
AT140078	7/8"	22.2	3/4"	19 mm	1/2"	13 mm	*
AT151516	15/16"	23.8					*
AT160001	1"	25.4					*
AT171116	1-1/16"	27.0					*
AT180118	1-1/8"	28.8	1"	25 mm	3/4"	19 mm	*
AT191316	1-3/16"	30.2					*
AT200114	1-1/4"	31.8					**
AT211516	1-5/16"	33.3					**
AT220138	1-3/8"	34.9			1"	25 mm	**
AT231716	1-7/16"	36.5					**
AT240112	1-1/2"	38.1	1-1/4"	32 mm			**
AT251916	1-9/16"	39.7					**
AT260158	1-5/8"	41.2					**
AT271116	1-11/16"	42.9					**
AT280134	1-3/4"	44.5	1-1/2"	38 mm	1-1/4"	32 mm	**
AT291316	1-13/16"	46.0					**
AT300178	1-7/8"	47.6					**
AT320002	2"	50.8			1-1/2"	38 mm	**
AT332116	2-1/16"	52.4					**
AT340218	2-1/8"	53.9					**
AT360214	2-1/4"	57.2	2"	51 mm			**
AT372516	2-5/16"	58.7					**
AT380238	2-3/8"	60.3					**
AT400212	2-1/2"	63.5			2"	51 mm	**
AT412916	2-9/16"	65.1					**
AT420258	2-5/8"	66.7	2-1/2"	64 mm			**
AT440234	2-3/4"	69.9					**
AT460278	2-7/8"	73.0					**
AT480003	3"	76.2			2-1/2"	64 mm	**
AT500318	3-1/8"	79.4					**
AT520314	3-1/4"	82.6	3"	76 mm			**
AT540338	3-3/8"	85.7					**
AT560312	3-1/2"	88.9					**
AT580358	3-5/8"	92.1			3"	76 mm	**
AT600334	3-3/4"	95.3	3-1/2"	89 mm			**
AT620378	3-7/8"	98.4					**
AT640004	4"	101.6					**
AT660418	4-1/8"	104.8			3-1/2"	89 mm	**
AT680414	4-1/4"	108.0	4"	102 mm			**
AT700438	4-3/8"	111.0					**
AT720412	4-1/2"	114.3			4"	102 mm	**
AT760434	4-3/4"	120.7					**
AT800005	5"	127.0					**
AT880512	5-1/2"	139.7					**
AT920534	5-3/4"	146.0					**
AT960006	6"	152.4					**

CARBIDE TIPPED & CARBIDE GRIT RPM CHART

SIZE	ALUMINUM	PLASTIC	FIBER-GLASS	CERAMIC TILE	PARTICLE BOARD	CAST IRON	FORMICA
3/4"	1700	3430	250	500	3430	410	210
7/8"	1500	2940	210	430	2940	350	180
1"	1300	2570	190	370	2570	310	150
1-1/8"	1100	2290	170	330	2290	270	140
1-3/8"	900	1870	140	270	1870	220	110
1-1/2"	900	1710	120	250	1710	210	100
1-3/4"	700	1470	110	210	1470	180	90
2"	600	1290	90	190	1290	150	80
2-1/4"	600	1140	80	170	1140	140	70
2-1/2"	500	1030	70	150	1030	120	60
3"	400	860	60	120	860	100	50
3-1/4"	400	790	60	110	790	90	50
3-5/8"	400	710	50	100	710	90	40
3-3/4"	300	690	50	100	690	80	40
4-1/8"	300	620	50	90	620	70	40
4-3/4"	300	540	40	80	540	60	30
5"	200	480	40	80	500	60	30
5-1/2"	200	420	40	70	460	50	30
6"	100	360	30	60	420	40	30



These High Quality Carbide Tipped Hole Saws have the highest wear resistance for abrasive materials. They are ideal for work where high performance & accuracy are needed. Saws have knock-out holes for easy core removal.

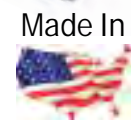

Carbide Grit Hole Saws

Part #	Dia. Inches	Dia. MM	PIPE TAP SIZE		PIPE ENT. SIZE		Use Arbor
			Inches	MM	Inches	MM	
CG0012	3/4"	19.0	1/2"	13 mm	3/8"	10 mm	*
CG0013	13/16"	20.6					*
CG0014	7/8"	22.2	3/4"	19 mm	1/2"	13 mm	*
CG0015	15/16"	23.8					*
CG0016	1"	25.4					*
CG0017	1-1/16"	27.0					*
CG0018	1-1/8"	28.8	1"	25 mm	3/4"	19 mm	*
CG0019	1-3/16"	30.2					*
CG0020	1-1/4"	31.8					**
CG0021	1-5/16"	33.3					**
CG0022	1-3/8"	34.9			1"	25 mm	**
CG0023	1-7/16"	36.5					**
CG0024	1-1/2"	38.1	1-1/4"	32 mm			**
CG0025	1-9/16"	39.7					**
CG0026	1-5/8"	41.2					**
CG0027	1-11/16"	42.9					**
CG0028	1-3/4"	44.5	1-1/2"	38 mm	1-1/4"	32 mm	**
CG0029	1-13/16"	46.0					**
CG0030	1-7/8"	47.6					**
CG0032	2"	50.8			1-1/2"	38 mm	**
CG0033	2-1/16"	52.4					**
CG0034	2-1/8"	53.9					**
CG0036	2-1/4"	57.2	2"	51 mm			**
CG0037	2-5/16"	58.7					**
CG0038	2-3/8"	60.3					**
CG0040	2-1/2"	63.5			2"	51 mm	**
CG0041	2-9/16"	65.1					**
CG0042	2-5/8"	66.7	2-1/2"	64 mm			**
CG0044	2-3/4"	69.9					**
CG0046	2-7/8"	73.0					**
CG0048	3"	76.2			2-1/2"	64 mm	**
CG0050	3-1/8"	79.4					**
CG0052	3-1/4"	82.6	3"	76 mm			**
CG0054	3-3/8"	85.7					**
CG0056	3-1/2"	88.9					**
CG0058	3-5/8"	92.1			3"	76 mm	**
CG0060	3-3/4"	95.3	3-1/2"	89 mm			**
CG0062	3-7/8"	98.4					**
CG0064	4"	101.6					**
CG0066	4-1/8"	104.8			3-1/2"	89 mm	**
CG0068	4-1/4"	108.0	4"	102 mm			**
CG0070	4-3/8"	111.0					**
CG0072	4-1/2"	114.3			4"	102 mm	**
CG0076	4-3/4"	120.7					**
CG0080	5"	127.0					**
CG0088	5-1/2"	139.7					**
CG0092	5-3/4"	146.0					**
CG0096	6"	152.4					**



ARBORS



 Use ARB-0, ARB-1, ARB-2, ARB-3, ARB-4 and ARB-5. With 1/4" HSS Pilot For These Materials.

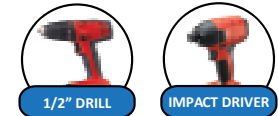

 Use ARB-8 or ARB-9. With 1/4" Carbide Pilot For These Materials.

- ◆ Made In USA
- ◆ Tungsten Carbide Grit
- ◆ Bonded to Alloy Back
- ◆ Gulletted Edge
- ◆ Super Wear Resistance
- ◆ 1-15/16" Cutting Depth
- ◆ Premium Quality
- ◆ Black Finish



* ARB-0, ARB-1, ARB-2 or ARB-8 with (1/2"-20 Thread).
 ** ARB-3, ARB-4, ARB-5 or ARB-9 with (5/8"-11 Thread).



CARBIDE GRIT

RECESSED LIGHTING HOLE SAWS

Part#	Size
CG0104	6-3/8"
CG0110	6-7/8"

These High Quality Carbide Grit Hole Saws are designed for use in hard or abrasive materials such as ceramics, fiberglass, hard woods, cast iron, & composites. They are best suited for thin materials that would strip bi-metal or carbide teeth. Saws have knock-out holes for easy core removal. Use a carbide tipped pilot arbor when drilling ceramics.



1/4" Pilot Drills - HSS



- ◆ Industrial Quality
- ◆ High Speed Steel
- ◆ Designed For Arbors
- ◆ Sold Packs of 10



PART #
277PD0014
 1/4" HSS PILOT DRILL
 3 STEPS



PART #
277PD0016
 1/4" HSS PILOT DRILL
 3 FLATS



PART #
277PD0018
 1/4" HSS PILOT DRILL
 1 FLAT

1/4" Pilot Drills - Carbide



- ◆ Industrial Quality
- ◆ Carbide Head
- ◆ Designed For Arbors
- ◆ Sold Individually



PART #
277PD0020
 1/4" CARBIDE PILOT DRILL
 2-7/8" LONG 1 FLAT



PART #
277PD0022
 1/4" CARBIDE PILOT DRILL
 4" LONG 1 FLAT

Arbor Adapter Nut

PART #
NUT001

Adapter Nut

Turns
 1/2"-20
 Thread
 To 5/8"-18
 Thread



Adapter nut allows smaller arbors without pins to fit larger hole saws. Not recommended for use with hole saws larger than 2-1/2".

Will work with any of the following 1/2"-20 threaded arbors:

- ARB-0
- ARB-1
- ARB-2
- ARB-8

Extension

PART #
EXT001

12" Arbor Extension

For 7/16" Hex Shank Arbors Only!!!

PART #
EXT002

12" Arbor Extension

For 3/8" Hex Shank Arbors Only!!!



3/8" Hex Shank

Arbors - With 1/4" HSS Pilot Drill









- ◆ High Quality
- ◆ Sold Individually in White Boxes
- ◆ Includes one 3-Flats 1/4" HSS Pilot Drill



FOR USE WITH:

- Bi-Metal Hole Saws
- Carbide Tipped Hole Saws
- Carbide Grit Hole Saws

<p>PART #</p> <p>ARB-0</p> <p>1/4" 3-FLAT SHANK ARBOR FOR HOLE SAWS 9/16" - 1-3/16"</p>	 <p>1/2"-20 Thread</p> <p>HSS PILOT 277PD0016</p>
<p>PART #</p> <p>ARB-1</p> <p>1/4" HEX POWER SHANK ARBOR FOR HOLE SAWS 9/16" - 1-3/16"</p>	 <p>1/2"-20 Thread</p> <p>HSS PILOT 277PD0018</p>
<p>PART #</p> <p>ARB-2</p> <p>3/8" HEX POWER SHANK ARBOR FOR HOLE SAWS 9/16" - 1-3/16"</p>	 <p>1/2"-20 Thread</p> <p>HSS PILOT 277PD0018</p>
<p>PART #</p> <p>ARB-3</p> <p>3/8" HEX POWER SHANK FOR HOLE SAWS 1-1/4" - 6"</p>	 <p>5/8"-18 Thread</p> <p>HSS PILOT 277PD0018</p>
<p>PART #</p> <p>ARB-4</p> <p>3/8" HEX POWER SHANK ARBOR FOR HOLE SAWS 1-1/4" - 6"</p>	 <p>5/8"-18 Thread</p> <p>HSS PILOT 277PD0018</p>
<p>PART #</p> <p>ARB-5</p> <p>7/16" HEX POWER SHANK FOR HOLE SAWS 1-1/4" - 6"</p>	 <p>5/8"-18 Thread</p> <p>HSS PILOT 277PD0018</p>

Arbors - With 1/4" Carbide Pilot Drill



- ◆ Use With Carbide Grit Hole Saws
- ◆ Carbide Head
- ◆ Includes one 1/4" Carbide Pilot Drill
- ◆ Sold Individually



<p>PART #</p> <p>ARB-8</p> <p>3/8" HEX POWER SHANK FOR HOLE SAWS 3/4" - 1-3/16"</p>	 <p>1/2"-20 Thread</p> <p>CARBIDE PILOT 277PD0020</p>
<p>PART #</p> <p>ARB-9</p> <p>7/16" HEX POWER SHANK FOR HOLE SAWS 1-1/4" - 6"</p>	 <p>5/8"-18 Thread</p> <p>CARBIDE PILOT 277PD0022</p>



INTERNATIONAL TOOL MANUFACTURING
 150 Express St. Plainview, NY 11803
 (516) 738-0388 • (800) 247-5696
 Fax (516) 279-1106

Made In



- ◆ Made In USA
- ◆ 1/2" Universal Shank
- ◆ Bi-Metal
- ◆ 8% Cobalt
- ◆ Tooth Hardness Rc 65-67



All Purpose Reciprocating Blades - Wood Cutting - Bi-Metal

Part #	Blade Length	Teeth Per Inch	Description	Width / Length	Pack QTY.	Bulk (50 Pcs.) Part #
RB636W	6"	6T	Wood & Nail Slope	3/4" x 6" x .050"	5	BU-RB636W
RB656WS	6"	6T	Wood & Nail Scroll	3/4" x 6" x .050"	5	BU-RB656WS
RB956W	9"	6T	Wood & Nail	3/4" x 9" x .050"	5	BU-RB956W
RB125W	12"	6T	Wood & Nail	3/4" x 12" x .050"	5	BU-RB125W
RB636DW	6"	6T	Drywall - V Tooth	3/4" x 6" x .050"	5	BU-RB636DW

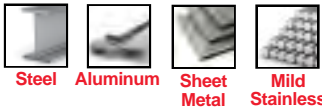

Made In



- ◆ Made In USA
- ◆ 1/2" Universal Shank
- ◆ Bi-Metal
- ◆ 8% Cobalt
- ◆ Tooth Hardness Rc 65-67



All Purpose Reciprocating Blades - Metal Cutting - Bi-Metal

Part #	Blade Length	Teeth Per Inch	Description	Width / Length	Pack QTY.	Bulk (50 Pcs.) Part #
RB414M	4"	14T	Metal	3/4" x 4" x .035"	5	BU-RB414M
RB418M	4"	18T	Metal	3/4" x 4" x .035"	5	BU-RB418M
RB424M	4"	24T	Metal	3/4" x 4" x .035"	5	BU-RB424M
RB610HDM	6"	10T	Metal	3/4" x 6" x .035"	5	BU-RB610HDM
RB614HDM	6"	14T	Metal	3/4" x 6" x .035"	5	BU-RB614HDM
RB618HDM	6"	18T	Metal	3/4" x 6" x .035"	5	BU-RB618HDM
RB624HDM	6"	24T	Metal	3/4" x 6" x .035"	5	BU-RB624HDM
RB810HDM	8"	10T	Metal 10/14 V.P.	3/4" x 8" x .035"	5	BU-RB810HDM
RB814HDM	8"	14T	Metal	3/4" x 8" x .035"	5	BU-RB814HDM
RB818HDM	8"	18T	Metal	3/4" x 8" x .035"	5	BU-RB818HDM
RB1010HDM	10"	10T	Metal	3/4" x 10" x .035"	5	BU-RB1010HDM
RB1018HDM	10"	18T	Metal	3/4" x 10" x .035"	5	BU-RB1018HDM
RB1218HDM	12"	18T	Metal	3/4" x 12" x .035"	5	BU-RB1218HDM
R8CCRF	8"	CARBIDE GRIT	Cast Iron Ceramics	3/4" x 8" x .050"	1	BU-R8CCRF



Made In



Steel



Aluminum



Sheet Metal



Mild Stainless

- ◆ Made In USA
- ◆ 1/2" Universal Shank
- ◆ Bi-Metal
- ◆ 8% Cobalt
- ◆ Tooth Hardness Rc 65-67



HEAVY METAL Reciprocating Blades - Bi-Metal

Part #	Blade Length	Teeth Per Inch	Description	Width / Length	Pack QTY.	Bulk (50 Pcs.) Part #
HM610	6"	10T	Heavy Metal	1" x 6" x .042"	5	BU-HM610
HM614	6"	14T	Heavy Metal	1" x 6" x .042"	5	BU-HM614
HM618	6"	18T	Heavy Metal	1" x 6" x .042"	5	BU-HM618
HM910	9"	10T	Heavy Metal	1" x 9" x .042"	5	BU-HM910
HM914	9"	14T	Heavy Metal	1" x 9" x .042"	5	BU-HM914
HM918	9"	18T	Heavy Metal	1" x 9" x .042"	5	BU-HM918
HM1214	12"	14T	Heavy Metal	1" x 12" x .042"	5	BU-HM1214
HM1218	12"	18T	Heavy Metal	1" x 12" x .042"	5	BU-HM1218



Made In



Cast Iron



Steel



Stainless



Sheet Metal

- ◆ Made In USA
- ◆ 1/2" Universal Shank
- ◆ Carbide Teeth
- ◆ Rigid Blade Body
- ◆ 8 Teeth Per Inch
- ◆ Metal Cutting



MAX METAL Carbide Tipped Reciprocating Blades

Part #	Blade Length	Teeth Per Inch	Description	Width / Length	Pack QTY.	Bulk (25 Pcs.) Part #
CT6	6"	8T	Carbide Teeth	1" x 6" x .050"	1	CT6-B
CT9	9"	8T	Carbide Teeth	1" x 9" x .050"	1	CT9-B



Wood - Metal - Heavy Metal
Sleeve of 5 or box of 50.
Carbide Tipped
Sleeve of 1 or tube of 25.

CUT FASTER.
CUT LONGER.





INTERNATIONAL TOOL MANUFACTURING
 150 Express St. Plainview, NY 11803
 (516) 738-0388 • (800) 247-5696
 Fax (516) 279-1106

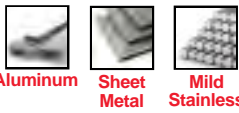

VIGOR™ Heavy Duty Reciprocating Blades - Bi-Metal

Part #	Blade Length	Teeth Per Inch	Description	Width / Length	Pack QTY.	Bulk (50 Pcs.) Part #
VIHD61014	6"	10/14 V.P.	Heavy Duty	3/4" x 6" x .050"	5	BU-VIHD61014
VIHD81014	8"	10/14 V.P.	Heavy Duty	3/4" x 8" x .050"	5	BU-VIHD81014
VIHD12014	12"	10/14 V.P.	Heavy Duty	3/4" x 12" x .050"	5	BU-VIHD12014

V.P. = Variable Pitch (Teeth)

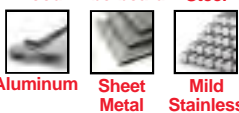

VIGOR™ Demolition Reciprocating Blades - Bi-Metal

Part #	Blade Length	Teeth Per Inch	Description	Width / Length	Pack QTY.	Bulk (25 Pcs.) Part #
VIDM60006	6"	6T	Demolition	7/8" x 6" x .062"	3	BU-VIDM60006
VIDM60010	6"	10T	Demolition	7/8" x 6" x .062"	3	BU-VIDM60010
VIDM90006	9"	6T	Demolition	7/8" x 9" x .062"	3	BU-VIDM90006
VIDM90010	9"	10T	Demolition	7/8" x 9" x .062"	3	BU-VIDM90010
VIDM12006	12"	6T	Demolition	7/8" x 12" x .062"	3	BU-VIDM12006
VIDM12010	12"	10T	Demolition	7/8" x 12" x .062"	3	BU-VIDM12010

Heavy Duty
 Sleeve of 5 or box of 50.
Demolition
 Sleeve of 3 or box of 25.

- Made In** **Made In USA**
- ◆ 1/2" Universal Shank
 - ◆ Bi-Metal
 - ◆ 8% Cobalt
 - ◆ Tooth Hardness Rc 65-67
 - ◆ 45% Thicker Than All Purpose Blades
 - ◆ Wider Than All Purpose Blades
 - ◆ Stay Rigid
 - ◆ No Vibration
-
- RECIPROCATING SAW

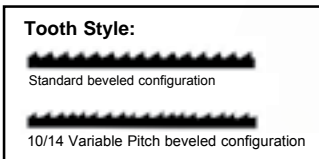



High Tension Hack Saw Frame

Part #	Description
278HX0002	High Tension Hack Saw Frame

This High Tension Hack Saw Frame features a **NEW Cushin' Grip** handle and end pieces made of die cast aluminum. It is light weight yet extremely rigid and high tensioned; which provides cleaner, surer cuts. The blade can be set at a 55° angle for special flush cutting jobs (see figure A). The blade can also be inserted into the front end of the hack saw frame, and used as a versatile compass saw (see figure B). This frame fits most standard tool boxes.



- ◆ RED Cast Aluminum
- ◆ Light Weight
- ◆ Extremely Rigid
- ◆ Versatile
- ◆ 25,000 lbs Per Square Inch
- ◆ Includes 1 12" x 24T Bi-Metal Blade
- ◆ Sold Individually

Hack Saw Blades - Bi-Metal

Part #	OAL	Teeth Per Inch	Wide	Thick	QTY.
278BM0018	12"	18T	1/2"	.025"	10
278BM0024	12"	24T	1/2"	.025"	10
278BM0032	12"	32T	1/2"	.025"	10



- ◆ Bi-Metal
- ◆ 8% Cobalt
- ◆ Premium Quality
- ◆ White Finish

Band Saw Blades - Bi-Metal

Part #	OAL	Teeth Per Inch	Wide	Thick	QTY.
B320018 *	32-7/8"	18T	1/2"	.020"	3
B321418 *	32-7/8"	14/18T	1/2"	.020"	3
B350018 **	35-3/8"	18T	1/2"	.020"	3
B351418 **	35-3/8"	14/18T	1/2"	.020"	3
279SB0014	44-7/8"	14T	1/2"	.020"	3
279SB0018	44-7/8"	18T	1/2"	.020"	3
279SB0024	44-7/8"	24T	1/2"	.020"	3
279VP1014	44-7/8"	10/14	1/2"	.020"	3
279VP1418	44-7/8"	14/18	1/2"	.020"	3



- ◆ Made In USA
- ◆ Bi-Metal
- ◆ 8% Cobalt
- ◆ Premium Quality
- ◆ Standard or Variable Pitch
- ◆ Use In All Hand Held Band Saws

* DEWALT® - DCS370L, B, K
 ** MILWAUKEE® - M18 (2629-20), 6242-6, 2629-22

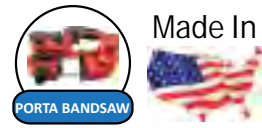

Drywall Cutter - M2 HSS

Part #	Size	OAL	Qty.
DW-316	3/16"	3-1/4"	1



- ◆ 1/4" Shank
- ◆ Electrical Boxes
- ◆ Air Ducts





Retail Packs



All Purpose Reciprocating Blades - Bi-Metal

Part #	Blade Length	Teeth Per Inch	Pack Description	Width / Length	QTY.
W636	6"	6T	Wood & Nail Slope	3/4" x 6" x .050"	5
W956	9"	6T	Wood & Nail	3/4" x 9" x .050"	5
W125	12"	6T	Wood & Nail	3/4" x 12" x .050"	5
M614	6"	14T	Metal	3/4" x 6" x .035"	5
M618	6"	18T	Metal	3/4" x 6" x .035"	5
M624	6"	24T	Metal	3/4" x 6" x .035"	5
M810	8"	10T	Metal	3/4" x 8" x .035"	5
M814	8"	14T	Metal	3/4" x 8" x .035"	5
M818	8"	18T	Metal	3/4" x 8" x .035"	5
M1218	12"	18T	Metal	3/4" x 12" x .035"	5

Made In



- ◆ Made In USA
- ◆ Same Bi-Metal Blades On P. 62 & 64
- ◆ Slim Line Retail Packs
- ◆ Price Per Pack



VIGOR™ Heavy Duty and Demolition - Bi-Metal

Part #	Blade Length	Teeth Per Inch	Pack Description	Width / Length	QTY.
HD610	6"	10/14T	Heavy Duty	3/4" x 6" x .050"	5
HD810	8"	10/14T	Heavy Duty	3/4" x 8" x .050"	5
HD120	12"	10/14T	Heavy Duty	3/4" x 12" x .050"	5
DM606	6"	6T	Demolition	7/8" x 6" x .062"	3
DM610	6"	10T	Demolition	7/8" x 6" x .062"	3
DM906	9"	6T	Demolition	7/8" x 9" x .062"	3
DM910	9"	10T	Demolition	7/8" x 9" x .062"	3
DM1206	12"	6T	Demolition	7/8" x 12" x .062"	3
DM1210	12"	10T	Demolition	7/8" x 12" x .062"	3



Rack P. 72



Bulk Retail Packs

All Purpose Reciprocating Blades - Bi-Metal

Part #	Blade Length	Teeth Per Inch	Pack Description	Width / Length	QTY.
W636-B	6"	6T	Wood & Nail Slope	3/4" x 6" x .050"	50
W956-B	9"	6T	Wood & Nail	3/4" x 9" x .050"	50
W125-B	12"	6T	Wood & Nail	3/4" x 12" x .050"	50
M614-B	6"	14T	Metal	3/4" x 6" x .035"	50
M618-B	6"	18T	Metal	3/4" x 6" x .035"	50
M624-B	6"	24T	Metal	3/4" x 6" x .035"	50
M810-B	8"	10T	Metal	3/4" x 8" x .035"	50
M814-B	8"	14T	Metal	3/4" x 8" x .035"	50
M818-B	8"	18T	Metal	3/4" x 8" x .035"	50
M1218-B	12"	18T	Metal	3/4" x 12" x .035"	50



VIGOR™ Heavy Duty and Demolition - Bi-Metal

Part #	Blade Length	Teeth Per Inch	Pack Description	Width / Length	QTY.
HD610-B	6"	10/14T	Heavy Duty	3/4" x 6" x .050"	50
HD810-B	8"	10/14T	Heavy Duty	3/4" x 8" x .050"	50
HD120-B	12"	10/14T	Heavy Duty	3/4" x 12" x .050"	50
DM606-B	6"	6T	Demolition	7/8" x 6" x .062"	25
DM610-B	6"	10T	Demolition	7/8" x 6" x .062"	25
DM906-B	9"	6T	Demolition	7/8" x 9" x .062"	25
DM910-B	9"	10T	Demolition	7/8" x 9" x .062"	25
DM1206-B	12"	6T	Demolition	7/8" x 12" x .062"	25
DM1210-B	12"	10T	Demolition	7/8" x 12" x .062"	25

Made In



- ◆ Made In USA
- ◆ Same Bi-Metal Blades On P. 62 & 64
- ◆ Slim Line Retail Packs
- ◆ Price Per Pack

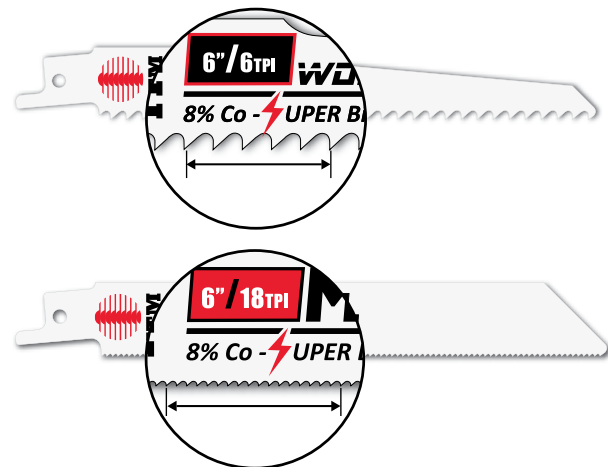



- ◆ Bi-Metal
- ◆ 8% Cobalt
- ◆ Deep Plunge Depth
- ◆ Premium Quality



Retail (1)



Bulk (10)

- Wood**
- Metal**
- Drywall**



Oscillating Blades - Wood / Plastic

	Part #	Teeth	Width	Plunge	Qty.
	OW-2	BIM-Japanese	1-3/8"	1-1/2"	1
	OW-2B	BIM-Japanese	1-3/8"	1-1/2"	10
	OW-3	BIM-Japanese	1-3/4"	2-1/4"	1
	OW-3B	BIM-Japanese	1-3/4"	2-1/4"	10
	MLW-2	BIM-Japanese	1-3/8"	1-1/2"	1
	MLW-2B	BIM-Japanese	1-3/8"	1-1/2"	10
	MLW-3	BIM-Japanese	1-3/4"	2-1/4"	1
	MLW-3B	BIM-Japanese	1-3/4"	2-1/4"	10

Oscillating Blades - Metal / Wood & Nail

	Part #	Teeth	Width	Plunge	Qty.
	OM-2	BIM-Titanium	1-3/8"	1-1/2"	1
	OM-2B	BIM-Titanium	1-3/8"	1-1/2"	10
	OM-3	BIM-Titanium	1-3/4"	2-1/4"	1
	OM-3B	BIM-Titanium	1-3/4"	2-1/4"	10
	MLM-2	BIM-Titanium	1-3/8"	1-1/2"	1
	MLM-2B	BIM-Titanium	1-3/8"	1-1/2"	10
	MLM-3	BIM-Titanium	1-3/4"	2-1/4"	1
	MLM-3B	BIM-Titanium	1-3/4"	2-1/4"	10

Oscillating Blades - Drywall / Wood

	Part #	Teeth	Width	Plunge	Qty.
	WDR-3	BIM-Drywall	3-1/2"	3/4"	1

OSCILLATING BLADES



- ◆ Bi-Metal
- ◆ Deep Plunge Depth
- ◆ Premium Quality



Wood

Metal

Drywall



OPEN



MULTI



OPEN



OPEN



MULTI



BI-METAL JAPANESE TEETH



BI-METAL JAPANESE TEETH



BI-METAL DRYWALL



BI-METAL TITANIUM COATED



BI-METAL TITANIUM COATED

Part #	Size	Qty.
--------	------	------



OSCILLATING BLADES

Oscillating Blades

Part #	Contents
RACK20	Black Header - 10 Prong
H-9	Oscillating Blade Header
DIS-OSC	Oscillating Blades

OM-2	1-3/8" X 1-1/2" (OPEN METAL)	10
OM-3	1-3/4" X 2-1/4" (OPEN METAL)	10
OW-2	1-3/8" X 1-1/2" (OPEN WOOD)	10
OW-3	1-3/4" X 2-1/4" (OPEN WOOD)	10
MLM-2	1-3/8" X 1-1/2" (MULTI METAL)	10
MLM-3	1-3/4" X 2-1/4" (MULTI METAL)	10
MLW-2	1-3/8" X 1-1/2" (MULTI WOOD)	10
MLW-3	1-3/4" X 2-1/4" (MULTI WOOD)	10
WDR-3	3-1/2" CIRCLE (OPEN DRYWALL)	10

RACK20
7"Out X 17"H X 20"W







RETAIL READY DISPLAYS

Fits All Standard Pegboards & Slatwall Panels

Part #	Size	Qty.
VG-4001B	1/8" X 3" - 25 PC.	2
VG-4002B	3/16" X 4" - 25 PC.	2
VG-4003B	1/4" X 4" - 25 PC.	2
VG-6001B	3/16" X 6" - 25 PC.	2
VG-6002B	1/4" X 6" - 25 PC.	2
VG-4002	3/16" X 4"	25
VG-4003	1/4" X 4"	25
VG-6001	3/16" X 6"	25
VG-6002	1/4" X 6"	25
VG-6003	5/16" X 6"	10
VG-6004	3/8" X 6"	5
VG-6005	1/2" X 6"	5



V GROOVE Tile Bit

Part #	Contents
RACK12	Black Header - 12 Prong
H-2	V GROOVE Header
DIS-VG	V GROOVE Tile Bits



#1 IN TILE DRILLING P. 80

HEX-12	3/16" X 2-5/8"	10
HEX-14	1/4" X 2-5/8"	10
HEX-16	5/16" X 3-1/8"	6
HEX-18	3/8" X 3-1/8"	6
HEX-20	1/2" X 3-1/8"	6
HEX-22	5/8" X 2-3/4"	5
HEX-24	3/4" X 2-3/4"	5
HEX-26	7/8" X 2-3/4"	5
HEX-28	1" X 2-3/4"	5

White Diamond Tile - Hex



Part #	Contents
RACK30	Black Header - 9 Prong
H-8	White Diamond Header
DIS-WD9	White Diamond - HEX



WHITE DIAMOND P. 82

RACK30
 7"Out X 8"H X 23"W

HEX-12	3/16" X 2-5/8"	10
HEX-14	1/4" X 2-5/8"	10
HEX-16	5/16" X 3-1/8"	6
HEX-18	3/8" X 3-1/8"	6
HEX-20	1/2" X 3-1/8"	6
HEX-22	5/8" X 2-3/4"	5
HEX-24	3/4" X 2-3/4"	5
HEX-26	7/8" X 2-3/4"	5
HEX-28	1" X 2-3/4"	5
ANG-26	7/8" X 2-3/8"	5
ANG-28	1" X 2-3/8"	5
ANG-30	1-1/8" X 2-3/8"	3
ANG-32	1-1/4" X 2-3/8"	3
ANG-34	1-3/8" X 2-3/8"	3
ANG-36	1-1/2" X 2-3/8"	3
ANG-38	2" X 2-3/8"	3
ANG-40	2-1/2" X 2-3/8"	3
PAD-5811	ADAPTER 5/8"-11	6

White Diamond Tile - Full

Part #	Contents
RACK35	Black Header - 19 Prong
H-8	White Diamond Header
DIS-WD19	White Diamond - HEX & Angle



WHITE DIAMOND P. 82

RACK35
 7"Out X 23"H X 23"W

Part #	Size	Qty.
RL-41264	3/16" X 4-1/4"	10
RL-61264	3/16" X 6-1/4"	10
RL-41664	1/4" X 4-1/4"	10
RL-61664	1/4" X 6-1/4"	10
RL-62464	3/8" X 6-1/4"	10
RL-12038	3/8" X 12-1/4"	10
RL-63264	1/2" X 6-1/4"	10
RL-12012	1/2" X 12-1/4"	10
RL-84064	5/8" X 8-1/4"	10
RL-84864	3/4" X 8"	5
RL-85664	7/8" X 8"	5
RL-10001	1" X 10"	5

SDS-Plus - Redline

Part #	Contents
RACK12	Black Header - 12 Prong
H-4	SDS Redline Header
DIS-REDL	SDS Redline Bits - Starter

REDLINE STARTER - P. 90



715S41264	3/16" X 4-1/2"	10
715S61264	3/16" X 6-1/2"	10
715S41664	1/4" X 4-1/2"	10
715S61664	1/4" X 6-1/2"	10
715S62464	3/8" X 6-1/2"	10
715S82464	3/8" X 8-1/2"	10
715S63264	1/2" X 6-1/2"	10
715S12012	1/2" X 12-1/2"	10
715S84064	5/8" X 8-1/4"	5
715S84864	3/4" X 8"	5
715S85664	7/8" X 8"	5
715S10001	1" X 10"	5

SDS-Plus - Bohr Hammer

Part #	Contents
RACK12	Black Header - 12 Prong
H-5	SDS Bohr Hammer Header
DIS-BOHR	SDS Bohr Hammer Bits - Starter

BOHR HAMMER STARTER - P. 92-93



715S61064	5/32" X 6-1/4"	10
715S61264	3/16" X 6-1/2"	10
715S81264	3/16" X 8-1/2"	10
715S41664	1/4" X 4-1/2"	10
715S61664	1/4" X 6-1/2"	10
715S81664	1/4" X 8-1/2"	10
715S62064	5/16" X 6-1/2"	10
715S62464	3/8" X 6-1/2"	10
715S63264	1/2" X 6-1/2"	5
715S10012	1/2" X 10-1/2"	5
715S84064	5/8" X 8"	5
715S84864	3/4" X 8"	5

SDS-Plus - Bohr Hammer

Part #	Contents
RACK12	Black Header - 12 Prong
H-5	SDS Bohr Hammer Header
DIS-B12S	SDS Bohr Hammer Bits - Short

BOHR HAMMER SHORT - P. 92-93



715S10316	3/16" X 10-1/2"	6
715S12316	3/16" X 12-1/2"	6
715S10014	1/4" X 10-1/2"	6
715S14014	1/4" X 14"	6
715S82464	3/8" X 8-1/2"	6
715S12038	3/8" X 12-1/2"	6
715S18038	3/8" X 18"	6
715S12012	1/2" X 12-1/2"	6
715S12058	5/8" X 12-1/4"	3
715S12034	3/4" X 12"	3
715S12078	7/8" X 12"	3
715S18001	1" X 18"	3

SDS-Plus - Bohr Hammer

Part #	Contents
RACK12	Black Header - 12 Prong
H-5	SDS Bohr Hammer Header
DIS-B12L	SDS Bohr Hammer Bits - Long

BOHR HAMMER LONG - P. 92-93



EVL61064	5/32" X 6-1/2"	10
EVL41264	3/16" X 4-1/2"	10
EVL61264	3/16" X 6-1/2"	10
EVL81264	3/16" X 8-1/2"	10
EVL41664	1/4" X 4-1/2"	10
EVL61664	1/4" X 6-1/2"	10
EVL81664	1/4" X 8-1/2"	10
EVL62064	5/16" X 6-1/2"	10
EVL62464	3/8" X 6-1/4"	10
EVL12038	3/8" X 12-1/4"	10
EVL63264	1/2" X 6-1/4"	10
EVL12012	1/2" X 12-1/4"	5

SDS-Plus - Evolution



Part #	Contents
RACK12	Black Header - 12 Prong
H-6	SDS Evolution Header
DIS-EVO	SDS Evolution Bits - Starter

eVolution STARTER - P. 96





Part #	Size	Qty.
255H04	1/16" X 1-7/8"	12
255H06	3/32" X 2-1/4"	12
255H08	1/8" X 2-3/4"	12
255H10	5/32" X 3-1/8"	12
255H12	3/16" X 3-1/2"	12
255H14	7/32" X 3-3/4"	12
255H16	1/4" X 4"	12
255H18	9/32" X 4-1/4"	12
255H20	5/16" X 4-1/2"	12
255H24	3/8" X 5"	12
255H28	7/16" X 5-1/2"	6
255H32	1/2" X 6"	6





1/4" Hex Titanium Jobbers

Part #	Contents
RACK12	Black Header - 12 Prong
H-3	HEX Titanium Header
DIS-THEX	HEX Titanium Jobber Drills

TITANIUM NITRIDE P. 24

HF0016	7/8" (3/16" Depth)	2
HF0019	1-1/8" (3/16" Depth)	2
HF0023	1-3/8" (3/16" Depth)	2
HG0016	7/8" (1/2" Depth)	2
HG0019	1-1/8" (1/2" Depth)	2
HG0023	1-3/8" (1/2" Depth)	2
HM0016	7/8" (1-3/8" Depth)	2
HM0019	1-1/8" (1-3/8" Depth)	2
HM0023	1-3/8" (1-3/8" Depth)	2





T.C.T. Hole Cutter

Part #	Contents
RACK12	Black Header - 12 Prong
H-7	TCT Hole Cutter Header
DIS-TCT	TCT Hole Cutters

TUNGSTEN CARBIDE P. 54-55

W636	6" X 6T	3
W956	9" X 6T	3
W125	12" X 6T	3
M1218	12" X 18T	3
M810	8" X 10T	3
M814	8" X 14T	3
M818	8" X 18T	3
M614	6" X 14T	3
M618	6" X 18T	3
M624	6" X 24T	3







Reciprocating Blades

Part #	Contents
RACK10	Red Header - 10 Prong
H-10	Reciprocating Blade Header
DIS-RECP	Reciprocating Blades

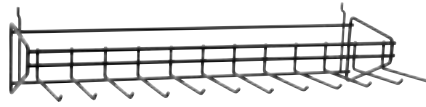
RACK10
3"Out X 8"H X 12"W

BI-METAL 8% COBALT P. 66

 <p>RACK12 7"Out X 8"H X 24"W 1/4" Metal Wire</p>	 <p>RACK18 15"Out X 8"H X 24"W 1/4" Metal Wire</p>																
 <p>P. 100 P. 112 P. 90 P. 92 P. 96 P. 54</p>	<p>ITM Displays - Empty</p> <table border="1"> <thead> <tr> <th>Part #</th> <th>Rack</th> </tr> </thead> <tbody> <tr><td>RACK10</td><td>Reciprocating Blade</td></tr> <tr><td>RACK12</td><td>Top Header</td></tr> <tr><td>RACK18</td><td>Bottom Extra</td></tr> <tr><td>RACK20</td><td>Oscillating Blade</td></tr> <tr><td>RACK30</td><td>White Diamond - Hex Only</td></tr> <tr><td>RACK35</td><td>White Diamond - Hex & Grinder</td></tr> <tr><td>H-1</td><td>Anything That Makes a Hole Header</td></tr> </tbody> </table>	Part #	Rack	RACK10	Reciprocating Blade	RACK12	Top Header	RACK18	Bottom Extra	RACK20	Oscillating Blade	RACK30	White Diamond - Hex Only	RACK35	White Diamond - Hex & Grinder	H-1	Anything That Makes a Hole Header
Part #	Rack																
RACK10	Reciprocating Blade																
RACK12	Top Header																
RACK18	Bottom Extra																
RACK20	Oscillating Blade																
RACK30	White Diamond - Hex Only																
RACK35	White Diamond - Hex & Grinder																
H-1	Anything That Makes a Hole Header																

Made In 

- ◆ Heavy Duty
- ◆ Black Oxide Finish

All individually packed **ITM** drill bits have barcode and can be hung on this display. Simple and hassle free.



Electrician's Flex Bit With Screw Point - Stretch Bit

Part #	Size	X	OAL	Shank	Application
308FB2438	3/8"	X	24"	3/16"	Popular with alarm & communication installers for pulling light wire.
308FB3638	3/8"	X	36"	3/16"	
308FB5438	3/8"	X	54"	3/16"	
308FB7238	3/8"	X	72"	3/16"	
308FB2412	1/2"	X	24"	3/16"	Popular with alarm & communication installers for pulling light wire.
308FB3612	1/2"	X	36"	3/16"	
308FB5412	1/2"	X	54"	3/16"	
308FB7212	1/2"	X	72"	3/16"	

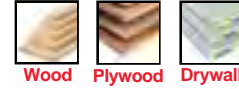

Wood Plywood Drywall

- ◆ Screw Point
- ◆ Self Drilling
- ◆ Fish Hole On Each End
- ◆ Flexible Shaft
- ◆ Sold Individually



FISH HOLE ON SHANK



Stretch Bits are constructed of a high carbon steel self-feed auger bit, permanently brazed to a flexible shaft. This tool can be inserted through small wall openings enabling the operator to bore holes through studs within the wall cavities without damaging finished walls or ceilings.

Eye Holes are provided at each end of the Stretch Bits which allow easy retrieval of wires from either direction after drilling.

Steering Guide

Part #	Description	Application
308FBG	Steering Guide	Helps manipulate bits while within the wall cavity.



Circular Saw Blades

Part #	Size	Box Qty.
DS-58-724	7-1/4" X 24T	25
CS-58-824	8-1/4" X 24T	25
CS-58-840	8-1/4" X 40T	25



Wood Plywood

- ◆ Tungsten Carbide Tipped
- ◆ 5/8" Arbor With Diamond Knock Out
- ◆ 7000 RPM Maximum
- ◆ Hard Body 38-42 Rc.
- ◆ K20 Tungsten Carbide Grade
- ◆ Individually Protected
- ◆ Individually Barcoded
- ◆ Imported

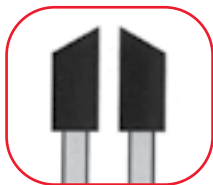

ALTERNATE TOP BEVELED TEETH





HSS Bell Hanger - Feeler Bits With Fish Hole (Electrical / Wire)



- ◆ Fish Hole In Flute For Pulling Wire
- ◆ Special Point For Fast Drilling In Wood & Metal
- ◆ Tapering For Quick Chip Clearance

- Telephone Installation
- Burglar Alarms
- Wire & Cable Applications



Part #	Size	OAL	Shank	Qty.	Part #	Size	OAL	Shank	Qty.
308BH1200	3/16"	12"	3/16"	1	308BH2403	3/8"	24"	3/8"	1
308BH1800	3/16"	18"	3/16"	1	308BH3003	3/8"	30"	3/8"	1
308BH1201	1/4"	12"	1/4"	1	308BH4203	3/8"	42"	3/8"	1
308BH1801	1/4"	18"	1/4"	1	308BH4803	3/8"	48"	3/8"	1
308BH2401	1/4"	24"	1/4"	1	308BH1806	7/16"	18"	3/8"	1
308BH3001	1/4"	30"	1/4"	1	308BH1204	1/2"	12"	1/2"	1
308BH4201	1/4"	42"	1/4"	1	308BH1804	1/2"	18"	1/2"	1
308BH1202	5/16"	12"	5/16"	1	308BH2404	1/2"	24"	1/2"	1
308BH1802	5/16"	18"	5/16"	1	308BH3004	1/2"	30"	1/2"	1
308BH2402	5/16"	24"	5/16"	1	308BH4204	1/2"	42"	1/2"	1
308BH1203	3/8"	12"	3/8"	1	308BH4804	1/2"	48"	1/2"	1
308BH1803	3/8"	18"	3/8"	1	308BH1858	5/8"	18"	1/2"	1
					308BH1805	3/4"	18"	1/2"	1
					308BH1810	1"	18"	1/2"	1



CARBON STEEL Bell Hanger - Feeler Bits With Fish Hole



ALL BELL HANGER DRILL BITS ARE SOLD INDIVIDUALLY

Part #	Size	OAL	Shank	Qty.	Part #	Size	OAL	Shank	Qty.
308CS1412	1/4"	12"	1/4"	1	308CS3818	3/8"	18"	3/8"	1
308CS1418	1/4"	18"	1/4"	1	308CS3824	3/8"	24"	3/8"	1
308CS1424	1/4"	24"	1/4"	1	308CS1804	1/2"	18"	3/8"	1

Less expensive than High Speed Steel (HSS) - Carbon Steel drills all wood, studs, aluminum, insulation, and drywall. Will not perform as well as HSS in steel.



Carbide Tip Bell Hanger - Feeler Bits With Fish Hole (Electrical / Wire)



- ◆ Fish Hole In Flute For Pulling Wire
- ◆ Special Point For Fast Drilling In Masonry & Wood

- Telephone Installation
- Burglar Alarms
- Wire & Cable Applications



Part #	Size	OAL	Shank	Qty.	Part #	Size	OAL	Shank	Qty.
308CT1301	1/4"	13"	1/4"	1	308CT1304	1/2"	13"	3/8"	1
308CT1801	1/4"	18"	1/4"	1	308CT1804	1/2"	18"	3/8"	1
308CT2401	1/4"	24"	1/4"	1	308CT2404	1/2"	24"	3/8"	1
308CT1302	5/16"	13"	5/16"	1	308CT3004	1/2"	30"	3/8"	1
308CT1802	5/16"	18"	5/16"	1	308CT1305	3/4"	13"	1/2"	1
308CT2402	5/16"	24"	5/16"	1	308CT1805	3/4"	18"	1/2"	1
308CT1303	3/8"	13"	3/8"	1					
308CT1803	3/8"	18"	3/8"	1					
308CT2403	3/8"	24"	3/8"	1					
308CT3003	3/8"	30"	3/8"	1					
308CT3638	3/8"	36"	3/8"	1					

12" Long Boy - HSS

Part #	Size	Dec.	OAL	Flute	Qty.
216HS0864	1/8"	.1250	12"	9"	1
216HS1264	3/16"	.1875	12"	9"	1
216HS1464	7/32"	.2188	12"	9"	1
216HS1664	1/4"	.2500	12"	9"	1
216HS1864	9/32"	.2812	12"	9"	1
216HS2064	5/16"	.3125	12"	9"	1
216HS2464	3/8"	.3750	12"	9"	1
216HS2864	7/16"	.4375	12"	9"	1
216HS3264	1/2"	.5000	12"	9"	1
216HS3664	9/16"	.5625	12"	9"	1
216HS4064	5/8"	.6250	12"	9"	1
216HS4464	11/16"	.6875	12"	9"	1
216HS4864	3/4"	.7500	12"	9"	1
216HS5264	13/16"	.8125	12"	9"	1
216HS5664	7/8"	.8750	12"	9"	1
216HS6064	15/16"	.9375	12"	9"	1
216HS6464	1"	1.000	12"	9"	1
216HS7264	1-1/8"	1.1250	12"	9"	1



118° POINT



Mild Steel Aluminum Wood

- ◆ M2 HSS
- ◆ Straight Shank To 1/2", Then Reduced
- ◆ Sharp Cutting Edge To Drill In Many Different Materials



- ⊙ Precision point angle for effective penetration through steel and wood.
- ⊙ Extra length flute with continuous cutting edges for drilling deep holes and fast chip removal.
- ⊙ Reduced shank fits all drill motors with 1/2" chucks.
- ⊙ Non-slip grips prevent the bit from spinning in the chuck.

18" Long Boy - HSS

Part #	Size	Dec.	OAL	Flute	Qty.
217HS1664	1/4"	.2500	18"	14"	1
217HS2064	5/16"	.3125	18"	14"	1
217HS2464	3/8"	.3750	18"	14"	1
217HS3064	15/32"	.4688	18"	14"	1
217HS3264	1/2"	.5000	18"	14"	1
217HS4064	5/8"	.6250	18"	14"	1
217HS4864	3/4"	.7500	18"	14"	1



Brad Point Wood Drill

Part #	Size	OAL	Shank	Qty.
309BP0864	1/8"	2-1/2"	1/8"	1
309BP1064	5/32"	3-1/8"	5/32"	1
309BP1264	3/16"	3-3/8"	3/16"	1
309BP1664	1/4"	4"	1/4"	1
309BP2064	5/16"	4-5/8"	5/16"	1
309BP2464	3/8"	4-7/8"	3/8"	1
309BP2864	7/16"	5-1/2"	3/8"	1
309BP3264	1/2"	6"	3/8"	1
309BP4064	5/8"	7"	3/8"	1
309BP4864	3/4"	7-3/4"	3/8"	1
309BP5664	7/8"	8-1/8"	3/8"	1
309BP6464	1"	8-1/2"	3/8"	1



Great For Acrylics!



Wood Fiberboard Plastics

- ◆ Precision Ground Flute
- ◆ Center Spur
- ◆ Two Shoulder Cutting Spurs
- ◆ Industrial Quality

Part # 309BP0007
7 Pc. Set Woodworking
 1/8" - 3/16" - 1/4" - 5/16" - 3/8" -
 7/16" - 1/2"





SOLD INDIVIDUALLY
 1 PER POUCH.



WING TIP



- ◆ 1/4" Hex Impact Shank
- ◆ Cold Forged
- ◆ Full Length Treated
- ◆ Machine Finish Cutting Groove
- ◆ Rust Protection
- ◆ Wing Tip Design
- ◆ Individually Stamped With Size
- ◆ Industrial Quality



Part # 300-ST-06
6 Pc. Spade Bit Set
 3/8" - 1/2" - 5/8"
 3/4" - 7/8" - 1"



IMPACT
 1/4" HEX IMPACT SHANK

6" Long Spade Wood Drill

Part #	Size	OAL	Qty.
300SB1664	1/4"	6"	1
300SB2064	5/16"	6"	1
300SB2464	3/8"	6"	1
300SB2864	7/16"	6"	1
300SB3264	1/2"	6"	1
300SB3664	9/16"	6"	1
300SB4064	5/8"	6"	1
300SB4464	11/16"	6"	1
300SB4864	3/4"	6"	1
300SB5264	13/16"	6"	1
300SB5664	7/8"	6"	1
300SB6064	15/16"	6"	1
300SB6464	1"	6"	1
300SB7264	1-1/8"	6"	1
300SB8064	1-1/4"	6"	1
300SB8864	1-3/8"	6"	1
300SB9664	1-1/2"	6"	1

16" Long Spade Wood Drill

Part #	Size	OAL	Qty.
301SB1664	1/4"	16"	1
301SB2464	3/8"	16"	1
301SB3264	1/2"	16"	1
301SB4064	5/8"	16"	1
301SB4864	3/4"	16"	1
301SB5664	7/8"	16"	1
301SB6464	1"	16"	1
301SB8864	1-3/8"	16"	1



5/8"



Quick Insert / Quick Spring
 Out Chuck Extensions.
 SOLD INDIVIDUALLY.



IMPACT
 1/4" HEX IMPACT SHANK

- ◆ 1/4" Hex Impact Shank
- ◆ Quick-Change
- ◆ 1 PC. Construction
- ◆ Industrial Quality
- ◆ Sold Individually

Extension - For Spade Bit

Part #	Size	For Shank	Ø
EXT-300	1/4" x 12"	1/4"	5/8"
EXT-500	1/4" x 18"	1/4"	5/8"

1/4" Extensions - Drill Diameter Must Be Larger Than 5/8".

Self Feed (Multispur) Wood Drill

Part #	Size	MM	Pipe Entrance	Tubing Entrance	Cutting Flute	Shank
306ST-1	1"	25.4	1/2"	7/8"	1"	7/16"
306ST-2	1-1/8"	28.6	1/2"	1"	1"	7/16"
306ST-3	1-1/4"	31.8	3/4"	1-1/8"	1"	7/16"
306ST-4	1-3/8"	34.9	1"	1-1/4"	1"	7/16"
306ST-5	1-1/2"	38.1	1"	1-3/8"	1"	7/16"
306ST-6	1-3/4"	44.5	1-1/4"	1-1/2"	1"	7/16"
306ST-7	2"	50.8	1-1/2"	1-7/8"	1"	7/16"
306ST-8	2-1/8"	54.0	1-1/2"	2"	1"	7/16"
306ST-9	2-1/4"	57.2	1-1/2"	2-1/8"	1"	7/16"
306ST-10	2-9/16"	65.1	2"	2-1/2"	1"	7/16"
306ST-11	3"	76.2	2-1/2"	2-7/8"	2"	7/16"
306ST-12	3-5/8"	92.1	3"	3-1/2"	2"	7/16"
306ST-13	4-5/8"	117.5	4"	4-1/2"	2"	7/16"



Replacement Screw Points

Part #	Size	Fits
SP0001	1/4"	1-1/4" to 2-9/16"
SP0002	1/4"	3" to 4-5/8"

Screw Points come with replacement set screw and wrench.



Wood Plywood

- ◆ 7/16" Hex Impact Shank
- ◆ Fast Continuous and Self Feeding
- ◆ Deep Holes
- ◆ Double End Screw
- ◆ Extra Screw & Wrench
- ◆ Industrial Quality
- ◆ Plumbing
- ◆ Rough In Work



1/2" DRILL



IMPACT DRIVER

SOLD INDIVIDUALLY
1 PER TUBE.



Extensions for Ship Auger & Multispur

POWER BIT EXTENSIONS

Part #	Size	For Shank	Ø	Part #	Size	For Shank	Ø
307BT5618	5/16" x 18"	5/16"	11/16"	307HEX-1	7/16" x 9-1/2"	7/16"	7/8"
				307HEX-2	7/16" x 12"	7/16"	7/8"
				307HEX-3	7/16" x 18"	7/16"	7/8"
				307HEX-4	7/16" x 24"	7/16"	7/8"

5/16" Extensions - Drill Diameter Must Be Larger Than 11/16".
7/16" Extensions - Drill Diameter Must Be Larger Than 7/8".



1/2" DRILL



IMPACT DRIVER



Wood

Timber



CCA Poles

Railroad Ties

- ◆ 7/16" Hex Impact Shank
- ◆ Carbide Tipped
- ◆ Hex Shank
- ◆ Heat Treated
- ◆ Machine Ground Hollows
- ◆ Deep Throat
- ◆ Single Twist
- ◆ Single Cutter
- ◆ Side Lip
- ◆ Power Groove
- ◆ Self-Feeding Screw Point



1/2" DRILL



IMPACT DRIVER



AUSTRIA

SOLD INDIVIDUALLY
1 PER POUCH.

**CHECK STOCK
BEFORE ORDERING!**

**POWER POLE DRILLS
ARE SUBJECT
TO AVAILABILITY.**

Power Pole Auger Wood Drills

Part #	Size	OAL	Drilling	Shank
CPP-11121	1/2"	18"	15"	7/16"
CPP-12122	1/2"	24"	21"	7/16"
CPP-13123	1/2"	36"	33"	7/16"
CPP-14911	9/16"	18"	15"	7/16"
CPP-15912	9/16"	24"	21"	7/16"
CPP-16913	9/16"	36"	33"	7/16"
CPP-17581	5/8"	18"	15"	7/16"
CPP-18582	5/8"	24"	21"	7/16"
CPP-19583	5/8"	36"	33"	7/16"
CPP-20161	11/16"	18"	15"	7/16"
CPP-21162	11/16"	24"	21"	7/16"
CPP-22163	11/16"	36"	33"	7/16"
CPP-23241	3/4"	18"	15"	7/16"
CPP-24342	3/4"	24"	21"	7/16"
CPP-25343	3/4"	36"	33"	7/16"
CPP-26131	13/16"	18"	15"	7/16"
CPP-27132	13/16"	24"	21"	7/16"
CPP-28133	13/16"	36"	33"	7/16"
CPP-28648	13/16"	48"	45"	7/16"
CPP-29781	7/8"	18"	15"	7/16"
CPP-30782	7/8"	24"	21"	7/16"
CPP-31783	7/8"	36"	33"	7/16"
CPP-32561	15/16"	18"	15"	7/16"
CPP-33562	15/16"	24"	21"	7/16"
CPP-34563	15/16"	36"	33"	7/16"
CPP-34648	15/16"	48"	45"	7/16"
CPP-35115	1"	18"	15"	7/16"
CPP-36121	1"	24"	21"	7/16"
CPP-37133	1"	36"	33"	7/16"
CPP-38135	1-1/16"	24"	21"	7/16"
CPP-39136	1-1/16"	36"	33"	7/16"
CPP-40137	1-1/16"	48"	45"	7/16"

Use with 1/2" Drills or Impact Drivers:

- Stanley ID-04 "Yellow Jacket"
- Racine HIW-716
- Fairmount H8508

Also works well in heavy duty electric, pneumatic, and gas powered drills.

Power Pole Auger Drill Bits are carbide tipped wood drill bits that have a carbide-tipped cutting tip combined with a hardened steel cutting edge. These unique carbide tipped wood drill bits bore holes in all types of wood quickly, leaving little or no residue. A truly clean, smooth hole is produced. Power Pole carbide tipped wood auger drill bits require less torque to operate and can be used with electric, air, or gasoline powered drill motors and impact wrenches.

Made of premium steel, Power Pole Auger Bits are for boring CCA and Creosoted poles, railroad ties, bulkheads, and other heavy timber.



8" Long Ship Auger Wood Drill

Part #	Size	Size In 16ths	OAL	Hex Shank
302SL3264	1/2"	8	8"	7/16"
302SL3664	9/16"	9	8"	7/16"
302SL4064	5/8"	10	8"	7/16"
302SL4464	11/16"	11	8"	7/16"
302SL4864	3/4"	12	8"	7/16"
302SL5264	13/16"	13	8"	7/16"
302SL5664	7/8"	14	8"	7/16"
302SL6064	15/16"	15	8"	7/16"
302SL6464	1"	16	8"	7/16"
302SL7264	1-1/8"	18	8"	7/16"
302SL8064	1-1/4"	20	8"	7/16"
302SL8864	1-3/8"	22	8"	7/16"
302SL9664	1-1/2"	24	8"	7/16"



- ◆ 7/16" Hex Impact Shank
- ◆ 6" Twist Length
- ◆ Heat Treated
- ◆ Deep Throat
- ◆ Single Twist
- ◆ Single Cutter
- ◆ Side Lip
- ◆ Self-Feeding Screw Point



JAM FREE FLUTE



AUSTRIA

SOLD INDIVIDUALLY
1 PER POUCH.



18" Long Ship Auger Wood Drill

Part #	Size	Size In 16ths	OAL	Hex Shank
303SL2464	3/8"	6	18"	7/16"
303SL2864	7/16"	7	18"	7/16"
303SL3264	1/2"	8	18"	7/16"
303SL3664	9/16"	9	18"	7/16"
303SL4064	5/8"	10	18"	7/16"
303SL4464	11/16"	11	18"	7/16"
303SL4864	3/4"	12	18"	7/16"
303SL5264	13/16"	13	18"	7/16"
303SL5664	7/8"	14	18"	7/16"
303SL6064	15/16"	15	18"	7/16"
303SL6464	1"	16	18"	7/16"
303SL7264	1-1/8"	18	18"	7/16"
303SL8064	1-1/4"	20	18"	7/16"
303SL8864	1-3/8"	22	18"	7/16"
303SL9664	1-1/2"	24	18"	7/16"



- ◆ 7/16" Hex Impact Shank
- ◆ 15" Twist Length
- ◆ Heat Treated
- ◆ Deep Throat
- ◆ Single Twist
- ◆ Single Cutter
- ◆ Side Lip
- ◆ Self-Feeding Screw Point

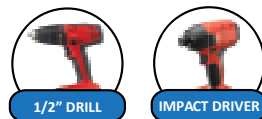

JAM FREE FLUTE



AUSTRIA

SOLD INDIVIDUALLY
1 PER POUCH.



7" Sharpening File - Ship Augers

Part #	Description
303SL-F1	7" Sharpening File

Files are specially designed to sharpen your valuable auger bits for a longer cutting life. These files feature one end single cut with safe edges (uncut) and one end safe (uncut) with single cut edges.



V GROOVE Tile Bit - Skin Card

Part #	Size	X	OAL	Drilling	Shank	Qty.
VG-4001	1/8"	X	3"	2"	1/8"	1
VG-3002	3/16"	X	3"	2"	3/16"	1
VG-4002	3/16"	X	4"	2-3/4"	3/16"	1
VG-6001	3/16"	X	6"	4-1/4"	3/16"	1
VG-4003	1/4"	X	4"	2-3/4"	1/4"	1
VG-6002	1/4"	X	6"	4-1/4"	1/4"	1
VG-6003	5/16"	X	6"	4-1/4"	5/16"	1
VG-6004	3/8"	X	6"	4-1/4"	3/8"	1
VG-6716	7/16"	X	6"	4-1/4"	3/8"	1
VG-6005	1/2"	X	6"	4-1/4"	3/8"	1

- ◆ 20 Holes Drilled In Grade 5 Porcelain Tile
- ◆ Precision Design
- ◆ Unique Carbide Head
- ◆ Carbide Serrations



Rotation Only! USE WATER



PULSE & PUSH™
 Method of Drilling

1. Pulse the drill and apply pressure.
2. Repeat this step 3 times.
3. Dip carbide tip in water. Repeat **PULSE & PUSH™** until hole is drilled.



20 Holes Drilled In Porcelain Tile Video
 Take a Picture of QR Code



V GROOVE Tile Bit - Bulk Pack

Part #	Size	X	OAL	Drilling	Shank	Qty.
VG-4001B	1/8"	X	3"	2"	1/8"	25
VG-3002B	3/16"	X	3"	2"	3/16"	25
VG-4002B	3/16"	X	4"	2-3/4"	3/16"	25
VG-6001B	3/16"	X	6"	4-1/4"	3/16"	25
VG-4003B	1/4"	X	4"	2-3/4"	1/4"	25
VG-6002B	1/4"	X	6"	4-1/4"	1/4"	25
VG-6003B	5/16"	X	6"	4-1/4"	5/16"	25

Unique Carbide Head Design



No Walk Carbide Point.

Carbide Serrations To Evacuate Fine Dust.





V GROOVE™

BATHROOM FIXTURE INSTALL KIT

V GROOVE Kit - Stainless Pan Head Screws

Part #	Description	Drill Bit	Anchor	Screw
VGK-1	3/16" Install Kit	3/16" x 4"	3/16" x 7/8"	#8 x 1"
VGK-2	3/16" Install Kit	3/16" x 4"	3/16" x 7/8"	#8 x 1-1/2"
VGK-3	1/4" Install Kit	1/4" x 4"	1/4" x 1"	#10 x 1"
VGK-4	1/4" Install Kit	1/4" x 4"	1/4" x 1"	#10 x 1-1/2"



V GROOVE Tile Bits (5)



#2 x 2" Phillips® Insert Bit (1)



Conical Anchors (50)



Phillips® Pan Head Stainless Screws (50)



BATH
•
SHOWER
•
KITCHEN

V GROOVE Kit - Stainless Flat Head Screws

Part #	Description	Drill Bit	Anchor	Screw
VGK-1F	3/16" Install Kit	3/16" x 4"	3/16" x 7/8"	#8 x 1"
VGK-2F	3/16" Install Kit	3/16" x 4"	3/16" x 7/8"	#8 x 1-1/2"
VGK-3F	1/4" Install Kit	1/4" x 4"	1/4" x 1"	#10 x 1"
VGK-4F	1/4" Install Kit	1/4" x 4"	1/4" x 1"	#10 x 1-1/2"



V GROOVE Tile Bits (5)



#2 x 2" Phillips® Insert Bit (1)



Conical Anchors (50)



Phillips® Flat Head Stainless Screws (50)



V SCREW - 101 Pcs. Stainless Pan Head Screws

Part #	Description	Anchor	Qty.	Screw
VS-1	#8 x 1" Pan Head	3/16"	101	Phillips®
VS-2	#8 x 1-1/2" Pan Head	3/16"	101	Phillips®
VS-3	#10 x 1" Pan Head	1/4"	101	Phillips®
VS-4	#10 x 1-1/2" Pan Head	1/4"	101	Phillips®



V SCREW - 101 Pcs. Stainless Flat Head Screws

Part #	Description	Anchor	Qty.	Screw
VS-1F	#8 x 1" Flat Head	3/16"	101	Phillips®
VS-2F	#8 x 1-1/2" Flat Head	3/16"	101	Phillips®
VS-3F	#10 x 1" Flat Head	1/4"	101	Phillips®
VS-4F	#10 x 1-1/2" Flat Head	1/4"	101	Phillips®



V SCREW - 101 Pcs. Conical Anchors

Part #	Description	Anchor	Qty.	Screw
VAC-1	Conical Anchor	3/16" x 7/8"	101	#8
VAC-3	Conical Anchor	1/4" X 1"	101	#10



V SCREW™

101 Pcs. STAINLESS STEEL SCREWS



#2 X 2" PHILLIPS INCLUDED IN EVERY V SCREW TUBE. EXTRAS ON P.126



For Wet Environments...
GET ONE MORE SCREW



WHITE DIAMOND



IMPACT
 1/4" HEX IMPACT SHANK



White Diamond Tile Bit - 1/4" Hex Shank

Part #	Size	X	OAL	Drilling	Qty.
HEX-12	3/16"	X	2-5/8"	1-1/4"	1
HEX-14	1/4"	X	2-5/8"	1-1/4"	1
HEX-16	5/16"	X	3-1/8"	1-1/4"	1
HEX-18	3/8"	X	3-1/8"	1-1/4"	1
HEX-20	1/2"	X	3-1/8"	1-1/4"	1
HEX-22	5/8"	X	2-3/4"	1-1/4"	1
HEX-24	3/4"	X	2-3/4"	1-1/4"	1
HEX-26	7/8"	X	2-3/4"	1-1/4"	1
HEX-28	1"	X	2-3/4"	1-1/4"	1

- ◆ 1/4" Hex Impact Shank
- ◆ Dry Cutting
- ◆ Vacuum Brazed Diamond
- ◆ Wax Filled For Lubrication up To 1/2" Diameter

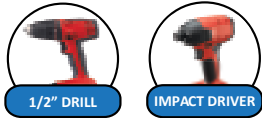

White Diamond Tile Bit - 5/8"-11 Thread

Part #	Size	X	OAL	Drilling	Qty.
ANG-26	7/8"	X	2-3/8"	1-1/4"	1
ANG-28	1"	X	2-3/8"	1-1/4"	1
ANG-30	1-1/8"	X	2-3/8"	1-1/4"	1
ANG-32	1-1/4"	X	2-3/8"	1-1/4"	1
ANG-34	1-3/8"	X	2-3/8"	1-1/4"	1
ANG-36	1-1/2"	X	2-3/8"	1-1/4"	1
ANG-38	2"	X	2-3/8"	1-1/4"	1
ANG-40	2-1/2"	X	2-3/8"	1-1/4"	1

- ◆ Dry Cutting
- ◆ Vacuum Brazed Diamond
- ◆ 5/8"-11 Thread



Wax Filled For Lubrication Up To 1/2" Diameter

Vacuum Brazed Diamond



5/8"-11 Adapter
 P. 83

WHITE DIAMOND



Diamond Milling Cutter

Part #	Size	OAL	Qty.
DMC-6	1/4"	2-7/8"	1
DMC-8	5/16"	2-7/8"	1
DMC-10	3/8"	2-7/8"	1
DMC-16	5/8"	2-7/8"	1
DMC-20	3/4"	2-7/8"	1
DMC-25	1"	2-7/8"	1
DMC-50	2"	2-7/8"	1
DMC-75	3"	2-7/8"	1



- ◆ Vacuum Brazed Diamond
- ◆ 5/8"-11 Thread
- ◆ Wet or Dry Cutting
- ◆ #45/50 Diamond Grit
- ◆ Milling Inside Circle Or Half Circle For Pipe

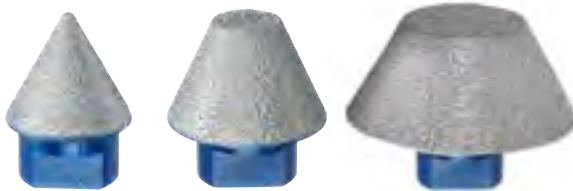

POINT-1 POINT-2 POINT-3

Diamond Countersink

Part #	Size	Qty.
POINT-1	Hole Sizes - 3/16" - 1-3/8"	1
POINT-2	Hole Sizes - 1" - 1-7/8"	1
POINT-3	Hole Sizes - 1-7/8" - 3"	1



- ◆ Vacuum Brazed Diamond
- ◆ 5/8"-11 Thread
- ◆ Wet or Dry Cutting
- ◆ #45/50 Diamond Grit
- ◆ Cleaning Rough Edges On Drilled Circle Holes



Point Adapter

Part #	Size	Qty.
PAD-5811	Point Adapter (5/8"-11)	1



- ◆ Fits Diamond Milling / Countersink / Holesaw
- ◆ 5/8"-11 Thread
- ◆ 3/8" Shank





GLASS DRILL

ROTATION ONLY
 Fast drilling speeds and lubricant are recommended when using these drills.

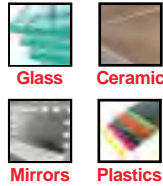

Glass Drills - STANDARD TIP

Part #	Size	OAL	Shank
GL-0864	1/8"	2-1/4"	1/8"
GL-1264	3/16"	2-3/4"	3/16"
GL-1664	1/4"	3"	1/4"
GL-2064	5/16"	3-1/4"	1/4"
GL-2464	3/8"	3-1/2"	3/8"
GL-3264	1/2"	4"	3/8"

Glass Drills - Bulk 25 Pack

Part #	Size	OAL	Shank
GL-1264B	3/16"	2-3/4"	3/16"
GL-1664B	1/4"	3"	1/4"

ANSI ♦ Tungsten Carbide Tip



USE WATER



Glass Drills - QUAD-CUTTER

Part #	Size	OAL	Shank
QG-0012	3/16"	2-3/4"	3/16"
QG-0014	1/4"	3"	1/4"
QG-0016	5/16"	3-1/4"	1/4"
QG-0018	3/8"	3-1/2"	3/8"
QG-0020	1/2"	4"	3/8"

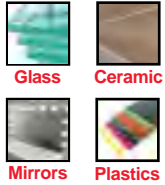

- ♦ Tungsten Carbide Tip
- ♦ Sold Individually



Glass Drills - RAZOR CUTTER

Part #	Size	OAL	Shank
RAZ-4001	1/8"	3"	1/8"
RAZ-4002	3/16"	3"	3/16"
RAZ-4003	1/4"	4"	1/4"
RAZ-4004	5/16"	4"	1/4"
RAZ-4005	3/8"	4"	5/16"
RAZ-4006	1/2"	4"	3/8"

Glass Drills - Bulk 25 Pack

Part #	Size	OAL	Shank
RAZ-4002B	3/16"	3"	3/16"
RAZ-4003B	1/4"	4"	1/4"



- ♦ Diamond Segments
- ♦ Wet Drilling
- ♦ Core Extraction
- ♦ Rotation Only
- ♦ Sold Individually



Blu Diamond Tile Bit

Part #	Size	OAL	Shank
BLU-1	1/4"	2"	3/8"
BLU-3	5/16"	2"	3/8"
BLU-4	3/8"	2-1/2"	3/8"
BLU-5	1/2"	2-1/2"	3/8"
BLU-6	3/4"	2-3/4"	3/8"
BLU-8	1"	2-3/4"	3/8"



Part # RAZ-SET5
5 Pc. RAZOR
Glass Drill Set
 1/8", 3/16", 1/4", 3/8", 1/2"





ANSI

Multi Purpose Drills - CARBIDE TIP

Part #	Size	OAL	Drilling	Shank
600CD0864	1/8"	3"	1-1/2"	1/8"
600CD1064	5/32"	3-1/8"	1-3/4"	5/32"
600CD1264	3/16"	3-1/2"	2-3/16"	3/16"
600CD1664	1/4"	4-1/8"	2-9/16"	1/4"
600CD2064	5/16"	4-3/4"	3-5/32"	5/16"
600CD2464	3/8"	6"	4-3/8"	3/8"
600CD3264	1/2"	6-3/4"	4"	1/2"
600CD4064	5/8"	6"	4"	1/2"



ROTATION ONLY
Moderate drilling speeds and lubricant are recommended when using these drills.

- ◆ Multi Purpose
- ◆ Tungsten Carbide
- ◆ Turbo Flute
- ◆ Straight Shank
- ◆ ANSI Specification
- ◆ Sold Individually



Hard Steel Drill - Left Hand

Part #	Size	X	OAL	Shank
LHB-18	1/8"	X	3"	1/8"
LHB-20	3/16"	X	3"	3/16"
LHB-22	1/4"	X	4"	1/4"
LHB-26	5/16"	X	4"	1/4"
LHB-32	3/8"	X	6"	3/8"
LHB-50	1/2"	X	6"	1/2"



Hard Steel Drill - Right Hand

Part #	Size	X	OAL	Shank
RHB-18	1/8"	X	3"	1/8"
RHB-20	3/16"	X	3"	3/16"
RHB-22	1/4"	X	4"	1/4"
RHB-26	5/16"	X	4"	1/4"
RHB-32	3/8"	X	6"	3/8"
RHB-50	1/2"	X	6"	1/2"

ANSI



- ◆ Safes
- ◆ Broken Bolts
- ◆ Carbide Tip
- ◆ Tempered Body
- ◆ ANSI B212.15-1994
- ◆ Sold Individually



Part # LHB-SET5
5 Pc. Left Hand Hard Steel Drill Set
1/8", 3/16", 1/4", 5/16", 3/8"



Part # RHB-SET5
5 Pc. Right Hand Hard Steel Drill Set
1/8", 3/16", 1/4", 5/16", 3/8"

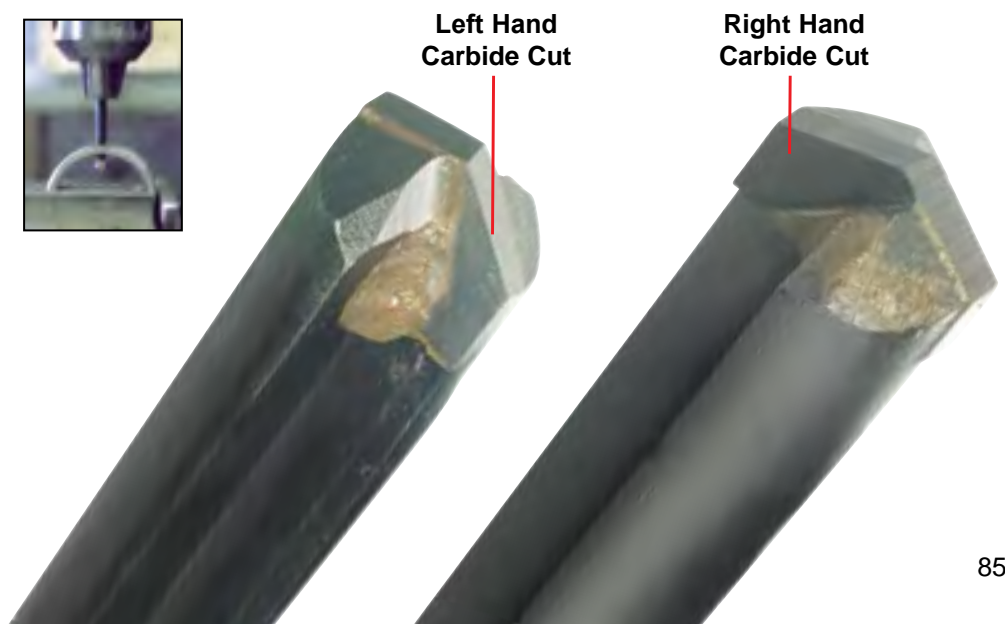
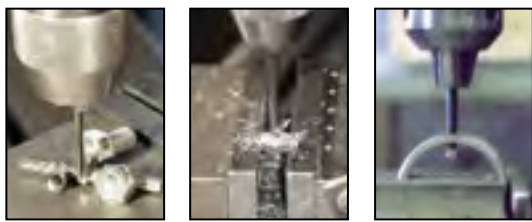



STRAIGHT SHANK



ANSI

Slow Spiral Masonry Drills

Part #	Size	X	OAL	Drilling	Shank
502SP4001	1/8"	X	3"	1-1/2"	1/8"
502SP4002	3/16"	X	4"	2-1/2"	3/16"
502SP6001	3/16"	X	6"	4"	3/16"
502SP4732	7/32"	X	4"	2-1/2"	7/32"
502SP4003	1/4"	X	4"	2-1/2"	1/4"
502SP6002	1/4"	X	6"	4"	1/4"
502SP1201	1/4"	X	12"	10"	1/4"
502SP1814	1/4"	X	18"	16"	1/4"
502SP4004	5/16"	X	4"	2-1/2"	1/4"
502SP6003	5/16"	X	6"	4"	1/4"
502SP4005	3/8"	X	4"	2-1/2"	1/4"
502SP6004	3/8"	X	6"	4"	3/8"
502SP1203	3/8"	X	12"	10"	3/8"
502SP1838	3/8"	X	18"	16"	3/8"
502SP6005	7/16"	X	6"	4"	1/4"
502SP4006	1/2"	X	4"	2-1/2"	1/4"
502SP6007	1/2"	X	6"	4"	3/8"
502SP1204	1/2"	X	12"	10"	3/8"
502SP1812	1/2"	X	18"	16"	3/8"
502SP6008	9/16"	X	6"	4"	3/8"
502SP6009	5/8"	X	6"	4"	3/8"
502SP1205	5/8"	X	12"	10"	3/8"
502SP1858	5/8"	X	18"	16"	3/8"
502SP6010	3/4"	X	6"	4"	1/2"
502SP1206	3/4"	X	12"	10"	1/2"
502SP1834	3/4"	X	18"	16"	1/2"
502SP6011	7/8"	X	6"	4"	1/2"
502SP1207	7/8"	X	12"	10"	1/2"
502SP1878	7/8"	X	18"	16"	1/2"
502SP6012	1"	X	6"	4"	1/2"
502SP1208	1"	X	12"	10"	1/2"
502SP1801	1"	X	18"	16"	1/2"

Use with Rotation or Percussion



Cinderblock Brick Concrete Masonry

- ◆ General Purpose
- ◆ Tungsten Carbide
- ◆ Slow Spiral Flute
- ◆ Tempered Body
- ◆ Black Oxide Finish
- ◆ Gold Head
- ◆ Straight Shank
- ◆ ANSI Specification



1/2" DRILL



HAMMER DRILL

A first generation carbide tipped drill bit, mass produced since the early 1970's, first in Europe, then in Puerto Rico, then in the USA. Still used ubiquitously and found in anchor kits all over the world.

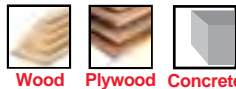
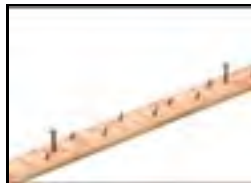

- ◆ Carbide Tip
- ◆ Bright Finish
- ◆ For Tack Strip



1/2" DRILL



Carpet Stub Drills

Part #	Size	OAL	Qty.
CD-18	1/8"	1-7/8"	1
CD-18L	1/8"	2-3/4"	1



Roto Percussion Drills - Super Shlager

Part #	Size	X	OAL	Drilling	Shank
700040864	1/8"	X	3"	1-1/2"	1/8"
700061064	5/32"	X	6"	4"	5/32"
700041264	3/16"	X	3-1/2"	1-3/4"	3/16"
700061264	3/16"	X	6"	4"	3/16"
700061464	7/32"	X	6"	4"	7/32"
700041664	1/4"	X	4"	2-1/2"	1/4"
700061664	1/4"	X	6"	4"	1/4"
700081664	1/4"	X	12"	10"	1/4"
700024166	1/4"	X	24"	20"	1/4"
700042064	5/16"	X	4-3/4"	3-1/2"	5/16"
700062064	5/16"	X	6"	4"	5/16"
700062464	3/8"	X	6"	4"	3/8"
700082464	3/8"	X	12"	10"	3/8"
700020246	3/8"	X	20"	16"	3/8"
700024246	3/8"	X	24"	20"	3/8"
700063264	1/2"	X	6"	4"	3/8"
700083264	1/2"	X	12"	10"	3/8"
700020326	1/2"	X	20"	16"	3/8"
700024326	1/2"	X	24"	20"	3/8"
700064064	5/8"	X	6"	4"	Hex 3/8"
700084064	5/8"	X	12"	10"	Hex 3/8"
700024406	5/8"	X	24"	20"	Hex 1/2"
700064864	3/4"	X	6"	4"	Hex 1/2"
700084864	3/4"	X	12"	10"	Hex 1/2"
700024034	3/4"	X	24"	20"	Hex 1/2"
700065664	7/8"	X	6"	4"	Hex 1/2"
700066464	1"	X	6"	4"	Hex 1/2"



Use with Percussion



Cinderblock Brick Concrete Masonry

- ◆ Heavy Duty
- ◆ Percussion Grade Tungsten Carbide
- ◆ Unique Spiral Flute for Fast Dust Removal
- ◆ Heat Treated Body
- ◆ Polished Finish
- ◆ Hex Shank on Larger Diameters to Prevent Slipping
- ◆ ANSI Specification



HAMMER DRILL



SOLD INDIVIDUALLY
1 PER TUBE.



These Drill Bits are made for machines with percussion. They will not perform with rotation only.

**Made For
Hammer Drills!**



SDS-PLUS ROTARY HAMMER DRILLS



Chisel Shaped Head Geometry - Fast Penetration
 High Volume Flute - Fast Dust Removal



REDLINE P. 90-91

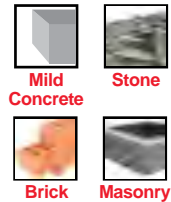

◆ ANSI Specification



Serrated Head Geometry and Self Centering Tip - Easy Spot Drilling
 Web Shaped Head - Improved Dust Release to Flute
 High Volume Flute - Faster Debris Removal
 Flute Core Reinforcement - Reduces Vibrations
 Rebar Chamfers - Prevents Carbide From Cracking When in Contact with Rebar



BOHR HAMMER P. 92-95



◆ ANSI Specification
 ◆ Made in Germany



4 x 90° Serrated Tip Carbide Head - Crushes Through and Prevents Sticking in Rebar
 High Helix Geometry Flute - For Torsional Stress and Getting Debris to Flute
 Rebar Chamfers - Prevents Carbide From Cracking When in Contact With Rebar
 4 Fluted Geometry - Evenly Distributes Flute Load for Less Flute Wear
 Maximum Core Reinforcement - Reduces Vibrations



eVolution P. 96

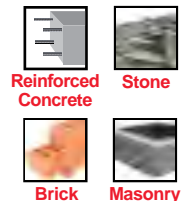

◆ ANSI Specification
 ◆ Made in Germany



4 x 90° X-Cutter Carbide Head - Crushes Through and Prevents Sticking in Rebar
 Wear Mark Indicator - Ensures Dimensional Hole Accuracy
 Rebar Chamfers - Prevents Carbide From Cracking When in Contact With Rebar
 More Carbide Mass - Extra Carbide Compared to Bohr Hammer
 Flute Core Reinforcement - Reduces Vibrations



X-CUTTER P.97

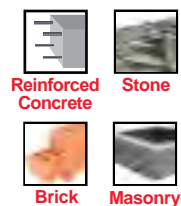

◆ ANSI Specification
 ◆ Made in Germany

SDS-PLUS ROTARY HAMMER DRILL MACHINES

BOSCH	DEWALT	HILTI	HITACHI	MAKITA	MILWAUKEE	METABO
11207	D25012K	TE 1	DH18DL	BHR202	0756-22	6010
11210	D25023K	TE 2	DH22PG	BHR241	2412-20	6011
11211	D25111K	TE 2-A	DH24	HR160	2416-20XC	6015
11212	D25123K	TE 2-A18	DH24PF3	HR1821	2605-20	6018
11215	D25133K	TE 2-M	DH25	HR1830	2612-22	6020
11524	D25211K	TE 2-S	DH28	HR1830F	2712-22	6021
11213RK	D25213K	TE 4-A18	DH28PC	HR2000	2715-22	6024
11221DVS	D25223K	TE 4-A22	DH28PD	HR2010	5262	6026
11222EVS/G	D25211K	TE 6-A36-AVR	DH30	HR2400	5262-21	6028
11224VSR	D25213K	TE 6-S	H30PV	HR2410	5263	BHA18
11225VSR/H	D25223K	TE 7	VR16	HR2420	5263-21	BHE22
11228VSR	D25260K	TE 7-A	VRT22	HR2431	5268-21	BHE2243
11234VSR	D25262K	TE 7-C		HR2432	5302	BHE24
11236VS	D25263K	TE 30		HR2450	5303	BHE2444
11239VS	D25313K	TE 30-A36		HR2455	5312	BHE2644
11250VSR	D25323K	TE 30-C-AVR		HR2470F	5320	BHE6015
11250VSRD	D25324K	TE 30-M-AVR		HR2475	5324	KHE24
11253VSR	D25404K	TE 40		HR2511	5342	KHE2444
11255VSR	D25413K	TE 40-AVR		HR2611F	5359	KHE2640
11536C-1(2)	D25416K	TE A-36AVR		HR2621	5359-21	KHE2644
11536VSR		TE/GP 22		HR2811F	5360	KHE3650
RH228VC				HR3000C	5362	KHE28
RH328VC(Q)				HR3210C	5363	KHE2851
RH432VC(Q)					5363-21	KHE32
RHH181-01					5365	KHE3250
RHH181BL					5366	KHE3251
RHS181B					5368	UHE22
RHS181K					5369	UHE2250
					5383	UHE2450
					V28	UHE2650
						UHE28
						UHE2850



SDS-MAX ROTARY HAMMER DRILL MACHINES

BOSCH	DEWALT	HILTI	HITACHI	MAKITA	MILWAUKEE	METABO
11214EVS	25600K	TE-F 52	DH38MS	HR4000C	5308	6045
1223	2570K	TE-F 60	DH40MA	HR4001C	5313	KHE 5-40
1227	541K	TE-F 72	DH40MB	HR4002	5314	KHE56
1230	545K	TE-F 92	DH40MRY	HR4002C	5315	KHE76
11216	D25501K	TE-Y 54	DH45MR	HR4010C	5317	KHE96
11231	D25601K	TE-Y 55	DH50MRY	HR4013C	5317-21	
11235	D25602K	TE-Y 56	H60HR	HR4500C	5342	
11240	D25603K	TE-Y 70		HR4510C	5342-21	
11241	D25712K	TE-Y 74		HR5001C	5346	
11245	D25721K	TE-Y 75		HR5210C	5426	
11245EVS	D25723K	TE-Y 76		HR5212C	5426-1	
11263	D25761K	TE50			5446	
11263EVS	D25762K	TE60				
11264	D25763K	TE60-ATC/AVR				
11264EVS		TE70				
RH540M		TE70-ATC/AVR				
RH745		TE80-ATC/AVR				
RH850VC						



SPLINE DRIVE ROTARY HAMMER DRILL MACHINES

BOSCH	DEWALT	HILTI	HITACHI	MAKITA	MILWAUKEE	METABO
11202	D25651K	N/A	DH38YE2	HR3851	5309	N/A
11203	D25553K		DH40FR	HR4040C	5311	
11204	530K		DS50SBK	HR4041C	5316	
11205	531K			HR5000	5316-21	
11209	532K				5317	
11214	533K				5318	
11219					5319	
11220					5321	
11232					5340-21	
11233					5341	
11247					5343	
11248					5344	
11244E					5347	
11265EVS					5348	
RH540S					5352	
					5345	

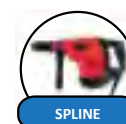



REDLINE 2 - CUTTER

SDS-PLUS Rotary Hammer Drills



For **General Purpose**.
 Rotary Hammer Drilling.



Mild
Concrete



Stone



Brick



Masonry

- ◆ Rotary Hammer Drill
- ◆ 2-Cutter Carbide Head
- ◆ ANSI Specification
- ◆ Sold With Clip or Pro Pack



Part #	Size	X	OAL	Drilling	Qty.
RL-41064	5/32"	X	4-1/4"	2"	1
RL-61064	5/32"	X	6-1/4"	4"	1
RL-61064-B	5/32"	X	6-1/4"	4"	25
RL-41264	3/16"	X	4-1/4"	2"	1
RL-61264	3/16"	X	6-1/4"	4"	1
RL-61264-B	3/16"	X	6-1/4"	4"	25
RL-81264	3/16"	X	8-1/4"	6"	1
RL-81264-B	3/16"	X	8-1/4"	6"	25
RL-41664	1/4"	X	4-1/4"	2"	1
RL-41664-B	1/4"	X	4-1/4"	2"	25
RL-61664	1/4"	X	6-1/4"	4"	1
RL-61664-B	1/4"	X	6-1/4"	4"	25
RL-81664	1/4"	X	8-1/4"	6"	1
RL-81664-B	1/4"	X	8-1/4"	6"	25
RL-62064	5/16"	X	6-1/4"	4"	1
RL-62064-B	5/16"	X	6-1/4"	4"	25
RL-62464	3/8"	X	6-1/4"	4"	1
RL-62464-B	3/8"	X	6-1/4"	4"	25
RL-12038	3/8"	X	12-1/4"	10"	1
RL-12038-B	3/8"	X	12-1/4"	10"	20
RL-63264	1/2"	X	6-1/4"	4"	1
RL-63264-B	1/2"	X	6-1/4"	4"	25
RL-12012	1/2"	X	12-1/4"	10"	1
RL-12012-B	1/2"	X	12-1/4"	10"	10
RL-63664	9/16"	X	6-1/4"	4"	1
RL-84064	5/8"	X	8-1/4"	6"	1
RL-84064-B	5/8"	X	8-1/4"	6"	10
RL-12058	5/8"	X	12"	10"	1
RL-84864	3/4"	X	8"	6"	1
RL-84864-B	3/4"	X	8"	6"	10
RL-12034	3/4"	X	12"	10"	1
RL-12034-B	3/4"	X	12"	10"	5
RL-85664	7/8"	X	8"	6"	1
RL-85664-B	7/8"	X	8"	6"	5
RL-12078	7/8"	X	12"	10"	1
RL-12078-B	7/8"	X	12"	10"	5
RL-10001	1"	X	10"	8"	1
RL-10001-B	1"	X	10"	8"	5

REDLINE X-CUTTER



SDS-PLUS Rotary Hammer Drills

Part #	Size	X	OAL	Drilling	Qty.
FLX-61264	3/16"	X	6-1/4"	4"	1
FLX-61264-B	3/16"	X	6-1/4"	4"	25
FLX-61664	1/4"	X	6-1/4"	4"	1
FLX-61664-B	1/4"	X	6-1/4"	4"	25
FLX-62464	3/8"	X	6-1/4"	4"	1
FLX-62464-B	3/8"	X	6-1/4"	4"	25
FLX-63264	1/2"	X	6-1/4"	4"	1
FLX-63264-B	1/2"	X	6-1/4"	4"	25
FLX-84864	3/4"	X	8"	6"	1
FLX-10001	1"	X	10"	8"	1



One-Piece Carbide Head. Rotary Hammer Drilling.

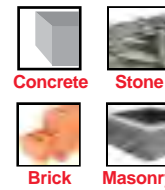

- ◆ Rotary Hammer Drill
- ◆ 1 Pc. X - Cutter
- ◆ ANSI Specification
- ◆ Sold With Clip or Pro Pack



REDLINE CHISELS

SDS-MAX® Chisels

Part #	Size	Description	Qty.
M-012-BP	12"	Bull Point	1
M-024-BP	24"	Bull Point	1
M-112-FC	1" x 12"	Flat Chisel	1
M-124-FC	1" x 24"	Flat Chisel	1
M-212-SC	2" x 12"	Scaling Chisel	1
M-224-SC	2" x 24"	Scaling Chisel	1



Bull Point



Flat Chisel



Scaling Chisel





BOHR HAMMER

SDS-PLUS Rotary Hammer Drills



- ◆ Rotary Hammer Drill
- ◆ Serrated Head Geometry
- ◆ Self Centering Chisel Point
- ◆ ANSI Specification
- ◆ Special Tungsten Carbide Tip
- ◆ Copper / Silver Brazing
- ◆ Fastest Dust Removal
- ◆ Fastest Drilling Speeds
- ◆ Clean Round Holes
- ◆ Less Vibration
- ◆ Polished Finish
- ◆ Industrial Quality



Part #	Size	X	OAL	Drilling	Head	Qty.
715S41064	5/32"	X	4-1/4"	2"	4-PLUS	1
715S61064	5/32"	X	6-1/4"	4"	4-PLUS	1
715S61064-B	5/32"	X	6-1/4"	4"	4-PLUS	25
715S41264	3/16"	X	4-1/2"	2"	4-PLUS	1
715S41264-B	3/16"	X	4-1/2"	2"	4-PLUS	25
715S61264	3/16"	X	6-1/2"	4"	4-PLUS	1
715S61264-B	3/16"	X	6-1/2"	4"	4-PLUS	25
715S81264	3/16"	X	8-1/2"	6"	4-PLUS	1
715S81264-B	3/16"	X	8-1/2"	6"	4-PLUS	25
715S10316	3/16"	X	10-1/2"	8"	4-PLUS	1
715S12316	3/16"	X	12-1/2"	10"	4-PLUS	1
715S14316	3/16"	X	14"	12"	4-PLUS	1
715S16316	3/16"	X	16"	14"	4-PLUS	1
715S20316	3/16"	X	20"	18"	4-PLUS	1
715S24316	3/16"	X	24"	22"	4-PLUS	1
715S41464	7/32"	X	4-1/2"	2"	4-PLUS	1
715S61464	7/32"	X	6-1/2"	4"	4-PLUS	1
715S81464	7/32"	X	8-1/2"	6"	4-PLUS	1
715S10732	7/32"	X	10-1/2"	8"	4-PLUS	1
715S16732	7/32"	X	16"	14"	4-PLUS	1
715S20732	7/32"	X	20"	18"	4-PLUS	1
715S24732	7/32"	X	24"	22"	4-PLUS	1
715S41664	1/4"	X	4-1/2"	2"	4-PLUS	1
715S41664-B	1/4"	X	4-1/2"	2"	4-PLUS	25
715S61664	1/4"	X	6-1/2"	4"	4-PLUS	1
715S61664-B	1/4"	X	6-1/2"	4"	4-PLUS	25
715S81664	1/4"	X	8-1/2"	6"	4-PLUS	1
715S81664-B	1/4"	X	8-1/2"	6"	4-PLUS	25
715S10014	1/4"	X	10-1/2"	8"	4-PLUS	1
715S14014	1/4"	X	14"	12"	4-PLUS	1
715S16014	1/4"	X	16"	14"	4-PLUS	1
715S20014	1/4"	X	20"	18"	4-PLUS	1
715S24014	1/4"	X	24"	22"	4-PLUS	1
715S62064	5/16"	X	6-1/2"	4"	4-PLUS	1
715S62064-B	5/16"	X	6-1/2"	4"	4-PLUS	25
715S82064	5/16"	X	8-1/2"	6"	4-PLUS	1
715S12516	5/16"	X	12-1/2"	10"	4-PLUS	1
715S62464	3/8"	X	6-1/2"	4"	4-PLUS	1
715S62464-B	3/8"	X	6-1/2"	4"	4-PLUS	25
715S82464	3/8"	X	8-1/2"	6"	4-PLUS	1
715S10038	3/8"	X	10-1/2"	8"	4-PLUS	1
715S12038	3/8"	X	12-1/2"	10"	4-PLUS	1
715S12038-B	3/8"	X	12-1/2"	10"	4-PLUS	10
715S18038	3/8"	X	18"	16"	4-PLUS	1
715S24038	3/8"	X	24"	22"	4-PLUS	1
715S62864	7/16"	X	6-1/2"	4"	4-PLUS	1
715S10716	7/16"	X	10-1/2"	8"	4-PLUS	1
715S12716	7/16"	X	12-1/2"	10"	4-PLUS	1
715S18716	7/16"	X	18"	16"	4-PLUS	1

BOHR HAMMER

SDS-PLUS Rotary Hammer Drills

Part #	Size	X	OAL	Drilling	Head	Qty.
715S63264	1/2"	X	6-1/2"	4"	4-PLUS	1
715S63264-B	1/2"	X	6-1/2"	4"	4-PLUS	25
715S10012	1/2"	X	10-1/2"	8"	4-PLUS	1
715S12012	1/2"	X	12-1/2"	10"	4-PLUS	1
715S12012-B	1/2"	X	12-1/2"	10"	4-PLUS	10
715S12018	1/2"	X	18"	16"	4-PLUS	1
715S12024	1/2"	X	24"	22"	4-PLUS	1
715S63664	9/16"	X	6-1/4"	4"	4-PLUS	1
715S10916	9/16"	X	10-1/4"	8"	4-PLUS	1
715S12916	9/16"	X	12-1/4"	10"	4-PLUS	1
715S18916	9/16"	X	18"	16"	4-PLUS	1
715S64064	5/8"	X	6-1/4"	4"	4-PLUS	1
715S84064	5/8"	X	8-1/4"	6"	4-PLUS	1
715S84064-B	5/8"	X	8-1/4"	6"	4-PLUS	10
715S12058	5/8"	X	12-1/4"	10"	4-PLUS	1
715S18058	5/8"	X	18"	16"	4-PLUS	1
715S24058	5/8"	X	24"	22"	4-PLUS	1
715S14464	11/16"	X	12"	10"	4-PLUS	1
715S84864	3/4"	X	8"	6"	4-PLUS	1
715S84864-B	3/4"	X	8"	6"	4-PLUS	10
715S10034	3/4"	X	10"	8"	4-PLUS	1
715S12034	3/4"	X	12"	10"	4-PLUS	1
715S12034-B	3/4"	X	12"	10"	4-PLUS	5
715S18034	3/4"	X	18"	16"	4-PLUS	1
715S24034	3/4"	X	24"	22"	4-PLUS	1
715S85664	7/8"	X	8"	6"	4-PLUS	1
715S85664-B	7/8"	X	8"	6"	4-PLUS	5
715S10078	7/8"	X	10"	8"	4-PLUS	1
715S12078	7/8"	X	12"	10"	4-PLUS	1
715S12078-B	7/8"	X	12"	10"	4-PLUS	5
715S18078	7/8"	X	18"	16"	4-PLUS	1
715S86464	1"	X	8"	6"	4-PLUS	1
715S10001	1"	X	10"	8"	4-PLUS	1
715S10001-B	1"	X	10"	8"	4-PLUS	5
715S12001	1"	X	12"	10"	4-PLUS	1
715S18001	1"	X	18"	16"	4-PLUS	1



4-PLUS

A new, fast and tough serrated carbide tip provides long life, easy centering, and fast drilling through all aggregates, concrete, masonry, brick and natural stone.

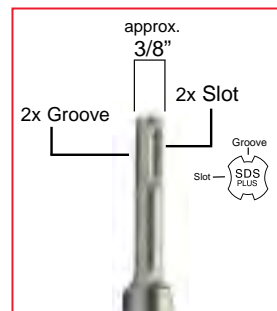

SDS-Plus Machines have chucks with an internal piston and ball-bearing system. This allows the drill bit to rotate and hammer back & forth along the length of the slot.



SDS-PLUS Rotary Hammer - Extra Long

Part #	Size	X	OAL	Drilling	Head	Qty.
715FL3614	1/4"	X	36"	34"	2-CUTTER	1
715FL3638	3/8"	X	36"	34"	2-CUTTER	1
715FL3632	1/2"	X	36"	34"	2-CUTTER	1
715FL3658	5/8"	X	36"	34"	2-CUTTER	1
715FL3634	3/4"	X	36"	34"	2-CUTTER	1





INTERNATIONAL TOOL MANUFACTURING

150 Express St. Plainview, NY 11803

(516) 738-0388 • (800) 247-5696

Fax (516) 279-1106

BOHR HAMMER - BULK DRILLS

SDS-PLUS Rotary Hammer Drills



- ◆ Rotary Hammer Drill
- ◆ Serrated Head Geometry
- ◆ Self Centering Chisel Point
- ◆ ANSI Specification
- ◆ Special Tungsten Carbide Tip
- ◆ Copper / Silver Brazing
- ◆ Fastest Dust Removal
- ◆ Fastest Drilling Speeds
- ◆ Clean Round Holes
- ◆ Less Vibration
- ◆ Polished Finish
- ◆ Industrial Quality

Part #	Size	X	OAL	Drilling	Pack	Min.Qty.
715B41064	5/32"	X	4-1/4"	2"	BULK	50
715B61064	5/32"	X	6-1/4"	4"	BULK	50
715B41264	3/16"	X	4-1/2"	2"	BULK	50
715B61264	3/16"	X	6-1/2"	4"	BULK	100
715B81264	3/16"	X	8-1/2"	6"	BULK	50
715B10316	3/16"	X	10-1/2"	8"	BULK	25
715B12316	3/16"	X	12-1/2"	10"	BULK	25
715B14316	3/16"	X	14"	12"	BULK	25
715B16316	3/16"	X	16"	14"	BULK	25
715B20316	3/16"	X	20"	18"	BULK	25
715B24316	3/16"	X	24"	22"	BULK	25
715B41464	7/32"	X	4-1/2"	2"	BULK	50
715B61464	7/32"	X	6-1/2"	4"	BULK	50
715B81464	7/32"	X	8-1/2"	6"	BULK	50
715B10732	7/32"	X	10-1/2"	8"	BULK	25
715B16732	7/32"	X	16"	14"	BULK	25
715B20732	7/32"	X	20"	18"	BULK	25
715B24732	7/32"	X	24"	22"	BULK	25



BOHR HAMMER - BULK DRILLS

SDS-PLUS Rotary Hammer Drills

Part #	Size	X	OAL	Drilling	Pack	Min.Qty.
715B41664	1/4"	X	4-1/2"	2"	BULK	50
715B61664	1/4"	X	6-1/2"	4"	BULK	100
715B81664	1/4"	X	8-1/2"	6"	BULK	50
715B10014	1/4"	X	10-1/2"	8"	BULK	50
715B14014	1/4"	X	14"	12"	BULK	25
715B16014	1/4"	X	16"	14"	BULK	25
715B20014	1/4"	X	20"	18"	BULK	25
715B24014	1/4"	X	24"	22"	BULK	25
715B62064	5/16"	X	6-1/2"	4"	BULK	50
715B82064	5/16"	X	8-1/2"	6"	BULK	25
715B12516	5/16"	X	12-1/2"	10"	BULK	25
715B62464	3/8"	X	6-1/2"	4"	BULK	100
715B82464	3/8"	X	8-1/2"	6"	BULK	50
715B10038	3/8"	X	10-1/2"	8"	BULK	25
715B12038	3/8"	X	12-1/2"	10"	BULK	25
715B18038	3/8"	X	18"	16"	BULK	25
715B24038	3/8"	X	24"	22"	BULK	25
715B63264	1/2"	X	6-1/2"	4"	BULK	100
715B10012	1/2"	X	10-1/2"	8"	BULK	25
715B12012	1/2"	X	12-1/2"	10"	BULK	25
715B12018	1/2"	X	18"	16"	BULK	25
715B12024	1/2"	X	24"	22"	BULK	25



4-PLUS

A new, fast and tough serrated carbide tip provides long life, easy centering, and fast drilling through all aggregates, concrete, masonry, brick and natural stone.

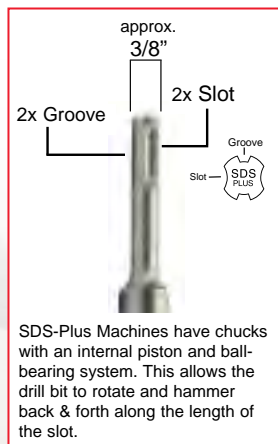

SDS-Plus Machines have chucks with an internal piston and ball-bearing system. This allows the drill bit to rotate and hammer back & forth along the length of the slot.





Reinforced Concrete **Stone**



Brick **Masonry**

- ◆ Rotary Hammer Drill
- ◆ 4 x 90° Serrated Tip Geometry
- ◆ One Pc. Solid Carbide Head up to 3/8"
- ◆ ANSI Specification
- ◆ Drills Reinforced Concrete
- ◆ Rebar Chamfers
- ◆ Centering Tip
- ◆ 50% More Holes
- ◆ Optimized Core Ensures Impact Durability and Rotational Stability
- ◆ High Break Resistance
- ◆ Less Vibration



eVolution™

DRILLS REINFORCED CONCRETE!

SDS-PLUS Rotary Hammer Drills

Part #	Size	X	OAL	Drilling	Head	Qty.
EVL41064	5/32"	X	4-1/2"	2"	REGULAR	1
EVL61064	5/32"	X	6-1/2"	4"	REGULAR	1
EVL41264	3/16"	X	4-1/2"	2"	4X4	1
EVL61264	3/16"	X	6-1/2"	4"	4X4	1
EVL61264-B	3/16"	X	6-1/2"	4"	4X4	25
EVL81264	3/16"	X	8-1/2"	6"	4X4	1
EVL10316	3/16"	X	10-1/2"	8"	4X4	1
EVL12316	3/16"	X	12-1/2"	10"	4X4	1
EVL41664	1/4"	X	4-1/2"	2"	4X4	1
EVL61664	1/4"	X	6-1/2"	4"	4X4	1
EVL61664-B	1/4"	X	6-1/2"	4"	4X4	25
EVL81664	1/4"	X	8-1/2"	6"	4X4	1
EVL10014	1/4"	X	10-1/2"	8"	4X4	1
EVL12014	1/4"	X	12-1/2"	10"	4X4	1
EVL62064	5/16"	X	6-1/2"	4"	4X4	1
EVL62064-B	5/16"	X	6-1/2"	4"	4X4	25
EVL12516	5/16"	X	12-1/2"	10"	4X4	1
EVL18516	5/16"	X	18"	16"	4X4	1
EVL62464	3/8"	X	6-1/4"	4"	4X4	1
EVL62464-B	3/8"	X	6-1/4"	4"	4X4	25
EVL12038	3/8"	X	12-1/4"	10"	4X4	1
EVL18038	3/8"	X	18"	16"	4X4	1
EVL62864	7/16"	X	6-1/4"	4"	4X4	1
EVL12716	7/16"	X	12-1/4"	10"	4X4	1
EVL18716	7/16"	X	18"	16"	4X4	1
EVL63264	1/2"	X	6-1/4"	4"	4X4	1
EVL63264-B	1/2"	X	6-1/4"	4"	4X4	25
EVL12012	1/2"	X	12-1/4"	10"	4X4	1
EVL18012	1/2"	X	18"	16"	4X4	1
EVL63664	9/16"	X	6-1/4"	4"	4X4	1
EVL12916	9/16"	X	12-1/4"	10"	4X4	1
EVL18916	9/16"	X	18"	16"	4X4	1



X-CUTTER *DRILLS REINFORCED CONCRETE!*

SDS-PLUS Rotary Hammer Drills

Part #	Size	X	OAL	Drilling	Head
750TE010	5/8"	X	8-1/4"	6"	X-CUTTER
750TE020	5/8"	X	10-1/4"	8"	X-CUTTER
750TE030	5/8"	X	12-1/4"	10"	X-CUTTER
750TE040	5/8"	X	18"	16"	X-CUTTER
750TE090	3/4"	X	8"	6"	X-CUTTER
750TE100	3/4"	X	10"	8"	X-CUTTER
750TE110	3/4"	X	12"	10"	X-CUTTER
750TE120	3/4"	X	18"	16"	X-CUTTER
750TE140	7/8"	X	8"	6"	X-CUTTER
750TE150	7/8"	X	10"	8"	X-CUTTER
750TE160	7/8"	X	12"	10"	X-CUTTER
750TE170	7/8"	X	18"	16"	X-CUTTER
750TE190	1"	X	10"	8"	X-CUTTER
750TE200	1"	X	12"	10"	X-CUTTER
750TE210	1"	X	18"	16"	X-CUTTER
750TE220	1-1/8"	X	10"	8"	X-CUTTER
750TE230	1-1/8"	X	18"	16"	X-CUTTER
750TE240	1-1/4"	X	18"	16"	X-CUTTER

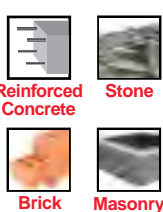

- ◆ Rotary Hammer Drill
- ◆ 4 x 90° Carbide Head
- ◆ Self Centering Chisel Point
- ◆ ANSI Specification
- ◆ Special Tungsten Carbide Tip
- ◆ Copper / Silver Brazing
- ◆ Fast Dust Removal
- ◆ Fast Drilling Speeds
- ◆ Clean Round Holes
- ◆ Less Vibration
- ◆ Polished Finish





Spline Drive Rotary Hammer Drills

Part #	Size	X	OAL	Drilling	Head
717SP1238	3/8"	X	10"	5"	REGULAR
717SP1638	3/8"	X	16"	11"	REGULAR
717SP1212	1/2"	X	10"	5"	REGULAR
717SP1612	1/2"	X	16"	11"	REGULAR
717SP2212	1/2"	X	22"	17"	REGULAR
717SP3612	1/2"	X	36"	31"	REGULAR
717SP1258	5/8"	X	10"	5"	REGULAR
717SP1658	5/8"	X	16"	11"	REGULAR
717SP2258	5/8"	X	22"	17"	REGULAR
717SP1634	3/4"	X	16"	11"	REGULAR
717SP2234	3/4"	X	22"	17"	REGULAR
717SP1678	7/8"	X	16"	11"	REGULAR
717SP2278	7/8"	X	22"	17"	REGULAR
717SP1601	1"	X	16"	11"	REGULAR
717SP2201	1"	X	22"	17"	REGULAR
717SP1618	1-1/8"	X	16"	11"	REGULAR
717SP2218	1-1/8"	X	22"	17"	REGULAR
717SP1614	1-1/4"	X	16"	11"	REGULAR
717SP2214	1-1/4"	X	22"	17"	REGULAR
717SP6112	1-1/2"	X	16"	11"	REGULAR
717SP4112	1-1/2"	X	22"	17"	REGULAR



- ◆ Rotary Hammer Drill
- ◆ Industrial Quality
- ◆ Special Tungsten Carbide Tip
- ◆ Copper / Silver Brazing
- ◆ Fastest Dust Removal
- ◆ Fastest Drilling Speeds
- ◆ Heat Treated Body
- ◆ Clean Round Holes
- ◆ Less Vibration
- ◆ Polished Finish
- ◆ ANSI Specification



SOLD INDIVIDUALLY
1 PER TUBE.

X-CUTTER *DRILLS REINFORCED CONCRETE!*

Spline Drive Rotary Hammer Drills

Part #	Size	X	OAL	Drilling	Head
7SPCR1058	5/8"	X	10"	6"	X-CUTTER
7SPCR1658	5/8"	X	16"	11"	X-CUTTER
7SPCR2258	5/8"	X	22"	17"	X-CUTTER
7SPCR2958	5/8"	X	29"	24"	X-CUTTER
7SPCR3658	5/8"	X	36"	31"	X-CUTTER
7SPCR1034	3/4"	X	10"	6"	X-CUTTER
7SPCR1634	3/4"	X	16"	11"	X-CUTTER
7SPCR2234	3/4"	X	22"	17"	X-CUTTER
7SPCR2934	3/4"	X	29"	24"	X-CUTTER
7SPCR3634	3/4"	X	36"	31"	X-CUTTER
7SPCR1678	7/8"	X	16"	11"	X-CUTTER
7SPCR2278	7/8"	X	22"	17"	X-CUTTER
7SPCR1601	1"	X	16"	11"	X-CUTTER
7SPCR2201	1"	X	22"	17"	X-CUTTER
7SPCR3601	1"	X	36"	31"	X-CUTTER
7SPCR1618	1-1/8"	X	16"	11"	X-CUTTER
7SPCR2218	1-1/8"	X	22"	17"	X-CUTTER
7SPCR1614	1-1/4"	X	16"	11"	X-CUTTER
7SPCR2214	1-1/4"	X	22"	17"	X-CUTTER
7SPCR3614	1-1/4"	X	36"	31"	X-CUTTER
7SPCR2238	1-3/8"	X	22"	17"	X-CUTTER
7SPCR2212	1-1/2"	X	22"	17"	X-CUTTER
7SPCR3423	1-3/4"	X	23"	18"	X-CUTTER

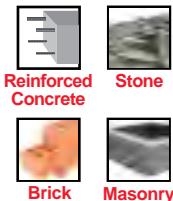

- ◆ Rotary Hammer Drill
- ◆ Industrial Quality
- ◆ 4-Cutter Head
- ◆ Special Tungsten Carbide Tip
- ◆ Copper / Silver Brazing
- ◆ Fastest Dust Removal
- ◆ Fastest Drilling Speeds
- ◆ Heat Treated Body
- ◆ Clean Round Holes
- ◆ Less Vibration
- ◆ Polished Finish
- ◆ ANSI Specification

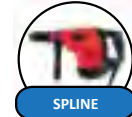

SOLD INDIVIDUALLY
1 PER TUBE.



INTERNATIONAL TOOL MANUFACTURING
 150 Express St. Plainview, NY 11803
 (516) 738-0388 • (800) 247-5696
 Fax (516) 279-1106

X-CUTTER *DRILLS REINFORCED CONCRETE!*

SDS-MAX® Rotary Hammer Drills



Reinforced Concrete

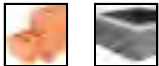

Brick Masonry

- ◆ Rotary Hammer Drill
- ◆ Industrial Quality
- ◆ Special Tungsten Carbide Tip
- ◆ Copper / Silver Brazing
- ◆ Fastest Dust Removal
- ◆ Fastest Drilling Speeds
- ◆ Heat Treated Body
- ◆ Clean Round Holes
- ◆ Less Vibration
- ◆ Polished Finish
- ◆ ANSI Specification



SOLD INDIVIDUALLY
1 PER TUBE.



Bosch® License



Part #	Size	X	OAL	Drilling	Head
SMTE1338	3/8"	X	13"	8"	REGULAR
SMTE1312	1/2"	X	13"	8"	REGULAR
SMTE1712	1/2"	X	17"	12"	REGULAR
SMTE2212	1/2"	X	21"	16"	REGULAR
SMTE1391	9/16"	X	13"	8"	REGULAR
SMTE2192	9/16"	X	21"	16"	REGULAR
SMTE1358	5/8"	X	13"	8"	X-CUTTER
SMTE1758	5/8"	X	17"	12"	X-CUTTER
SMTE2258	5/8"	X	21"	16"	X-CUTTER
SMTE3658	5/8"	X	36"	31"	X-CUTTER
SMTE2111	11/16"	X	21"	16"	X-CUTTER
SMTE1334	3/4"	X	13"	8"	X-CUTTER
SMTE1734	3/4"	X	17"	12"	X-CUTTER
SMTE2234	3/4"	X	21"	16"	X-CUTTER
SMTE3634	3/4"	X	36"	31"	X-CUTTER
SMTE2113	13/16"	X	21"	16"	X-CUTTER
SMTE1378	7/8"	X	13"	8"	X-CUTTER
SMTE1778	7/8"	X	17"	12"	X-CUTTER
SMTE2278	7/8"	X	21"	16"	X-CUTTER
SMTE3678	7/8"	X	36"	31"	X-CUTTER
SMTE1301	1"	X	13"	8"	X-CUTTER
SMTE1701	1"	X	17"	12"	X-CUTTER
SMTE2201	1"	X	21"	16"	X-CUTTER
SMTE3601	1"	X	36"	31"	X-CUTTER
SMTE2311	1-1/16"	X	23"	18"	X-CUTTER
SMTE1718	1-1/8"	X	17"	12"	X-CUTTER
SMTE2218	1-1/8"	X	21"	16"	X-CUTTER
SMTE3618	1-1/8"	X	36"	31"	X-CUTTER
SMTE1714	1-1/4"	X	15"	10"	X-CUTTER
SMTE2214	1-1/4"	X	23"	18"	X-CUTTER
SMTE3614	1-1/4"	X	36"	31"	X-CUTTER
SMTE1738	1-3/8"	X	17"	12"	X-CUTTER
SMTE2238	1-3/8"	X	23"	18"	X-CUTTER
SMTE3638	1-3/8"	X	36"	31"	X-CUTTER
SMTE1721	1-1/2"	X	17"	12"	X-CUTTER
SMTE2221	1-1/2"	X	23"	18"	X-CUTTER
SMTE3621	1-1/2"	X	36"	31"	X-CUTTER
SMTE2334	1-3/4"	X	23"	18"	X-CUTTER
SMTE3613	1-3/4"	X	36"	31"	X-CUTTER
SMTE2202	2"	X	23"	18"	X-CUTTER



SDS-MAX® Rotary Hammer - Extra Long

Part #	Size	X	OAL	Drilling	Head	Qty.
SMTE5258	5/8"	X	52"	47"	CROSS HEAD	1
SMTE5234	3/4"	X	52"	47"	CROSS HEAD	1
SMTE5201	1"	X	52"	47"	CROSS HEAD	1
SMTE5214	1-1/4"	X	52"	47"	CROSS HEAD	1
SMTE5212	1-1/2"	X	52"	47"	CROSS HEAD	1

X-Tend Your Drilling Depths!



X-Tendr™ - MAX to MAX SHANK ADAPTER

Part #	Description
XT6700	Adapter (1-3/16" x 7-1/2")
XT6750	Adapter Grease (Tube)

Drill Bit Diameter Must Be 1-1/4" Or Larger if X-Tendr™ is to Pass Through Hole Being Drilled.

Drill bit extension system for all SDS-MAX & Spline machines.

- ◆ X-Tend Any SDS-MAX Tool
- ◆ Quick & Safe Connection
- ◆ Simple To Use
- ◆ No Energy Loss
- ◆ No Weak Points
- ◆ Saves Time & Money
- ◆ Reduces Tool Requirements
- ◆ Sold Individually

How it works:

- X-Tendr™ Adapter has double locking SDS-MAX inputs.
- All EXTENSION SHAFTS have 1 SDS-MAX end which locks into X-Tendr™ Adapter. Other end can be inserted into either an SDS-MAX or Spline machine.
- X-Tend any SDS-MAX drill bit, core bit, tunnel bore drill, drill head, or chisel.
- Reach of X-Tendr™ system limited to 1 adapter and 1 extension.



X-Tendr™ Extension Shafts

Part #	OAL	Shank
XT6701	12-1/2"	SDS-MAX
XT6702	30"	SDS-MAX
XT6703	44"	SDS-MAX
XT6704	82-1/2"	SDS-MAX
XT6708	12-1/2"	SPLINE
XT6709	30"	SPLINE



1. Choose either SDS-MAX® or SPLINE Drive and desired length Extension.



2. Attach X-Tendr™ Adaptor to SDS-MAX® end of Extension.



3. Attach desired SDS-MAX® Rotary Hammer Drill Bit, Core Bit, Tunnel Bore Drill or Chisel.

Drill Bit Diameter Must Be 1-1/4" Or Larger if X-Tendr™ is to Pass Through Hole Being Drilled.

X-TEND YOUR OPTIONS...





INTERNATIONAL TOOL MANUFACTURING

150 Express St. Plainview, NY 11803

(516) 738-0388 • (800) 247-5696

Fax (516) 279-1106



Concrete



Stone



Brick



Masonry

- ◆ Industrial Quality
- ◆ 1 Piece Construction
- ◆ Special Tungsten Carbide Tip
- ◆ Copper / Silver Brazing
- ◆ Fast Drilling Speed
- ◆ Clean Round Holes
- ◆ Less Vibration
- ◆ Polished Finish



SOLD INDIVIDUALLY
1 PER TUBE.



SDS-MAX® Tunnel Bore Drills

Part #	Size	X	OAL	Shank
950CC7331	1-1/2"	X	22"	SDS-MAX
950CC7333	1-3/4"	X	22"	SDS-MAX
950CC7342	1-3/4"	X	39"	SDS-MAX
950CC7337	2-1/8"	X	22"	SDS-MAX
950CC7343	2-1/8"	X	39"	SDS-MAX
950CC7339	2-1/2"	X	22"	SDS-MAX
950CC7344	2-1/2"	X	39"	SDS-MAX
950CC7341	3-1/8"	X	22"	SDS-MAX
950CC7345	3-1/8"	X	39"	SDS-MAX



Extensions on Page 101.

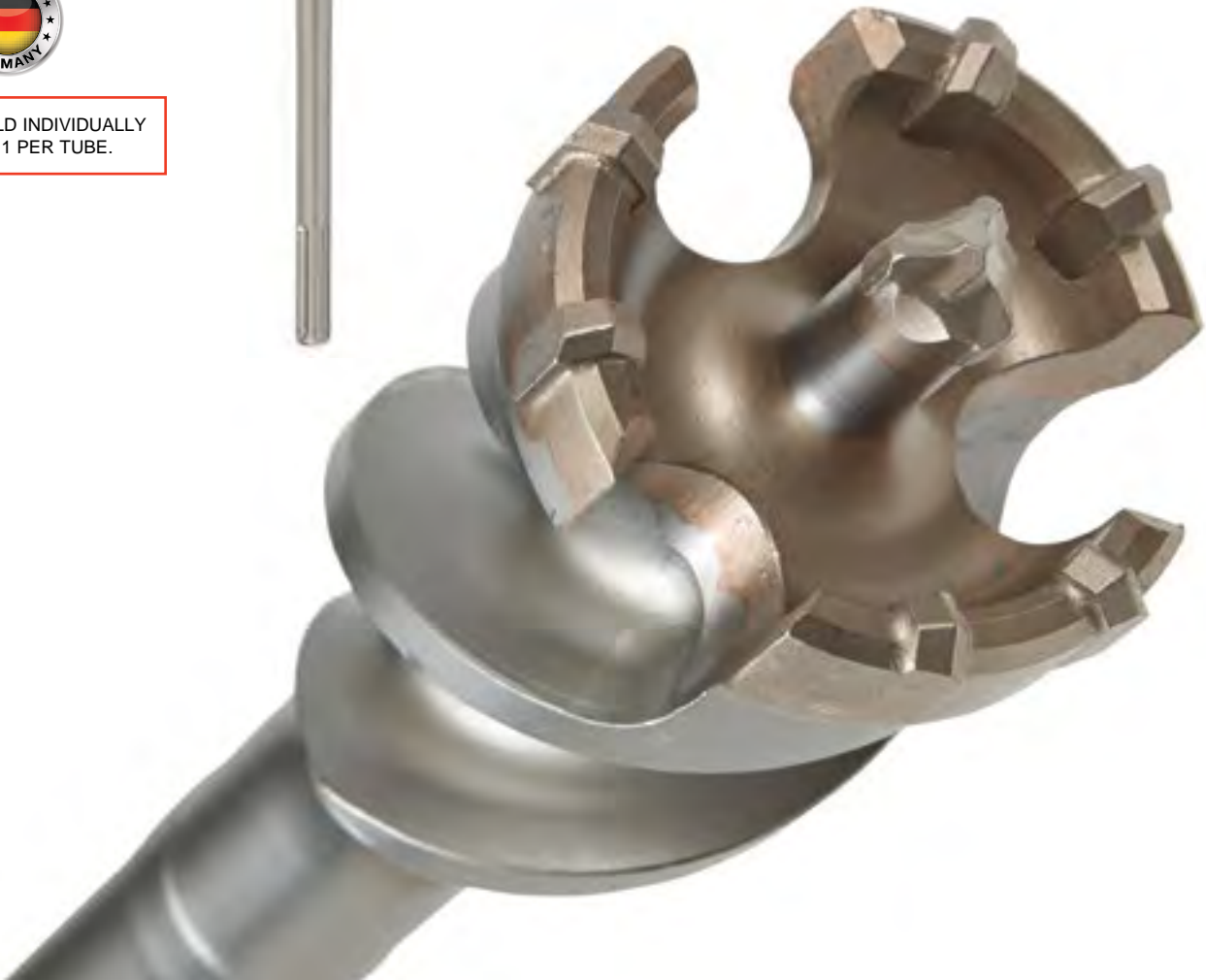

Adapters

Part #	Description	OAL
800RA010	SPLINE ADAPTER	7"
800RA020	SDS-MAX ADAPTER	7"

Pilot Drills

Part #	Description
800RP124	5/8" X 4-3/4" PILOT
800RP174	5/8" X 6-3/4" PILOT
800RP255	1/2" X 6" PILOT

Cruciform™ Drill Heads

Part #	Description	OAL
800RC040	1-1/2" DRILL HEAD	1-1/2"
800RC045	1-3/4" DRILL HEAD	1-1/2"
800RC052	2" DRILL HEAD	1-1/2"
800RC065	2-5/8" DRILL HEAD	1-1/2"
800RC080	3-1/8" DRILL HEAD	1-1/2"
800RC090	3-1/2" DRILL HEAD	1-1/2"
800RC100	4" DRILL HEAD	1-1/2"
800RC110	4-1/2" DRILL HEAD	1-1/2"
800RC125	5" DRILL HEAD	1-1/2"
800RC150	6" DRILL HEAD	1-1/2"

Extensions

Part #	Description
800RE300	11" LONG EXTENSION
800RE350	12" LONG EVACUATION EXTENSION
800RE450	18" LONG EXTENSION

Hard Body Spiral Flutes

Part #	Description	OAL
800RF145	1-1/2" FLUTE	4"] Same flute fits 1-1/2" & 1-3/4"
800RF145	1-3/4" FLUTE	4"]
800RF152	2" FLUTE	4"]
800RF165	2-5/8" FLUTE	4"]
800RF180	3-1/8" FLUTE	4"] Same flute fits 3-1/8" & 3-1/2"
800RF180	3-1/2" FLUTE	4"]

Ratio Core Bits - INTERNAL THREAD

Part #	Description	OAL
800RK150	1-1/2" CORE BIT	3"
800RK150	1-3/4" CORE BIT	3"
800RK200	2" CORE BIT	3"
800RK250	2-5/8" CORE BIT	3"
800RK300	3-1/8" CORE BIT	3"
800RK350	3-1/2" CORE BIT	3"
800RK400	4" CORE BIT	3"
800RK450	4-1/2" CORE BIT	3"
800RK500	5" CORE BIT	3"
800RK600	6" CORE BIT	3"



◆ 5/8" - 11 Internal Thread



- RECOMMENDED.
- BETTER FOR DEEP DRILLING.
- FOR RATIO CORE BIT ONLY!!!



Replacement Coupler
5/8" - 11 X 2" OAL
800RT001



- ◆ Modular System
- ◆ Up to 6" Diameter
- ◆ Allows for Angle Drilling
- ◆ Use With or Without Spiral Flute
- ◆ Adapters Accommodate Any Combination
- ◆ Unmatched Flexibility
- ◆ Sold Individually

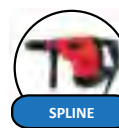

USE PILOT DRILL # 800RP255 ONLY!!!

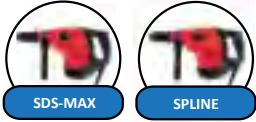

Pilot Drill - A-TAPER FOR EXTENSION

Part #	Size
721PD0385	3/8" X 6" A-TAPER

Ejector Key

Part #	Description
722EJ001	EJECTOR KEY



Carbide Core Bit - 4" OAL / TAPER

Part #	Size	# Teeth
719CB0040	1-1/2"	6
719CB0050	2"	6
719CB0065	2-1/2"	9
719CB0080	3" (3-1/8")	9
719CB0090	3-1/2" (3-9/16")	9
719CB0100	4"	9
719CB0125	5"	12

All 3-1/2" Diameter Core Bits Are Now 3-9/16"

These Heavy Duty Rotary Hammer Core Bits are used with either Spline or SDS-MAX electric rotary hammer machines. The special alloy steel body and Tungsten Carbide withstand continuous hammering. A pilot drill bit and extension are required.



TAPER

INSTRUCTIONS

- 1 Wipe off oil or lubricant from the taper of the extension and the inner taper of the core bit.
- 2 Insert the pilot drill into the drive extension first.
- 3 Insert the drive extension into the core bit.
- 4 Start drilling hole until the core bit is 3/8" deep.
- 5 Use the ejector key to push out the pilot drill.
- 6 Continue drilling the hole until the material being drilled fills the core bit interior. Approximately 3" deep.
- 7 Break the drilled material inside the core bit with a chisel (if necessary.)
- 8 Return to Step 6 until desired hole depth is achieved.

SOLD INDIVIDUALLY
1 PER TUBE.

Taper Shank Extensions

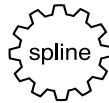

SPLINE DRIVE

Part #	Size	Shank
720SP0008	8"	SPLINE
720SP0018	18"	SPLINE



SDS - MAX®

Part #	Size	Shank
720MAX008	8"	SDS-MAX
720MAX018	18"	SDS-MAX



Notice: Core Bit drilling without the use of a pilot drill bit causes excessive pressure on the taper shank system. This can result in breakage to the extension at the tapered end, especially between the two slots. Such jagged breaks are not considered defective and may not be covered under warranty.

1-Pc SDS-MAX® Core Bits

Part #	Size	X	OAL	# Teeth	Shank
990HH1015	1-1/2"	X	12"	4	SDS-MAX
990HH1025	1-1/2"	X	22"	4	SDS-MAX
990HH1155	1-3/4"	X	12"	6	SDS-MAX
990HH1165	1-3/4"	X	22"	6	SDS-MAX
990HH1035	2"	X	12"	6	SDS-MAX
990HH1045	2"	X	22"	6	SDS-MAX
990HH1055	2-5/8"	X	12"	8	SDS-MAX
990HH1065	2-5/8"	X	22"	8	SDS-MAX
990HH1075	3-1/8"	X	12"	8	SDS-MAX
990HH1085	3-1/8"	X	22"	8	SDS-MAX
990HH1095	3-9/16"	X	12"	10	SDS-MAX
990HH1105	3-9/16"	X	22"	10	SDS-MAX
990HH1115	4"	X	12"	10	SDS-MAX
990HH1125	4"	X	22"	10	SDS-MAX
990HH1215	5"	X	12"	14	SDS-MAX
990HH1135	5"	X	22"	14	SDS-MAX
990HH1145	6"	X	22"	18	SDS-MAX

All 3-1/2" Diameter Core Bits Are Now 3-9/16"

1-Pc Spline Core Bits

Part #	Size	X	OAL	# Teeth	Shank
920HH1505	1-1/2"	X	12"	4	SPLINE
920HH1515	1-1/2"	X	22"	4	SPLINE
920HH1525	2"	X	12"	6	SPLINE
920HH1535	2"	X	22"	6	SPLINE
920HH1545	2-5/8"	X	12"	8	SPLINE
920HH1555	2-5/8"	X	22"	8	SPLINE
920HH1565	3-1/8"	X	12"	8	SPLINE
920HH1575	3-1/8"	X	22"	8	SPLINE
920HH1585	3-9/16"	X	12"	10	SPLINE
920HH1595	3-9/16"	X	22"	10	SPLINE
920HH1615	4"	X	22"	10	SPLINE
920HH1635	5"	X	22"	14	SPLINE
920HH1655	6"	X	22"	18	SPLINE

All 3-1/2" Diameter Core Bits Are Now 3-9/16"



- ◆ Industrial Quality
- ◆ 1 Piece Construction
- ◆ Special Tungsten Carbide Tip
- ◆ Copper / Silver Brazing
- ◆ Clean Round Holes
- ◆ Less Vibration
- ◆ Polished Finish
- ◆ 3" Cutting Depth Before Core Removal



SOLD INDIVIDUALLY
1 PER TUBE.



Each Core Bit Includes Pilot Drill & Key

Pilot Drill & Key - REPLACEMENT PARTS

Part #	Size
900PD1143	7/16" X 4-3/4" PILOT DRILL
900DK7006	3/8" ROUND DRIFT KEY

Asymmetrical Tooth Arrangement For Faster Drilling Process





Rotation Only!



Reinforced Concrete



Stone



Masonry



Brick



Granite



Marble

- ◆ CLIC System
- ◆ Diamond Teeth
- ◆ Capable of Dry Drilling in Reinforced Concrete
- ◆ Carbide Tipped Center Pin
- ◆ Clean Round Holes
- ◆ Made in Japan
- ◆ Each Piece Sold Individually



JAPAN



Replacement Guide Plates Available.



Superdry™ Center Pin

Part #	Description
DRY-CP1	CENTER PIN - FOR SUPERDRY DIAMOND



WON'T BLOW THE BACK OUT

Superdry™ Diamond Core Bit

Part #	Size	# Teeth	Drilling	Shank
DRY-25C	1"	6	6"	#1
DRY-29C	1-1/8"	7	6"	#1
DRY-32C	1-1/4"	8	6"	#1
DRY-35C	1-3/8"	8	6"	#1
DRY-38C	1-1/2"	9	6"	#1
DRY-45C	1-3/4"	9	6"	#1
DRY-50C	2"	10	6"	#2
DRY-55C	2-1/8"	11	6"	#2
DRY-60C	2-3/8"	12	6"	#2
DRY-65C	2-9/16"	12	6"	#2
DRY-70C	2-3/4"	13	6"	#2
DRY-75C	2-7/8"	15	6"	#2
DRY-80C	3-1/8"	16	6"	#2
DRY-90C	3-1/2"	16	6"	#2
DRY-95C	3-3/4"	16	6"	#2
DRY-100C	3-7/8"	17	6"	#2
DRY-105C	4-1/8"	17	6"	#2
DRY-120C	4-3/4"	17	6"	#2
DRY-130C	5-1/8"	18	6"	#2
DRY-155C	6"	22	6"	#2
DRY-165C	6-1/2"	24	6"	#2
DRY-180C	7"	25	6"	#2
DRY-210C	8-1/4"	30	6"	#2



Superdry™ SDS-Plus Extension

Part #	Size	Shank
DRY-S1-8	5" EXTENSION (FOR 1" THRU 1-3/4")	#1
DRY-S1-12	8" EXTENSION (FOR 1" THRU 1-3/4")	#1
DRY-S2-8	5" EXTENSION (FOR 2" THRU 8-1/4")	#2
DRY-S2-12	8" EXTENSION (FOR 2" THRU 8-1/4")	#2





Each Extension Comes With One Pilot Bit



SDS-PLUS Extension and Pilot Bit

Part #	Size
LCB-PILOT	Carbide Pilot Bit (5/16" x 4-3/4")
LCB-12EX	12" SDS-Plus Extension with Pilot Bit
LCB-18EX	18" SDS-Plus Extension with Pilot Bit



Concrete Stone



Brick Masonry

- ◆ Industrial Quality
- ◆ Tungsten Carbide Teeth
- ◆ M16 Thread
- ◆ 2" Cutting Depth
- ◆ Use Rotary Hammer Action
- ◆ Clean Round Holes
- ◆ Each Piece Sold Individually



Carbide Lightweight Core Bits

Part #	Size	Depth	Teeth	Shank
LCB-1	1-3/16"	2"	6	SDS-PLUS
LCB-2	1-3/8"	2"	6	SDS-PLUS
LCB-3	1-9/16"	2"	6	SDS-PLUS
LCB-4	1-3/4"	2"	6	SDS-PLUS
LCB-5	2"	2"	6	SDS-PLUS
LCB-6	2-9/16"	2"	6	SDS-PLUS
LCB-7	3-1/8"	2"	6	SDS-PLUS
LCB-8	3-1/2"	2"	6	SDS-PLUS
LCB-9	4"	2"	8	SDS-PLUS



Exhaust Slots For Easy Core Removal.

Carbide Serrations For Quick Drilling And Precise Holes.





Diamond Core Bits - Stone Countertops

Part #	Size	X	OAL	# Teeth	Thread
GRA-09	1"	X	4"	3	5/8" x 11
GRA-10	1-1/4"	X	4"	3	5/8" x 11
GRA-11	1-3/8"	X	4"	4	5/8" x 11
GRA-12	1-1/2"	X	4"	4	5/8" x 11
GRA-13	2"	X	4"	4	5/8" x 11
GRA-15	3"	X	4"	5	5/8" x 11
GRA-18	4"	X	4"	6	5/8" x 11



- ◆ Stone Countertops
- ◆ Quality Premium Diamond Teeth
- ◆ 2-1/2" Cutting Depth
- ◆ Vacuum Brazed Side Diamond
- ◆ 10mm Segments
- ◆ Sold Individually



SDS-Plus to 5/8"-11 Adapter
P. 109



Diamond Core Bits - Dry Drilling

Part #	Size	X	OAL	# Teeth	Thread
DRX-02	1-1/4"	X	10-3/4"	3	5/8" x 11
DRX-03	1-1/2"	X	10-3/4"	3	5/8" x 11
DRX-04	2"	X	10-3/4"	4	5/8" x 11
DRX-05	2-1/2"	X	10-3/4"	4	5/8" x 11
DRX-07	3"	X	10-3/4"	4	5/8" x 11



- ◆ Industrial Quality
- ◆ Quality Premium Diamond Teeth
- ◆ 9" Cutting Depth
- ◆ Dry Drilling
- ◆ 10mm Segments
- ◆ Sold Individually



FOR USE WITH
A 7" ANGLE
GRINDER



FOR DRILLING
LARGER DIAMETER
HOLES IN CONCRETE



Diamond Core Bits - Premium

Part #	Size	X	OAL	# Teeth	Thread
KDX-01	1"	X	15-3/4"	3	5/8"-11
KDX-02	1-1/4"	X	15-3/4"	4	5/8"-11
KDX-25	1-1/2"	X	15-3/4"	4	5/8"-11
KDX-03	1-3/4"	X	15-3/4"	4	1-1/4" x 7
KDX-04	2"	X	15-3/4"	5	1-1/4" x 7
KDX-05	2-1/2"	X	15-3/4"	6	1-1/4" x 7
KDX-06	2-3/4"	X	15-3/4"	6	1-1/4" x 7
KDX-07	3"	X	15-3/4"	6	1-1/4" x 7
KDX-75	3-1/2"	X	15-3/4"	6	1-1/4" x 7
KDX-08	4"	X	15-3/4"	8	1-1/4" x 7
KDX-95	4-1/2"	X	15-3/4"	9	1-1/4" x 7
KDX-11	5"	X	15-3/4"	10	1-1/4" x 7
KDX-12	6"	X	15-3/4"	12	1-1/4" x 7
KDX-65	6-1/2"	X	15-3/4"	12	1-1/4" x 7
KDX-20	8"	X	15-3/4"	16	1-1/4" x 7
KDX-30	10"	X	15-3/4"	18	1-1/4" x 7
KDX-40	12"	X	15-3/4"	20	1-1/4" x 7

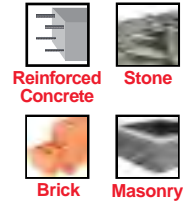

- ◆ Industrial Quality
- ◆ Quality Premium Diamond Teeth
- ◆ 14" Cutting Depth
- ◆ Use With Water



SOLD INDIVIDUALLY
1 PER BOX.

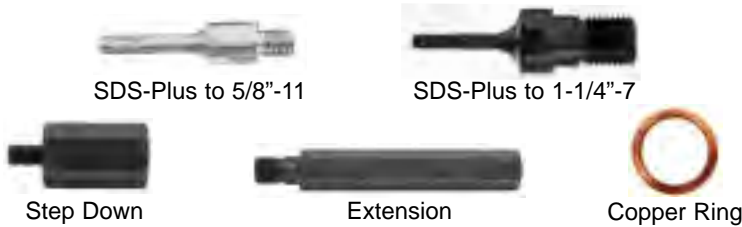

Diamond Core Adapters / Extensions

Part #	Description
ADA001	ADAPTER STEP DOWN (1-1/4"-7 TO 5/8"-11)
ADA002	SDS-PLUS TO 5/8"-11 ADAPTER
ADA003	SDS-PLUS TO 1-1/4"-7 ADAPTER
DCEXT01	6" DIAMOND CORE BIT EXTENSION (5/8"-11)
DCEXT02	12" DIAMOND CORE BIT EXTENSION (5/8"-11)
DCEXT03	6" DIAMOND CORE BIT EXTENSION (1-1/4"-7)
DCEXT04	12" DIAMOND CORE BIT EXTENSION (1-1/4"-7)
CR01	COPPER RING (FOR EASY CORE BIT REMOVAL)



Diamond Core Machine Adapters

Part #	Description
HILA001	HILTI BI+ TO 5/8"-11 ADAPTER
HILA002	HILTI BI+ TO 1-1/4"-7 ADAPTER
HILA003	HILTI BL TO 1-1/4"-7 ADAPTER
HILA004	HILTI SPLINE TO 1-1/4"-7 ADAPTER

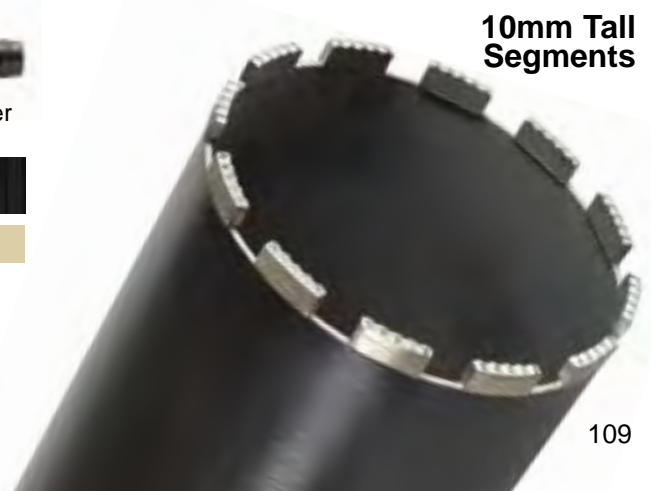



Concrete Stone



Brick Masonry

- ◆ Rotary Hammer Drill
- ◆ Industrial Quality
- ◆ 4-Cutter Head
- ◆ Two Large Suction Holes
- ◆ Cleaner and Faster
- ◆ Copper / Silver Brazing
- ◆ Heat Treated Body
- ◆ Clean Round Holes
- ◆ Less Vibration
- ◆ Polished Finish
- ◆ ANSI Specification

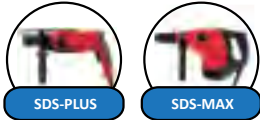

SOLD INDIVIDUALLY.



SDS-Plus Duster Drill Bit

Part #	Size	X	OAL	Drilling	Head
EXS-038	3/8"	X	10-1/2"	6"	DUSTER
EXS-716	7/16"	X	13"	8"	DUSTER
EXS-012	1/2"	X	13"	8"	DUSTER
EXS-916	9/16"	X	14"	9"	DUSTER
EXS-058	5/8"	X	14"	9"	DUSTER
EXS-034	3/4"	X	14"	9"	DUSTER
EXS-078	7/8"	X	14"	9"	DUSTER

EXS-1S PLASTIC ADAPTER SDS-PLUS REPLACEMENT



SDS-MAX® Duster Drill Bit

Part #	Size	X	OAL	Drilling	Head
EXM-120	1/2"	X	24"	15-1/2"	DUSTER
EXM-580	5/8"	X	24"	15-1/2"	DUSTER
EXM-340	3/4"	X	24"	15-1/2"	DUSTER
EXM-780	7/8"	X	24"	15-1/2"	DUSTER
EXM-100	1"	X	25"	17-1/2"	DUSTER
EXM-118	1-1/8"	X	35"	28"	DUSTER
EXM-138	1-3/8"	X	35"	28"	DUSTER

EXM-1M PLASTIC ADAPTER SDS-MAX REPLACEMENT

Suction Holes



Attach to Any HEPA Rated Vacuum to Meet OSHA Silica Dust Containment Standards.

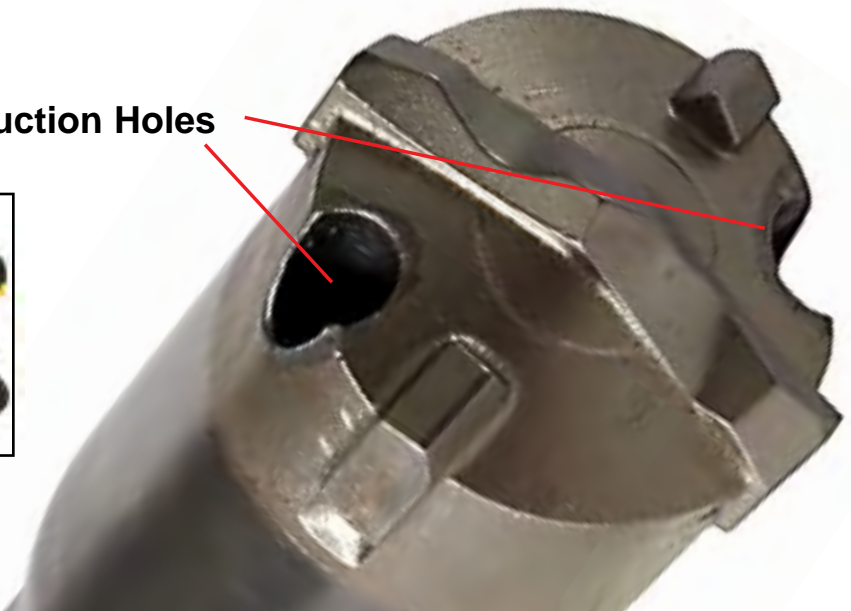



Economy Dust Pro (Up to 1")

Part #	Description	Qty.
DP-1	ECONOMY DUST PRO (PLASTIC)	1



- ◆ Attach to HEPA Vacuum and Stick to Drilling Surface
- ◆ No Drilling Dust
- ◆ No Need to Clean Holes Before Anchoring



JAPAN

SOLD INDIVIDUALLY.



Sold With One Metal Insert.



Small Dust Pro (Up to 1")

Part #	Description	Qty.
DP-2	SMALL DUST PRO	1



Sold With One Rubber Insert.



Large Dust Pro (Up to 3")

Part #	Description	Qty.
DP-3	LARGE DUST PRO	1



Metal Plate for DP-2



Rubber Plate for DP-3



Replacement Inserts

Part #	Description	Qty.
DP-2-PL	METAL PLATE REPLACEMENT	1
DP-3-PL	RUBBER CUT OUT REPLACEMENT	1

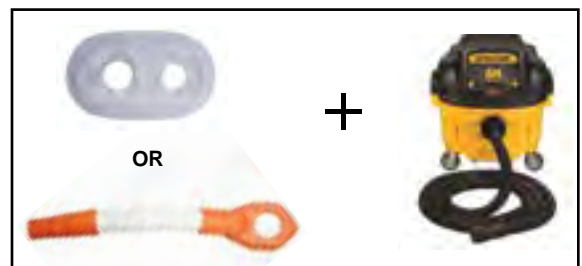

Attach to Any HEPA Rated Vacuum to Meet OSHA Silica Dust Containment Standards.



For Drop-in Anchors



Concrete



Stone



Brick



Masonry



- ◆ Rotary Hammer Drill
- ◆ STOP - Lip Prevents Over-Drilling
- ◆ Drill Exact Depth For Drop-In Anchor
- ◆ Less Likely to Hit Rebar
- ◆ ANSI Specification
- ◆ Sold Individually



SDS-PLUS + STOP Rotary Hammer Bit

Part #	Size	Drill Depth	Anchor Size	Qty.
STP-413	1/4"	11/16"	3/16"	1
STP-617	3/8"	1-1/16"	1/4"	1
STP-813	1/2"	13/16"	3/8" Short	1
STP-827	1/2"	1-11/16"	3/8"	1
STP-1019	5/8"	1-3/16"	1/2" Short	1
STP-1033	5/8"	2-1/16"	1/2"	1
STP-418	7/8"	2-5/8"	5/8"	1
STP-419	1"	3-1/4"	3/4"	1

Use Your SDS-Plus Drill Bits In Larger SDS-MAX® Or Spline Drive Machines:

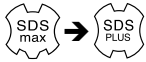

Adapter

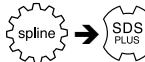

Adapter

SDS-MAX® to SDS-PLUS

Part #	Description
725MAX001	SDS-MAX To SDS-Plus Adapter



Spline to SDS-PLUS

Part #	Description
725SP0001	Spline To SDS-Plus Adapter



Replacement Kit - FOR ADAPTERS

Part #	Description
715KIT001	Gaskets & Ball Bearings



SDS-Max to SDS-Plus Adapter

Half Flat Shank



Concrete Bits - FOR CONCRETE SCREWS

Part #	Size	x	OAL	Screw	Qty.
602TC0503	5/32"	X	3-1/2"	3/16"	50
602TC0500	5/32"	X	4-1/2"	3/16"	50
602TC0505	5/32"	X	5-1/2"	3/16"	50
602TC0603	3/16"	X	3-1/2"	1/4"	50
602TC0604	3/16"	X	4-1/2"	1/4"	50
602TC0605	3/16"	X	5-1/2"	1/4"	50
602TC0606	3/16"	X	6-3/4"	1/4"	50
602TC0607	3/16"	X	7-5/8"	1/4"	50



Concrete Brick Cinderblock

- ◆ Industrial Quality
- ◆ Tungsten Carbide Tip
- ◆ ANSI Specification
- ◆ Sold Individually



Concrete Screw System



Each concrete screw carbide drill bit is precisely ground to match a certain tolerance to assure proper hole diameter and to achieve maximum thread holding power. The flat on the shank fits all drill adapters. The drill bit is specially heat treated to make it very durable.



5/16" HEX SHOULDER

SDS-HEX Bits - FOR CONCRETE SCREWS

Part #	Size	x	OAL	Drilling	Screw	Qty.
HEX5325	5/32"	X	5"	2-1/2"	3/16"	1
HEX5327	5/32"	X	7"	4-1/2"	3/16"	1
HEX3165	3/16"	X	5"	2-1/2"	1/4"	1
HEX3167	3/16"	X	7"	4-1/2"	1/4"	1
HEX2345	.234"	X	5"	2-1/2"	Crete-Flex®	1
HEX2347	.234"	X	7"	4-1/2"	Crete-Flex®	1



Concrete Stone Brick Masonry

- ◆ Industrial Quality
- ◆ Special Tungsten Carbide Tip
- ◆ ANSI Specification
- ◆ Copper / Silver Brazing
- ◆ Polished Finish
- ◆ Sold Individually



Concrete Screw System



SDS-HEX Rotary Hammer drill bits are specifically designed to be used in concrete screw installation. These SDS bits have a special 5/16" HEX shoulder for use with standard concrete screw installation sleeves, which eliminate the need for drill adapters. The benefits of using an SDS machine rather than a standard rotation drill means a decrease in operation time of nearly 50%. **SEE BELOW FOR INSTALLATION KIT**



Concrete Screw Installation Sleeve

Part #	Description	Qty.
TPCDSL	6-1/2" Concrete Screw Sleeve	1



Concrete Screw System

These Installation Kits are Suitable for both Standard Concrete Bits & SDS-HEX Rotary Hammer Bits.

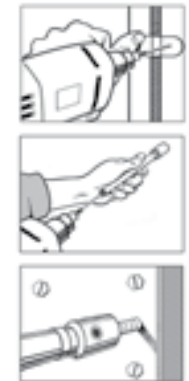

Deluxe Installation Kit

Part #	Description
602TC1000	Installation Kit

INCLUDES:

- 5/32" x 7" SDS-PLUS Hex Bit
- 3/16" x 7" SDS-PLUS Hex Bit
- 1/4" Magnetic Driver
- 5/16" Magnetic Driver
- Phillips Bit Adapter
- Masonry Drill Adapter
- 6-1/2" Sleeve
- 1/8" Hex Key
- Phillips #2 x 1" Insert
- Phillips #3 x 1" Insert

Basic Installation Kit

Part #	Description
602TC2000	Installation Kit

INCLUDES:

- 1/4" Magnetic Driver
- 5/16" Magnetic Driver
- Phillips Bit Adapter
- Masonry Drill Adapter
- 6-1/2" Sleeve
- 1/8" Hex Key
- Phillips #2 x 1" Insert
- Phillips #3 x 1" Insert



Rebar

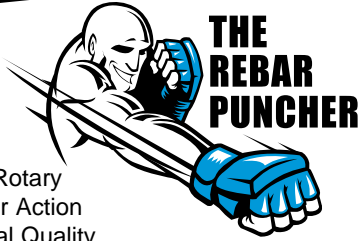

THE REBAR PUNCHER

- ◆ Use in Rotary Hammer Action
- ◆ Industrial Quality
- ◆ Tungsten Carbide Teeth
- ◆ Twice the Speed
- ◆ Ratio System
- ◆ Sold Individually



2X SPEED

NEW!

BEST ON #5 (5/8")
 REBAR SIZE
 AND UNDER.



Rebar Puncher - ROTARY HAMMER ACTION

Part #	Size	OAL	RPM
RG-8	1/2"	9"	HAMMER ACTION
RG-9	9/16"	9"	HAMMER ACTION
RG-10	5/8"	9"	HAMMER ACTION
RG-11	11/16"	9"	HAMMER ACTION
RG-12	3/4"	9"	HAMMER ACTION
RG-14	7/8"	9"	HAMMER ACTION
RG-16	1"	9"	HAMMER ACTION
RG-18	1-1/8"	9"	HAMMER ACTION
RG-20	1-1/4"	9"	HAMMER ACTION



REBAR PUNCHER NOT SOLD WITH SHANK.



Rebar Puncher Shanks

Part #	Description	OAL
RG-PLUS	SDS-PLUS	4"
RG-MAX	SDS-MAX	7-1/4"



Rebar

NEW!

- ◆ Micro SDS-Plus System
- ◆ Tungsten Carbide Teeth
- ◆ Fast Cutting
- ◆ Made in France
- ◆ Sold Individually



Rotation Only!



Rotation Only!



Rebar Cutter - ONE PIECE SYSTEM

Part #	Size	OAL	SHANK
MCX-1	3/8"	8"	SDS-PLUS
MCX-2	1/2"	12"	SDS-PLUS
MCX-3	9/16"	12"	SDS-PLUS
MCX-4	5/8"	12"	SDS-PLUS
MCX-1F	3/8"	8"	3-FLAT
MCX-2F	1/2"	12"	3-FLAT
MCX-3F	9/16"	12"	3-FLAT
MCX-4F	5/8"	12"	3-FLAT



Rebar Cutter - TWO PIECE SYSTEM

MCX-5	3/4"	4"	HEAD ONLY
MCX-6	7/8"	4"	HEAD ONLY
MCX-7	1"	4"	HEAD ONLY
MCX-8	1-1/8"	4"	HEAD ONLY
MCX-9	1-1/4"	4"	HEAD ONLY
MCX-10	1-3/8"	4"	HEAD ONLY
MCX-11	1-1/2"	4"	HEAD ONLY
MCX-SDS	EXTENSION	9"	SDS-PLUS
MCX-FLAT	EXTENSION	9"	3-FLAT

1/2"-13
 Thread

MCX-5 → MCX-11 ARE HEAD ONLY AND YOU WILL NEED TO BUY AN SDS-PLUS OR 3-FLAT THREADED ADAPTER.

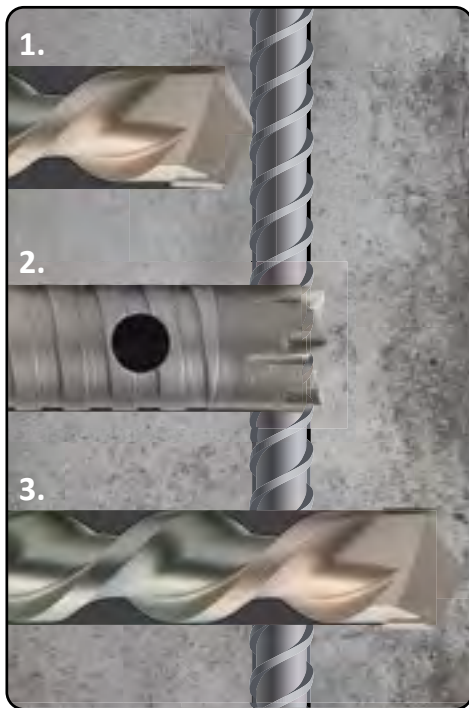

3 SIMPLE STEPS TO DRILLING REBAR

1. When rebar is encountered while drilling, immediately stop the hammer drill and remove the bit from the hole. (failure to do this will severely damage a carbide hammer bit.)
2. With a rotary rebar cutter mounted in a drill motor with the selector in the **rotary only position**, insert the rotary rebar cutter into the hole and drill through the embedded rebar.
3. Remove the rotary rebar cutter after the rebar has been drilled completely through and finish drilling the hole with the hammer bit.

HEAD SIZES	THREAD
3/8" → 1-1/2"	1 pc.
1-3/4" → 2-1/2"	3/4"-10

REMINDER:

Rebar Cutters are problem solvers only. A 1/2" Rebar Cutter drilling through #6 (3/4") rebar dead center may result in 5 to 10 holes being drilled provided correct speed and pressure are utilized. It is not uncommon for only one piece of rebar to be cut per Rebar Cutter. Rebar Cutters *should* not be used for drilling concrete.

Rebar Cutters are not warranted for replacement or repair.



Rebar Cutter - SDS-PLUS SHANK

Part #	Size	OAL	RPM
RBS-6	3/8"	8"	850-1200
RBS-8	1/2"	12"	850-1200
RBS-9	9/16"	12"	850-1200
RBS-10	5/8"	12"	750-1000
RBS-11	11/16"	12"	750-1000
RBS-12	3/4"	12"	600-850
RBS-13	13/16"	12"	600-850
RBS-14	7/8"	12"	600-850
RBS-16	1"	12"	500-750
RBS-18	1-1/8"	12"	500-750
RBS-20	1-1/4"	12"	450-600
RBS-22	1-3/8"	12"	450-600
RBS-24	1-1/2"	12"	350-500

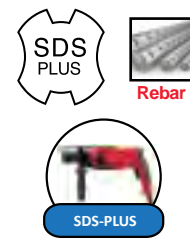

SOLD INDIVIDUALLY
1 PER TUBE.

Rotation Only!



Rebar Cutter - STRAIGHT SHANK

Part #	Size	OAL	RPM
RBC0838	3/8"	8"	850-1200
RBC1212	1/2"	12"	850-1200
RBC1916	9/16"	12"	850-1200
RBC1258	5/8"	12"	750-1000
RBC1116	11/16"	12"	750-1000
RBC1234	3/4"	12"	600-850
RBC1834	3/4"	18"	600-850
RBC1316	13/16"	12"	600-850
RBC1278	7/8"	12"	600-850
RBC1201	1"	12"	500-750
RBC1218	1-1/8"	12"	500-750
RBC1214	1-1/4"	12"	450-600
RBC1238	1-3/8"	12"	450-600
RBC1112	1-1/2"	12"	350-500
RBC1134	1-3/4"	12"	350-500
RBC1202	2"	12"	350-500
RBC1222	2-1/2"	12"	350-500

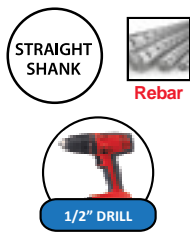

SOLD INDIVIDUALLY
1 PER TUBE.



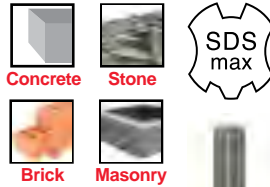

SOLD INDIVIDUALLY.

SDS-MAX® Chisels

Part #	Size	Description
7000BP	12"	Bull Point
7005BP	18"	Bull Point
7010FC	1" x 12"	Flat Chisel
7015FC	1" x 18"	Flat Chisel
7020SC	1-1/2" x 12"	Scaling Chisel
7025SC	2" x 12"	Scaling Chisel
7028SC	2" x 16"	Scaling Chisel
7030SC	3" x 12"	Scaling Chisel
7035AC	2" x 12"	Angled Chisel
7040SL	1-1/8" x 12"	Slotting Chisel
7045BT	1-7/8" x 9-7/8"	Bushing Tool
7050GR	7/8" x 10-1/4"	Ground Rod Driver
7055PH	3-1/2" x 16"	Asphalt Cutter
7065CS	5-3/8" x 16"	Clay Spade
7070FS	6" x 25"	Floor Scraper
7075GC	1" x 12"	Gouge Chisel
FS-6B		Replacement Blade (Floor Scraper)
FS-6NUT		Replacement Nuts & Bolts (Floor Scraper)



Tamping Plate & Shanks

Part #	Size	Description
520MAX	12"	SDS-Max Tamping Shank
550STP	5" Sq.	Tamping Plate

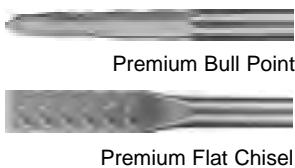

- ◆ Faster!
- ◆ Less Friction
- ◆ Less Jamming
- ◆ Self Sharpening
- ◆ Sold Individually

2X LIFE



Premium Chisels - 2X the Life

Part #	Size	Description	Shank
9004BP	16"	Bull Point	SDS-MAX
9014FC	1" x 16"	Flat Chisel	SDS-MAX
9100BP	10"	Bull Point	SDS-PLUS
9110FC	3/4" x 10"	Flat Chisel	SDS-PLUS

SDS-PLUS Chisels - MINI

Part #	Size	Description
2100BP	5-1/2"	MINI - Bull Point
2110FC	3/4" x 5-1/2"	MINI - Flat Chisel
2115SC	1-1/2" x 5-1/2"	MINI - Scaling Chisel
2244FS	4" x 10"	MINI - Floor Scraper
FS-4B	MINI	Replacement Blade (Floor Scraper)
FS-4NUT	MINI	Replacement Nuts & Bolts (Floor Scraper)

SDS-PLUS Chisels

Part #	Size	Description
3100BP	10"	Bull Point
3110FC	3/4" x 10"	Flat Chisel
3115SC	1-1/2" x 10"	Scaling Chisel
3120GC	7/8" x 10"	Gouge Chisel
3150GR	5/8" x 10"	Ground Rod Driver
3175TC	3" x 6-1/2"	Tile Chisel

Spline Drive Chisels

Part #	Size	Description
5000BP	12"	Bull Point
5005BP	18"	Bull Point
5010FC	1" x 12"	Flat Chisel
5015FC	1" x 18"	Flat Chisel
5020SC	1-1/2" x 12"	Scaling Chisel
5025SC	2" x 12"	Scaling Chisel
5030SC	3" x 12"	Scaling Chisel
5035AC	2" x 12"	Angled Chisel
5040SL	1-1/8" x 12"	Slotting Chisel
5045BT	1-7/8" x 9-7/8"	Bushing Tool
5050GR	7/8" x 10-1/2"	Ground Rod Driver
5055PH	3-1/2" x 16"	Asphalt Cutter
5065CS	5-3/8" x 16"	Clay Spade
5070FS	6" x 25"	Floor Scraper

1-1/8" HEX Chisels - Breaker Hammer

Part #	Size	Description
8020HBP	20"	1-1/8" Hex Bull Point
8030HFC	1-1/4" x 20"	1-1/8" Hex Flat Chisel
8040HSC	3" x 20"	1-1/8" Hex Scaling Chisel
8050HPH	5" x 17"	1-1/8" Hex Asphalt Cutter
8060HGR	1" x 15"	1-1/8" Hex Ground Rod Dr.
8070HCS	5-3/8" x 20"	1-1/8" Hex Clay Spade

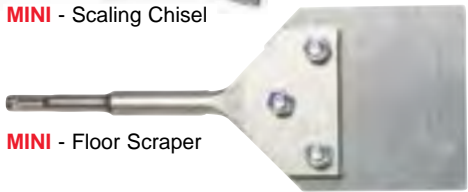
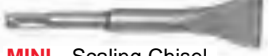
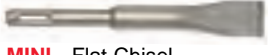

SOLD INDIVIDUALLY.

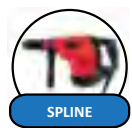

NOTE: Spline Drive chisels have rounded hex shanks to work effectively in Spline Drive machines made with and without rotation / hammer only switches.



- Black & Decker®** 5027
- Bosch®** BRUTE 11304
- Milwaukee®** 5338
- Kango®** 2500
- Hitachi®** H65 - H85 - H905SB
- Makita®** HM1303B HM1500B HM1800
- Wacker®** EH27



1-1/8" HEX Shank Chisels come with Internal locks for Demolition Hammers and External Collars for Pneumatic Hammers.

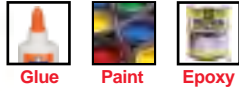

- ◆ For Removal Of Surface Coatings / Porous Ceramic Glue
- ◆ Wet or Dry
- ◆ Will Not Smear Like Diamond Cup Wheel
- ◆ Sold Individually



PCD Cup Wheel

Part #	Size	Arbor	Segments	Qty.
PCD-50	5"	7/8" Open	6	1
PCD-50T	5"	5/8"-11	6	1
PCD-70	7"	7/8" Open	9	1
PCD-70T	7"	5/8"-11	9	1



- ◆ High Diamond Concentration
- ◆ Wet Or Dry
- ◆ 5/8"-11 Thread or 7/8" Open Hole
- ◆ Sold Individually



Diamond Grinding Cup Wheel

Part #	Size	Arbor	Segments	Qty.
GCW-50	5"	7/8" Open	16	1
GCW-50T	5"	5/8"-11	16	1
GCW-70	7"	7/8" Open	18	1
GCW-70T	7"	5/8"-11	18	1



- ◆ High Diamond Concentration
- ◆ Wet Or Dry
- ◆ Fast Aggressive Grinding
- ◆ Smooth Finish
- ◆ 7/8" Open Hole
- ◆ Sold Individually

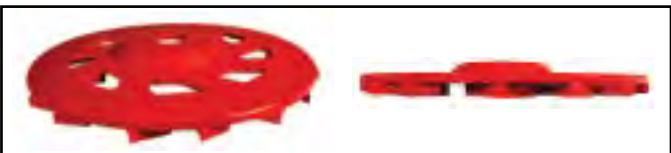

Diamond Turbo Grinding Cup Wheel

Part #	Size	Arbor	Segments	Qty.
TTT-50	5"	7/8" Open	12	1
TTT-70	7"	7/8" Open	18	1

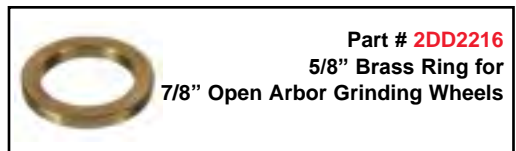

Diamond Cutting Wheels



- ◆ Industrial Quality
- ◆ For Dry & Wet Use
- ◆ Individually Blister Carded

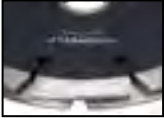

3" SANDWICH TUCK POINT DIAMOND CUTTING WHEEL

<p>Part # DSB-30</p>	<ul style="list-style-type: none"> • DRY TYPE • DIAMETER: 3" ± 0.70MM • TEETH THICKNESS: 0.25" (-0.00/+0.20MM) • 28 CRMO Body / LASER WELDED BLADE • 20MM ROUND ARBOR W/ 5/8" BUSHING ADAPTER (SOLID BRASS) • 20-25% CONCENTRATION OF DIAMOND GRAIN • 13,700 RPM MAXIMUM 	
-----------------------------	---	--



5" SANDWICH TUCK POINT DIAMOND CUTTING WHEEL

<p>Part # DSB-50</p>	<ul style="list-style-type: none"> • DRY TYPE • DIAMETER: 5" ± 0.70MM • TEETH THICKNESS: 0.25" (-0.00/+0.20MM) • 28 CRMO Body / LASER WELDED BLADE • 20MM ROUND ARBOR W/ 5/8" BUSHING ADAPTER (SOLID BRASS) • 20-25% CONCENTRATION OF DIAMOND GRAIN • 13,700 RPM MAXIMUM 	
-----------------------------	---	---



4" TUCK POINT DIAMOND CUTTING WHEEL

<p>Part # TPS40</p>	<ul style="list-style-type: none"> • DRY TYPE • DIAMETER: 4" ± 0.70MM • TEETH THICKNESS: 0.25" (-0.00/+0.20MM) • 28 CRMO Body / LASER WELDED BLADE • 20MM ROUND ARBOR W/ 5/8" BUSHING ADAPTER (SOLID BRASS) • 20-25% CONCENTRATION OF DIAMOND GRAIN • 13,700 RPM MAXIMUM 	
----------------------------	---	--



4-1/2" TUCK POINT DIAMOND CUTTING WHEEL

<p>Part # TPS45</p>	<ul style="list-style-type: none"> • DRY TYPE • DIAMETER: 4-1/2" ± 0.70MM • TEETH THICKNESS: 0.25" (-0.00/+0.20MM) • 28 CRMO Body / LASER WELDED BLADE • 20MM ROUND ARBOR W/ 5/8" BUSHING ADAPTER (SOLID BRASS) • 20-25% CONCENTRATION OF DIAMOND GRAIN • 13,700 RPM MAXIMUM 	
----------------------------	---	--



4" CONTINUOUS RIM DIAMOND CUTTING WHEEL

<p>Part # DCR40</p>	<ul style="list-style-type: none"> • DRY & WET TYPE • DIAMETER: 4" ± 0.70MM • TEETH THICKNESS: 0.08" (-0.00/+0.20MM) • 65MN BODY • 7/8" ROUND ARBOR W/ 20MM & 5/8" BUSHING ADAPTER (SOLID BRASS) • 20-25% CONCENTRATION OF DIAMOND GRAIN • 13,700 RPM MAXIMUM 	
----------------------------	--	--





4-1/2" CONTINUOUS RIM DIAMOND CUTTING WHEEL

Part # **DCR45**

- DRY & WET TYPE
- DIAMETER: 4-1/2" ± 0.70MM
- TEETH THICKNESS: 0.08" (-0.00/+0.20MM)
- 65MN BODY
- 7/8" ROUND ARBOR W/ 20MM & 5/8" BUSHING ADAPTER (SOLID BRASS)
- 20-25% CONCENTRATION OF DIAMOND GRAIN
- 13,300 RPM MAXIMUM



7" CONTINUOUS RIM DIAMOND CUTTING WHEEL

Part # **DCR70**

- DRY & WET TYPE
- DIAMETER: 7" ± 0.70MM
- TEETH THICKNESS: 0.08" (-0.00/+0.20MM)
- 65MN BODY
- 7/8" ROUND ARBOR W/ 20MM & 5/8" BUSHING ADAPTER (SOLID BRASS)
- 20-25% CONCENTRATION OF DIAMOND GRAIN
- 8,400 RPM MAXIMUM



8" CONTINUOUS RIM DIAMOND CUTTING WHEEL

Part # **DCR80**

- DRY & WET TYPE
- DIAMETER: 8" ± 0.70MM
- TEETH THICKNESS: 0.1" (-0.00/+0.20MM)
- 65MN BODY
- 7/8" ROUND ARBOR W/ 20MM & 5/8" RHOMBIC BUSHING ADAPTER (SOLID BRASS)
- 20-25% CONCENTRATION OF DIAMOND GRAIN
- 7,400 RPM MAXIMUM



4" TURBO DIAMOND CUTTING WHEEL

Part # **DTU40**

- DRY & WET TYPE
- DIAMETER: 4" ± 0.70MM
- TEETH THICKNESS: 0.08" (-0.00/+0.20MM)
- 65MN BODY
- 7/8" ROUND ARBOR W/ 20MM & 5/8" BUSHING ADAPTER (SOLID BRASS)
- 20-25% CONCENTRATION OF DIAMOND GRAIN
- 13,700 RPM MAXIMUM



4-1/2" TURBO DIAMOND CUTTING WHEEL

Part # **DTU45**

- DRY & WET TYPE
- DIAMETER: 4-1/2" ± 0.70MM
- TEETH THICKNESS: 0.08" (-0.00/+0.20MM)
- 65MN BODY
- 7/8" ROUND ARBOR W/ 20MM & 5/8" BUSHING ADAPTER (SOLID BRASS)
- 20-25% CONCENTRATION OF DIAMOND GRAIN
- 13,300 RPM MAXIMUM



7" TURBO DIAMOND CUTTING WHEEL

Part # **DTU70**

- DRY & WET TYPE
- DIAMETER: 7" ± 0.70MM
- TEETH THICKNESS: 0.08" (-0.00/+0.20MM)
- 65MN BODY
- 7/8" ROUND ARBOR W/ 20MM & 5/8" BUSHING ADAPTER (SOLID BRASS)
- 20-25% CONCENTRATION OF DIAMOND GRAIN
- 8,400 RPM MAXIMUM

8" TURBO DIAMOND CUTTING WHEEL	
Part # DTU80	<ul style="list-style-type: none"> • DRY & WET TYPE • DIAMETER: 8" ± 0.70MM • TEETH THICKNESS: 0.1" (-0.00/+0.20MM) • 65MN BODY • 7/8" ROUND ARBOR W/ 20MM & 5/8" RHOMBIC BUSHING ADAPTER (SOLID BRASS) • 20-25% CONCENTRATION OF DIAMOND GRAIN • 7,400 RPM MAXIMUM

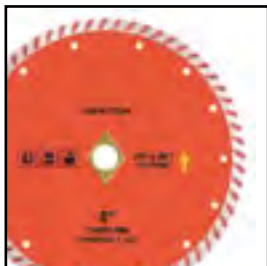

4" SEGMENTED DIAMOND CUTTING WHEEL	
Part # DCS40	<ul style="list-style-type: none"> • DRY TYPE • DIAMETER: 4" ± 0.70MM • TEETH THICKNESS: 0.08" (-0.00/+0.20MM) • 65MN BODY • 7/8" ROUND ARBOR W/ 20MM & 5/8" BUSHING ADAPTER (SOLID BRASS) • 20-25% CONCENTRATION OF DIAMOND GRAIN • 13,700 RPM MAXIMUM



4-1/2" SEGMENTED DIAMOND CUTTING WHEEL	
Part # DCS45	<ul style="list-style-type: none"> • DRY TYPE • DIAMETER: 4-1/2" ± 0.70MM • TEETH THICKNESS: 0.08" (-0.00/+0.20MM) • 65MN BODY • 7/8" ROUND ARBOR W/ 20MM & 5/8" BUSHING ADAPTER (SOLID BRASS) • 20-25% CONCENTRATION OF DIAMOND GRAIN • 13,300 RPM MAXIMUM



7" SEGMENTED DIAMOND CUTTING WHEEL	
Part # DCS70	<ul style="list-style-type: none"> • DRY TYPE • DIAMETER: 7" ± 0.70MM • TEETH THICKNESS: 0.08" (-0.00/+0.20MM) • 65MN BODY • 7/8" ROUND ARBOR W/ 20MM & 5/8" BUSHING ADAPTER (SOLID BRASS) • 20-25% CONCENTRATION OF DIAMOND GRAIN • 8,400 RPM MAXIMUM



12" SEGMENTED DIAMOND CUTTING WHEEL	
Part # DCS120	<ul style="list-style-type: none"> • DRY TYPE • DIAMETER: 12" • TEETH THICKNESS: 0.1" (-0.05/+0.20MM) • TEETH (HIGH): 0.256" (-0.20/+0.70mm) • 65MN BODY • 1" ROUND ARBOR W/ 20MM & 7/8" BUSHING ADAPTER (SOLID BRASS) • 20-25% CONCENTRATION OF DIAMOND GRAIN • 5,000 RPM MAXIMUM
 Part # 2DD191S 14MM Brass Ring for 1" Arbor Diamond Wheels	



14" SEGMENTED DIAMOND CUTTING WHEEL	
Part # DCS140	<ul style="list-style-type: none"> • DRY TYPE • DIAMETER: 14" • TEETH THICKNESS: 0.12" (-0.05/+0.20MM) • TEETH (HIGH): 0.315" (-0.20/+0.70mm) • 65MN BODY • 1" ROUND ARBOR W/ 20MM & 7/8" BUSHING ADAPTER (SOLID BRASS) • 20-25% CONCENTRATION OF DIAMOND GRAIN • 4,300 RPM MAXIMUM
 Part # 2DD191S 14MM Brass Ring for 1" Arbor Diamond Wheels	





Phillips

PHILLIPS POINT #	SHEET METAL SCREWS	WOOD SCREWS		MACHINE SCREWS		
	FLAT, ROUND, OVAL STOVE BINDING	FLAT, OVAL	ROUND	FLAT, OVAL BINDING	ROUND, FILLISTER	TRUSS, BRAZIER BUTTON
0	0, 1	0, 1	0, 1	0, 1	0, 1	0, 1
1	2, 3, 4	2, 3, 4	2, 3, 4	2, 3, 4	2, 3, 4	2, 3, 4, 5
2	5, 6, 7, 8, 10	5, 6, 7, 8, 9	5, 6, 7, 8, 9, 10	5, 6, 8, 10	5, 6, 8, 10	6, 8, 10
3	12, 14	10, 12, 14, 16	12, 14, 16	12, 1/4"	12, 1/4", 5/16"	12, 1/4"

Slotted

SLOTTED POINT #	SCREW SIZE	SLOT SCREW WIDTH		THREAD DIA.	MAXIMUM HEAD DIAMETER					
		MIN.	MAX.		FLAT or OVAL HEAD	ROUND HEAD	FILLISTER HEAD	BINDING HEAD	PAN HEAD	TRUSS HEAD
4-5	3	.027	.035	.099	.199	.187	.161	.208	.193	.226
4-5	4	.031	.039	.112	.225	.211	.183	.235	.219	.257
6-8	5	.035	.043	.125	.252	.236	.205	.263	.245	.289
8-10	6	.039	.048	.138	.279	.260	.226	.290	.270	.321
10-12	8	.045	.054	.164	.332	.309	.270	.344	.322	.384

Square

SQUARE POINT #	TAPPING SCREWS	WOOD SCREWS	MACHINE SCREWS
0	3, 4	3, 4	3, 4
1	5, 6, 7	5, 6, 7	5, 6
2	8, 10	8, 9, 10	8, 10
3	12, 14	12, 14	12, 14

Star **FOR TORX® SCREWS.**

SCREW SIZE	THREAD DIA.	INTERNAL TORX WASHER HEAD	PAN HEAD	FLAT HEAD	HEX HEAD	TRUSS HEAD	FILLISTER HEAD	OVAL HEAD	SOCKET HEAD CAP	SOCKET SET SCREW
2	.086	T7	T7	T6						
3	.099	T8	T8	T7						
4	.112	T9	T9	T8	T9		T9		T10	T6
5	.125	T10	T10	T9	T10		T10	T10	T10	T7
6	.138	T15	T15	T10	T15	T10	T15	T15	T15	T7
8	.164	T20	T20	T15	T20	T15	T20	T20	T25	T8
10	.190	T25	T25	T20	T25	T20	T25	T25	T27	T10
12	.216	T27	T27	T25	T27	T25	T27	T27	T27	T10
1/4"	.250	T30	T30	T27	T30	T27	T30	T30	T30	T20
5/16"	.312			T40	T40	T40	T340	T40	T45	T27
3/8"	.375		T45	T40	T45	T45	T45	T45	T50	T30
7/16"	.437		T50	T50		T45	T50	T50	T55	T40
1/2"	.500		T55	T50		T50	T55	T50	T55	T45



Insert Bit Countertop Dispenser

Part #	Type	Qty.
BITDIS	EMPTY DISPLAY	1

KEEP YOUR INSERT BITS AND NUT SETTERS SAFE AND ORGANIZED.

- ◆ Sold Empty
- ◆ Make Your Own Assortment
- ◆ Display Made In Canada





Phillips® Insert Bits - 1/4" Hex Shank

Part #	Size	OAL	Type	Qty.
T3-025-00	#0 X 1"		PHILLIPS INSERT	25
T3-025-01	#1 X 1"		PHILLIPS INSERT	25
T3-025-02	#2 X 1"		PHILLIPS INSERT	25
T3-025-03	#3 X 1"		PHILLIPS INSERT	25
T3-025-04	#4 X 1"		PHILLIPS INSERT	25



Reduced Body

Phillips® Drywall Bits - 1/4" Hex Shank

Part #	Size	OAL	Type	Qty.
T3-025-1W	#1 X 1"		PHILLIPS DRYWALL	25
T3-025-2W	#2 X 1"		PHILLIPS DRYWALL	25



Phillips® Insert Bits - 5/16" Hex Shank

Part #	Size	OAL	Type	Qty.
T3-032-01	#1 X 1-1/4"		PHILLIPS INSERT	25
T3-032-02	#2 X 1-1/4"		PHILLIPS INSERT	25
T3-032-03	#3 X 1-1/4"		PHILLIPS INSERT	25



Phillips® Stopper - 1/4" Hex Shank

Part #	Size	OAL	Type	Qty.
SP-025-2P	#2 X 1"		PHILLIPS STOPPER	25



Phillips® Power Bits - 1/4" Hex Shank

Part #	Size	OAL	Type	Qty.
T3-050-01	#1 X 2"		PHILLIPS POWER	25
T3-070-01	#1 X 2-3/4"		PHILLIPS POWER	25
T3-075-01	#1 X 3"		PHILLIPS POWER	25
T3-090-01	#1 X 3-1/2"		PHILLIPS POWER	25
T3-100-01	#1 X 4"		PHILLIPS POWER	25
T3-125-01	#1 X 5"		PHILLIPS POWER	25
T3-150-01	#1 X 6"		PHILLIPS POWER	25
T3-050-02	#2 X 2"		PHILLIPS POWER	25
T3-070-02	#2 X 2-3/4"		PHILLIPS POWER	25
T3-075-02	#2 X 3"		PHILLIPS POWER	25
T3-090-02	#2 X 3-1/2"		PHILLIPS POWER	25
T3-100-02	#2 X 4"		PHILLIPS POWER	25
T3-125-02	#2 X 5"		PHILLIPS POWER	25
T3-150-02	#2 X 6"		PHILLIPS POWER	25
T3-050-03	#3 X 2"		PHILLIPS POWER	25
T3-070-03	#3 X 2-3/4"		PHILLIPS POWER	25
T3-075-03	#3 X 3"		PHILLIPS POWER	25
T3-090-03	#3 X 3-1/2"		PHILLIPS POWER	25
T3-100-03	#3 X 4"		PHILLIPS POWER	25
T3-125-03	#3 X 5"		PHILLIPS POWER	25
T3-150-03	#3 X 6"		PHILLIPS POWER	25



Reduced Body

Phillips® Drywall Bits

Part #	Size	OAL	Type	Qty.
T3-050-2W	#2 X 2"		PHILLIPS DRYWALL	25
T3-070-2W	#2 X 2-3/4"		PHILLIPS DRYWALL	25
T3-090-2W	#2 X 3-1/2"		PHILLIPS DRYWALL	25



Phillips® ACR® Insert Bits - 1/4" Hex

Part #	Size	OAL	Type	Qty.
ACR-025-01	#1 X 1"		PHILLIPS ACR INSERT	25
ACR-025-02	#2 X 1"		PHILLIPS ACR INSERT	25
ACR-025-03	#3 X 1"		PHILLIPS ACR INSERT	25



Phillips® ACR® Power Bits - 1/4" Hex

Part #	Size	OAL	Type	Qty.
ACR-050-01	#1 X 2"		PHILLIPS ACR POWER	25
ACR-050-02	#2 X 2"		PHILLIPS ACR POWER	25
ACR-050-03	#3 X 2"		PHILLIPS ACR POWER	25



For Torx® Screws

Star Insert Bits - 1/4" Hex Shank

Part #	Size	OAL	Type	Qty.
TX-025-06	T6	X 1"	STAR INSERT	25
TX-025-07	T7	X 1"	STAR INSERT	25
TX-025-08	T8	X 1"	STAR INSERT	25
TX-025-09	T9	X 1"	STAR INSERT	25
TX-025-10	T10	X 1"	STAR INSERT	25
TX-025-15	T15	X 1"	STAR INSERT	25
TX-025-20	T20	X 1"	STAR INSERT	25
TX-025-25	T25	X 1"	STAR INSERT	25
TX-025-27	T27	X 1"	STAR INSERT	25
TX-025-30	T30	X 1"	STAR INSERT	25
TX-025-40	T40	X 1"	STAR INSERT	25



Square Insert Bits - 1/4" Hex Shank

Part #	Size	OAL	Type	Qty.
T3-R25-00	#0	X 1"	SQUARE INSERT	25
T3-R25-01	#1	X 1"	SQUARE INSERT	25
T3-R25-02	#2	X 1"	SQUARE INSERT	25
T3-R25-03	#3	X 1"	SQUARE INSERT	25



For Torx® Screws

Star Power Bits - 5/16" Hex Shank

Part #	Size	OAL	Type	Qty.
TX-032-30	T30	X 1-1/4"	STAR POWER	25
TX-032-40	T40	X 1-1/4"	STAR POWER	25
TX-032-45	T45	X 1-1/4"	STAR POWER	25
TX-032-50	T50	X 1-1/4"	STAR POWER	25
TX-032-55	T55	X 1-1/4"	STAR POWER	25



For Torx® Screws

Star Power Bits - 1/4" Hex Shank

Part #	Size	OAL	Type	Qty.
TX-050-10	T10	X 2"	STAR POWER	25
TX-150-10	T10	X 6"	STAR POWER	25
TX-050-15	T15	X 2"	STAR POWER	25
TX-150-15	T15	X 6"	STAR POWER	25
TX-050-20	T20	X 2"	STAR POWER	25
TX-150-20	T20	X 6"	STAR POWER	25
TX-050-25	T25	X 2"	STAR POWER	25
TX-150-25	T25	X 6"	STAR POWER	25
TX-050-27	T27	X 2"	STAR POWER	25
TX-150-27	T27	X 6"	STAR POWER	25
TX-050-30	T30	X 2"	STAR POWER	25
TX-150-30	T30	X 6"	STAR POWER	25
TX-050-40	T40	X 2"	STAR POWER	25
TX-150-40	T40	X 6"	STAR POWER	25



Square Power Bits - 1/4" Hex Shank

Part #	Size	OAL	Type	Qty.
T3-R50-01	#1	X 2"	SQUARE POWER	25
T3-R70-01	#1	X 2-3/4"	SQUARE POWER	25
T3-R75-01	#1	X 3"	SQUARE POWER	25
T3-R90-01	#1	X 3-1/2"	SQUARE POWER	25
T3-R10-01	#1	X 4"	SQUARE POWER	25
T3-R12-01	#1	X 5"	SQUARE POWER	25
T3-R15-01	#1	X 6"	SQUARE POWER	25
T3-R50-02	#2	X 2"	SQUARE POWER	25
T3-R70-02	#2	X 2-3/4"	SQUARE POWER	25
T3-R75-02	#2	X 3"	SQUARE POWER	25
T3-R90-02	#2	X 3-1/2"	SQUARE POWER	25
T3-R10-02	#2	X 4"	SQUARE POWER	25
T3-R12-02	#2	X 5"	SQUARE POWER	25
T3-R15-02	#2	X 6"	SQUARE POWER	25
T3-R50-03	#3	X 2"	SQUARE POWER	25
T3-R70-03	#3	X 2-3/4"	SQUARE POWER	25
T3-R75-03	#3	X 3"	SQUARE POWER	25
T3-R90-03	#3	X 3-1/2"	SQUARE POWER	25
T3-R10-03	#3	X 4"	SQUARE POWER	25
T3-R12-03	#3	X 5"	SQUARE POWER	25
T3-R15-03	#3	X 6"	SQUARE POWER	25



Quick Change Extensions
P. 76

- ◆ S2 Modified Steel
- ◆ Rc. 58-62 Heat Treated
- ◆ German Grade Steel





Pozidriv® Insert Bits - 1/4" Hex Shank

Part #	Size	OAL	Type	Qty.
PZ-025-01	#1 X 1"		POZIDRIV INSERT	25
PZ-025-02	#2 X 1"		POZIDRIV INSERT	25
PZ-025-03	#3 X 1"		POZIDRIV INSERT	25



Pozidriv® Power Bits - 1/4" Hex Shank

Part #	Size	OAL	Type	Qty.
PZ-050-01	#1 X 2"		POZIDRIV POWER	25
PZ-050-02	#2 X 2"		POZIDRIV POWER	25
PZ-075-02	#2 X 3"		POZIDRIV POWER	25
PZ-050-03	#3 X 2"		POZIDRIV POWER	25



Slotted Insert Bits - 1/4" Hex Shank

Part #	Size	OAL	Type	Qty.
ST-025-04	#4-5 X 1"		SLOTTED INSERT	25
ST-025-08	#6-8 X 1"		SLOTTED INSERT	25
ST-025-10	#8-10 X 1"		SLOTTED INSERT	25
ST-025-12	#10-12 X 1"		SLOTTED INSERT	25



Slotted Power Bits - 1/4" Hex Shank

Part #	Size	OAL	Type	Qty.
ST-050-04	#4-5 X 2"		SLOTTED POWER	25
ST-050-08	#6-8 X 2"		SLOTTED POWER	25
ST-050-10	#8-10 X 2"		SLOTTED POWER	25
ST-070-10	#8-10 X 3"		SLOTTED POWER	25
ST-090-10	#8-10 X 3-1/2"		SLOTTED POWER	25
ST-050-12	#10-12 X 2"		SLOTTED POWER	25

- ◆ S2 Modified Steel
- ◆ Rc. 58-62 Heat Treated
- ◆ German Grade Steel



Hex Insert Bits - 1/4" Hex Shank

Part #	Size	OAL	Type	Qty.
HE-25-564	5/64" X 1"		HEX INSERT	25
HE-25-332	3/32" X 1"		HEX INSERT	25
HE-25-764	7/64" X 1"		HEX INSERT	25
HE-25-864	1/8" X 1"		HEX INSERT	25
HE-25-532	5/32" X 1"		HEX INSERT	25
HE-25-316	3/16" X 1"		HEX INSERT	25



Hex Insert Bits - 5/16" Hex Shank

Part #	Size	OAL	Type	Qty.
HE-32-316	3/16" X 1-1/4"		HEX INSERT	25
HE-32-732	7/32" X 1-1/4"		HEX INSERT	25
HE-32-014	1/4" X 1-1/4"		HEX INSERT	25



Double End Bits - 1/4" Hex Shank

Part #	Size	Qty.
DW-050-22	#2 PHILLIPS / #2 PHILLIPS	25
DW-050-26	#2 PHILLIPS / #6-8 SLOTTED	25
DW-050-28	#2 PHILLIPS / #8-10 SLOTTED	25



Phillips® Impact Bits - 1/4" Hex Shank

Part #	Size	OAL	Type	Qty.
BLU-025-02	#2 X 1-3/16"		PHILLIPS IMPACT	25
BLU-050-02	#2 X 2"		PHILLIPS IMPACT	25
BLU-025-03	#3 X 1-3/16"		PHILLIPS IMPACT	25
BLU-050-03	#3 X 2"		PHILLIPS IMPACT	25





Spanner Insert Bits - 1/4" Hex Shank

Part #	Size	OAL	Type	Qty.
SP-025-06	#6 X 1"		SPANNER	25
SP-025-08	#8 X 1"		SPANNER	25
SP-025-10	#10 X 1"		SPANNER	25
SP-025-12	#12 X 1"		SPANNER	25
SP-025-14	#14 X 1"		SPANNER	25



Hex Tamper Insert Bits - 1/4" Hex

Part #	Size	OAL	Type	Qty.
TH-25-332	3/32" X 1"		HEX TAMPER	25
TH-25-018	1/8" X 1"		HEX TAMPER	25
TH-25-964	9/64" X 1"		HEX TAMPER	25
TH-25-532	5/32" X 1"		HEX TAMPER	25
TH-25-316	3/16" X 1"		HEX TAMPER	25
TH-25-732	7/32" X 1"		HEX TAMPER	25
TH-25-014	1/4" X 1"		HEX TAMPER	25
TH-25-516	5/16" X 1"		HEX TAMPER	25



For TAMPER RESISTANT Torx® Screws

Star Tamper Insert Bits - 1/4" Hex

Part #	Size	OAL	Type	Qty.
TT-025-08	T8 X 1"		STAR TAMPER	25
TT-025-09	T9 X 1"		STAR TAMPER	25
TT-025-10	T10 X 1"		STAR TAMPER	25
TT-025-15	T15 X 1"		STAR TAMPER	25
TT-025-20	T20 X 1"		STAR TAMPER	25
TT-025-25	T25 X 1"		STAR TAMPER	25
TT-025-27	T27 X 1"		STAR TAMPER	25
TT-025-30	T30 X 1"		STAR TAMPER	25
TT-025-40	T40 X 1"		STAR TAMPER	25



Tri-Wing® Tamper Insert Bits - 1/4" Hex

Part #	Size	OAL	Type	Qty.
TRI-25-01	#1 X 1"		TRI-WING	25
TRI-25-02	#2 X 1"		TRI-WING	25
TRI-25-03	#3 X 1"		TRI-WING	25



For TAMPER RESISTANT Torx® Screws

Star Tamper Insert Bits - 5/16" Hex

Part #	Size	OAL	Type	Qty.
TT-032-45	T45 X 1-1/4"		STAR TAMPER	25
TT-032-50	T50 X 1-1/4"		STAR TAMPER	25
TT-032-55	T55 X 1-1/4"		STAR TAMPER	25



Phillips® Tamper Insert Bits - 1/4" Hex

Part #	Size	OAL	Type	Qty.
TP-025-02	#2 X 1"		PHILLIPS TAMPER	25
TP-025-03	#3 X 1"		PHILLIPS TAMPER	25

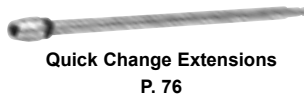
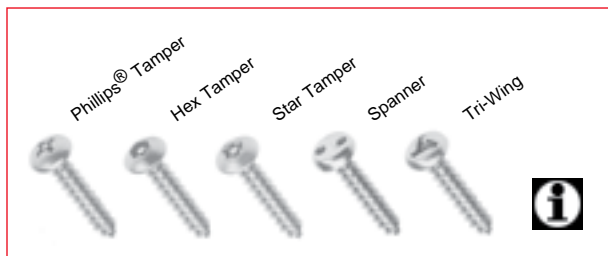

- ◆ S2 Modified Steel
- ◆ Rc. 58-62 Heat Treated
- ◆ German Grade Steel





SOLD INDIVIDUALLY.

Bit Holders - Stainless Steel - Magnetic

Part #	OAL	Body Dia.	Retaining Ring	Description
BH-020-RC	1-3/4"	7/16"	NO	2PC. CONSTRUCTION

Part #	OAL	Body Dia.	Retaining Ring	Description
BH-040-RC	1-13/16"	7/16"	YES	1PC. CONSTRUCTION

BLUE SHOCK



Made in Germany

Part #	OAL	Body Dia.	Retaining Ring	Description
BH-060-BLU	2-1/2"	7/16"	YES	2PC. CONSTRUCTION

Part #	OAL	Body Dia.	Retaining Ring	Description
BH-060-RC	2-5/8"	7/16"	YES	1PC. CONSTRUCTION

BH-060-40 made of Chrome Vanadium.

Part #	OAL	Body Dia.	Retaining Ring	Description
BH-060-40	2-5/8"	3/8"	NO	2PC. CONSTRUCTION

Part #	OAL	Body Dia.	Retaining Ring	Description
BH-075-14	3"	7/16"	NO	2PC. CONSTRUCTION

Part #	OAL	Body Dia.	Retaining Ring	Description
BH-075-14R	3"	7/16"	YES	2PC. CONSTRUCTION

Part #	OAL	Body Dia.	Retaining Ring	Description
BH-075-RC	3"	7/16"	YES	1PC. CONSTRUCTION

Part #	OAL	Body Dia.	Retaining Ring	Description
BH-100-TR	3"	7/16"	THREADED	1PC. CONSTRUCTION

Part #	OAL	Body Dia.	Retaining Ring	Description
BH-100-RC	4"	7/16"	YES	1PC. CONSTRUCTION

Part #	OAL	Body Dia.	Retaining Ring	Description
BH-150-RC	6"	7/16"	YES	1PC. CONSTRUCTION

SOLD INDIVIDUALLY.



5/16" Bit Holders - Stainless Steel - Magnetic

Part #	OAL	Body Dia.	Retaining Ring	Description
LBH-1	3-1/2"	1/2"	YES	2PC. CONSTRUCTION
LBH-2	3"	1/2"	YES	1PC. CONSTRUCTION

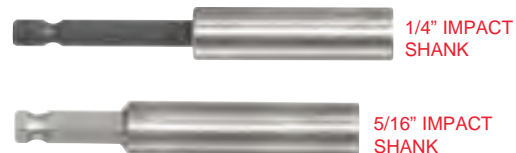

Bit Holders - Special Application - Magnetic

Part #	OAL	Body Dia.	Retaining Ring	Description
BH-050-LK	2"	9/16"	YES / LOCK	SNAP LOCK HOLDER
BH-075-LK	3"	9/16"	YES / LOCK	SNAP LOCK HOLDER



Part #	OAL	Body Dia.	Retaining Ring	Description
BH-075-SL	3"	7/16"	NO	SLEEVE GUIDE HOLDER
BH-125-SL	5"	7/16"	NO	SLEEVE GUIDE HOLDER



Part #	OAL	Body Dia.	Retaining Ring	Description
FX-075-01	7-1/4"	1/2"	YES / BALL	FLEXIBLE BIT HOLDER



Part #	OAL	Body Dia.	Retaining Ring	Description
QUI0001	1-3/4"	13/16"	LOCK	METAL/SPRING OUT



Lag Driver / Ceiling Tile Hanger Driver

Part #	OAL	Body Dia.	Driver Size	Description
CE-075-14SL	2-1/2"	5/8"	7/16"	LAG DRIVER WITH SLEEVE



For eye lag screws to install suspended drop down ceilings.

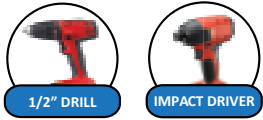

SOLD INDIVIDUALLY.



1/4"
DRIVE

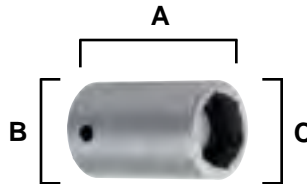

1/4" Square Drive Extension

Part #	OAL
AD-025-14	1"
AD-032-14	1-1/4"
AD-050-14	2"
AD-075-14	3"
AD-100-14	4"
AD-150-14	5"
AD-200-14	6"

1/4" Square Drive Impact Sockets

Part #	Hex Size	Length (A)	Body (B)	Nose (C)
250ST1264	3/16"	15/16"	1/2"	3/8"
250ST1664	1/4"	15/16"	1/2"	7/16"
250ST2064	5/16"	15/16"	1/2"	1/2"
250ST2464	3/8"	1"	5/8"	9/16"
250ST3264	1/2"	1"	3/4"	3/4"



3/8"
DRIVE

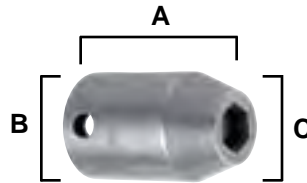

3/8" Square Drive Extension

Part #	OAL
AD-050-38	2"
AD-075-38	3"
AD-100-38	4"
AD-150-38	6"
AD-200-38	8"

3/8" Square Drive Impact Sockets

Part #	Hex Size	Length (A)	Body (B)	Nose (C)
375ST1664	1/4"	1-1/4"	3/4"	7/16"
375ST2064	5/16"	1-1/4"	3/4"	1/2"
375ST2464	3/8"	1-1/4"	3/4"	9/16"
375ST3264	1/2"	1-1/2"	15/16"	3/4"



1/2"
DRIVE

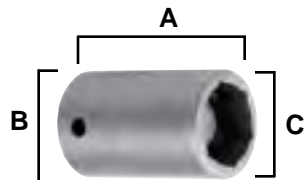

1/2" Square Drive Extension

Part #	OAL
AD-055-12	2-1/8"
AD-075-12	3"
AD-150-12	6"
AD-200-12	8"

1/2" Square Drive Impact Sockets

Part #	Hex Size	Length (A)	Body (B)	Nose (C)
500ST1664	1/4"	1-1/2"	15/16"	7/16"
500ST2064	5/16"	1-1/2"	15/16"	1/2"
500ST2464	3/8"	1-1/2"	15/16"	9/16"
500ST3264	1/2"	1-1/2"	15/16"	3/4"



Nut Setters - Magnetic Impact Protection

Part #	Hex Head Size	X	OAL	Type	Qty.
IMP-042-16	1/4"	X	1-3/4"	MAG. IMPACT	10
IMP-065-16	1/4"	X	2-9/16"	MAG. IMPACT	10
IMP-075-16	1/4"	X	4"	MAG. IMPACT	5
IMP-085-16	1/4"	X	6"	MAG. IMPACT	5
IMP-042-20	5/16"	X	1-3/4"	MAG. IMPACT	10
IMP-065-20	5/16"	X	2-9/16"	MAG. IMPACT	10
IMP-075-20	5/16"	X	4"	MAG. IMPACT	5
IMP-085-20	5/16"	X	6"	MAG. IMPACT	5
IMP-042-24	3/8"	X	1-3/4"	MAG. IMPACT	10
IMP-065-24	3/8"	X	2-9/16"	MAG. IMPACT	10
IMP-075-24	3/8"	X	4"	MAG. IMPACT	5
IMP-085-24	3/8"	X	6"	MAG. IMPACT	5
IMP-085-40	9/16"	X	6"	MAG. IMPACT	5

- ◆ 1/4" Hex Impact Shank
- ◆ Made for Powerful Impact Drivers / Wrenches
- ◆ 1pc Construction
- ◆ Industrial Grade Magnet



1-3/4" Long



2-9/16" Long



4" Long



Nut Setters - Magnetic (Standard)

Part #	Hex Head Size	X	OAL	Type	Qty.
NS-042-16	1/4"	X	1-3/4"	MAG. NUT SETTER	10
NS-053-16	1/4"	X	2-1/8"	MAG. NUT SETTER	10
NS-065-16	1/4"	X	2-9/16"	MAG. NUT SETTER	10
NS-075-16	1/4"	X	4"	MAG. NUT SETTER	5
NS-085-16	1/4"	X	6"	MAG. NUT SETTER	5
NS-042-20	5/16"	X	1-3/4"	MAG. NUT SETTER	10
NS-053-20	5/16"	X	2-1/8"	MAG. NUT SETTER	10
NS-065-20	5/16"	X	2-9/16"	MAG. NUT SETTER	10
NS-075-20	5/16"	X	4"	MAG. NUT SETTER	5
NS-085-20	5/16"	X	6"	MAG. NUT SETTER	5
NS-042-24	3/8"	X	1-3/4"	MAG. NUT SETTER	10
NS-053-24	3/8"	X	2-1/8"	MAG. NUT SETTER	10
NS-065-24	3/8"	X	2-9/16"	MAG. NUT SETTER	10
NS-075-24	3/8"	X	4"	MAG. NUT SETTER	5
NS-085-24	3/8"	X	6"	MAG. NUT SETTER	5
NS-042-28	7/16"	X	1-3/4"	MAG. NUT SETTER	5
NS-053-28	7/16"	X	2-1/8"	MAG. NUT SETTER	5
NS-065-28	7/16"	X	2-9/16"	MAG. NUT SETTER	5
NS-042-32	1/2"	X	1-3/4"	MAG. NUT SETTER	5
NS-065-32	1/2"	X	2-9/16"	MAG. NUT SETTER	5

- ◆ 1/4" Hex Impact Shank
- ◆ 1pc Construction
- ◆ Industrial Grade Magnet



1-3/4" Long



2-1/8" Long



2-9/16" Long



4" Long

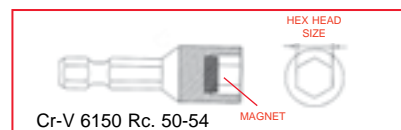



COMES WITH CASE AND HANDLE!



30 Pc. Screwdriver Insert Set - STANDARD

Part #	Description
ST-100-30	<ul style="list-style-type: none"> ⊕ Phillips: #1, #2, #3 ⊖ Slotted: 3-4, 4-5, 6-8, 8-10 ⊕ Posidriv: #1, #2, #3 ⊖ Square: #0, #1, #2, #3 ⊖ Hex: 5/64", 3/32", 7/64", 1/8", 9/64" ⊖ Star: T10, T15, T20, T25, T27, T30, T40 ● 1" Long Socket Adaptor ● 3" Long Bit Holder

COMES WITH CASE AND HANDLE!



30 Pc. Screwdriver Insert Set - TAMPER PROOF

Part #	Description
TR-100-30	<ul style="list-style-type: none"> ⊕ Spanner: #6, #8, #10 ⊕ Posidriv: #1, #2, #3 ⊖ Tri-Wing: #1, #2, #3 ⊖ Hex Tamper: 3/32", 1/8", 9/64", 5/32", 3/16", 7/32", 1/4", 5/16" ⊖ Star Tamper: T8, T9, T10, T15, T20, T25, T27, T30, T40 ● 1" Long Socket Adaptor ● 3" Long Bit Holder



32 Pc. Screwdriver Insert Set - STANDARD

Part #	Description
TECH-32	<ul style="list-style-type: none"> ⊕ Phillips: #0, #1, #2 (2), #3, #2DW (2) ⊖ Slotted: 6-8, 8-10, 10-12 ⊖ Square: #0, #1, #2 (3), #3 ⊖ Hex: 5/64", 3/32", 7/64", 1/8", 5/32", 3/16" ⊖ Star: T8, T10, T15, T20, T25, T27, T30, T40 ● 1/4" Impact Driver Adaptor ● 1/4" Auto Locking Magnetic Bit Holder



← Belt Clip



32 Pc. Screwdriver Insert Set - TAMPER PROOF

Part #	Description
TECH-32TR	<ul style="list-style-type: none"> ⊕ Spanner: #6, #8, #10, #12, #14 ⊖ Star Tamper: T8, T9, T10, T15, T20, T25, T27, T30, T40 ⊖ Hex Tamper: 3/32", 1/8", 9/64", 5/32", 3/16", 7/32", 1/4", 5/16" ⊖ Tri-Wing: #1, #2, #3 ⊖ Square: #1, #2, #3 ⊕ Phillips: #2, #3 ● 1/4" Impact Driver Adaptor ● 1/4" Auto Locking Magnetic Bit Holder

US PATENT 5265504

Made In

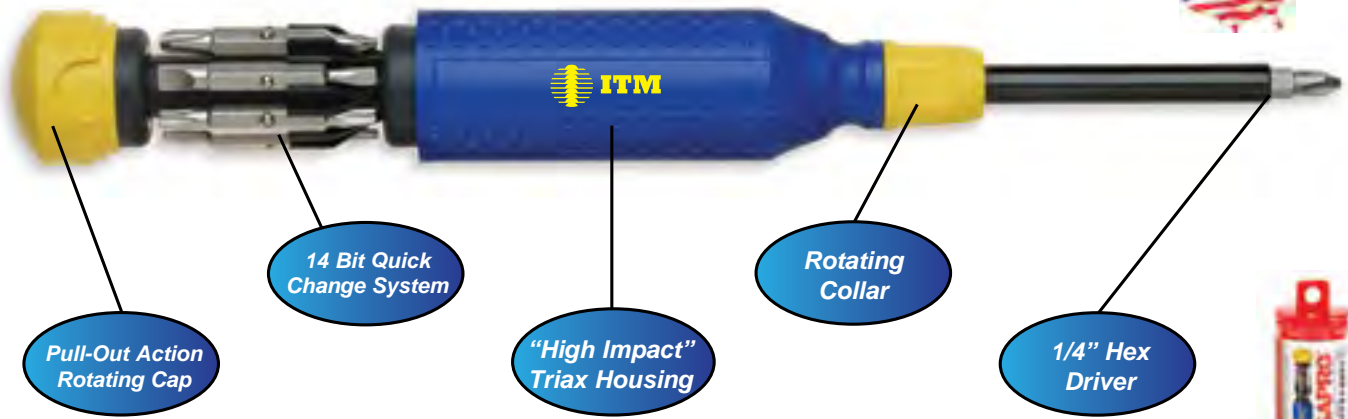

Part #	Description
MEGAPRO151	15-IN-1 MEGAPRO SCREWDRIVER #0 - #3 PHILLIPS #10 - #15 STAR #1 - #2 PHILLIPS #20 - #25 STAR #0 - #3 SQUARE #4 - #6 SLOTTED #1 - #2 SQUARE

Part #	Description
MEGATAM151	15-IN-1 TAMPERPROOF SCREWDRIVER #6 - #8 SPANNER #10 - #15 STAR PIN #10 - #12 SPANNER #20 - #25 STAR PIN 1/8" - 9/64" HEX PIN #27 - #30 STAR PIN 5/32" - 3/16" HEX PIN



Tamper Proof Tamper Proof Driver sold Individually Tubed.

Part #	Description
470001	#0 - #3 PHILLIPS®
470002	#1 - #2 PHILLIPS®
470003	#0 - #3 SQUARE
470004	#1 - #2 SQUARE
470005	#10 - #15 STAR
470006	#20 - #25 STAR
470009	#27 - #30 STAR (SPECIAL SIZE)
470007	#4 - #6 SLOTTED
690001	#6 - #8 SPANNER
690002	#10 - #12 SPANNER
690003	1/8" - 9/64" HEX PIN
690004	5/32" - 3/16" HEX PIN
690005	#10 - #15 STAR PIN
690006	#20 - #25 STAR PIN
690007	#27 - #30 STAR PIN

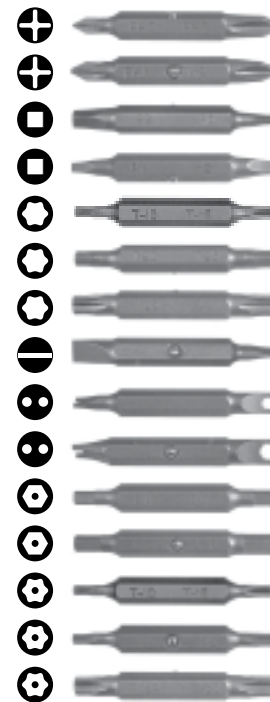

Replacement bits for the Megapro & Megapro Tamper Proof are sold individually.



- ◆ Manufactured of 100% Nylon
- ◆ Non-Corrosive
- ◆ Specification: Type 6.6 Nylon
- ◆ Self-Extinguishing
- ◆ Natural & Weather Resistant Black Operating Temperatures From 40° F (-40° C) to 185° F (85° C).
- ◆ Recognized Under the Components Program of Underwriter Laboratories, Inc.

NATURAL NYLON 6.6 CABLE TIES

Part #	Length	Tensile Strength	Width	Bundle Diameter	Military Specification	Pack Qty.
MS0016-C	4"	18 lbs.	3/32"	1/16" → 5/8"	MS-3367-4-9	100
MS0032-C	5.5"	40 lbs.	1/8"	1/16" → 1-1/4"	MS-3367-5-9	100
MS0050-C	8"	50 lbs.	1/8"	1/16" → 2-1/8"	MS-3367-1-9	100
MS0070-C	11"	50 lbs.	3/16"	1/16" → 3"	MS-3367-7-9	100
MS0108-C	15"	50 lbs.	3/16"	1/16" → 4"	MS-3367-2-9	100

NATURAL NYLON 6.6 CABLE TIES - EXTRA HEAVY DUTY

Part #	Length	Tensile Strength	Width	Bundle Diameter	Military Specification	Pack Qty.
XMS0050	8"	120 lbs.	5/16"	3/16" → 2"	-	100
XMS0070	11"	120 lbs.	5/16"	3/16" → 3"	-	100
XMS0108	15"	120 lbs.	5/16"	3/16" → 4"	-	100
XMS0152	24"	175 lbs.	3/8"	3/16" → 7"	-	100
XMS0225	36"	175 lbs.	3/8"	3/16" → 10"	-	100
XMS0300	48"	175 lbs.	3/8"	3/16" → 12"	-	100

File # E 57800.

BLACK WEATHER RESISTANT NYLON CABLE TIES



Part #	Length	Tensile Strength	Width	Bundle Diameter	Military Specification	Pack Qty.
BWR0016-C	4"	18 lbs.	3/32"	1/16" → 5/8"	MS-3367-4-0	100
BWR0032-C	5.5"	40 lbs.	1/8"	1/16" → 1-1/4"	MS-3367-5-0	100
BWR0050-C	8"	50 lbs.	1/8"	1/16" → 2-1/8"	MS-3367-1-0	100
BWR0070-C	11"	50 lbs.	3/16"	1/16" → 3"	MS-3367-7-0	100
BWR0108-C	15"	50 lbs.	3/16"	1/16" → 4"	MS-3367-2-0	100

BLACK WEATHER RESISTANT NYLON CABLE TIES - EXTRA H.D.

Part #	Length	Tensile Strength	Width	Bundle Diameter	Military Specification	Pack Qty.
XBWR050	8"	120 lbs.	5/16"	3/16" → 2"	-	100
XBWR070	11"	120 lbs.	5/16"	3/16" → 3"	-	100
XBWR108	15"	120 lbs.	5/16"	3/16" → 4"	-	100
XBWR152	24"	175 lbs.	3/8"	3/16" → 7"	-	100
XBWR225	36"	175 lbs.	3/8"	3/16" → 10"	-	100
XBWR300	48"	175 lbs.	3/8"	3/16" → 12"	-	100

CABLE TIE WITH SCREW MOUNT HOLE

Part #	Length	Tensile Strength	Width	Bundle Diameter	Military Specification	Pack Qty.
NATURAL						
WCM0050	8"	50 lbs.	1/8"	1/16" → 2-1/8"	-	100
WCM0070	11"	50 lbs.	3/16"	1/16" → 3"	-	100
WCM0108	14"	50 lbs.	3/16"	1/16" → 4"	-	100
BLACK						
BCM0050	8"	50 lbs.	1/8"	1/16" → 2-1/8"	-	100
BCM0070	11"	50 lbs.	3/16"	1/16" → 3"	-	100
BCM0108	14"	50 lbs.	3/16"	1/16" → 4"	-	100



CONICAL ANCHOR - BLUE

PART# 807AK0010
 100 pcs. - 3/16" Conical Anchors
 100 pcs. - #8 Combo Screws
 1 pc. - 3/16" Slow Spiral Masonry

PART# 807AK0011
 100 pcs. - 1/4" Conical Anchors
 100 pcs. - #10 Combo Screws
 1 pc. - 1/4" Slow Spiral Masonry

PART# 807AK0013
 50 pcs. - 5/16" Conical Anchors
 50 pcs. - #12 Combo Screws
 1 pc. - 5/16" Slow Spiral Masonry



SUPER ANCHOR - YELLOW

PART# SUPRAK006
 100 pcs. - 3/16" SUPER Anchors
 100 pcs. - #8 Combo Screws
 1 pc. - 3/16" Slow Spiral Masonry

PART# SUPRAK008
 100 pcs. - 1/4" SUPER Anchors
 100 pcs. - #10 x 1 1/4" Combo Screws
 1 pc. - 1/4" Slow Spiral Masonry

PART# SUPRAK009
 50 pcs. - 5/16" SUPER Anchors
 50 pcs. - #12 x 1 1/2" Combo Screws
 1 pc. - 5/16" Slow Spiral Masonry



ZAP-IN ANCHOR

PART# EZZ-PACK
 50 pcs. - Zinc Zap-In
 50 pcs. - #8 x 1" Combo Screws
 1 pc. - #2 X 2" Phillips Bit



COMBO SCREW

Anchor Kits



ZAP-IN Anchors

Part #	OAL	Description	Box Qty.	Packaged
EZZ1212	1-5/16"	ZAP IN ZAMAC ALLOY	100	BOX
EZZ1212B	1-5/16"	ZAP IN ZAMAC ALLOY	2,000	BULK
EZN1212	1-3/4"	ZAP IN NYLON	100	BOX
EZN1212B	1-3/4"	ZAP IN NYLON	2,000	BULK

- ◆ Industrial Quality
- ◆ Ideal for Fastening to Drywall and Other Low Density Substrates
- ◆ Easily Removable by Simply Backing Out Screw



Hammer Drive Nail-In Anchors - Zamac

Part #	Size	Description	Drill	Box Qty.
HD14010	1/4" X 1"	MUSHROOM	1/4"	100
HD14114	1/4" X 1-1/4"	MUSHROOM	1/4"	100
HD14112	1/4" X 1-1/2"	MUSHROOM	1/4"	100

Meets or exceeds GSA Specification FF-S-325, Group V, Type 2, Class 3.

EASY TO INSTALL

No screws necessary. Just drill 1/4" hole and hammer in the anchor.

- Hollow Wall
- Solid Wall
- Concrete
- Stone
- Brick
- Plaster
- Sheet Metal



Split Drive Anchors - Zinc Plated

Part #	Size	Minimum Embedment	Drill	Box Qty.
FDA14150	1/4" X 1-1/2"	1-1/8"	1/4"	100
FDA14200	1/4" X 2"	1-1/8"	1/4"	100
FDA14250	1/4" X 2-1/2"	1-1/8"	1/4"	100
FDA14300	1/4" X 3"	1-1/8"	1/4"	100
FDA14350	1/4" X 3-1/2"	1-1/8"	1/4"	100
FDA14400	1/4" X 4"	1-1/8"	1/4"	100

Meets or exceeds GSA Specification FF-S-325, Group IV.

EASY TO INSTALL

No screws necessary. Just drill 1/4" hole and hammer in the anchor.

- ◆ Carbon Steel Construction
- ◆ Flat Head
- Concrete
- Stone
- Solid Brick



- ◆ Retractable 3 Blade Positions
- ◆ Extra Blade Inside Compartment
- ◆ Carded and Sold Individually



Carded Utility Knife - 1 Pack

Part #	Description
UTK0001	UTILITY KNIFE

- ◆ Retractable 3 Blade Positions
- ◆ 3 Blades In Each Knife
- ◆ Heavy Duty Die Cast Aluminum
- ◆ Pull Out Mechanism For Quick Blade Change

FREE COUNTER DISPLAY WITH EVERY ORDER.



Quick Release Utility Knife - 12 Pack

Part #	Description
UTK0002	UTILITY KNIFE (12 PK)

- ◆ Double Sided Tooth Geometry
- ◆ Narrow Blade Ideal For Awkward Cuts
- ◆ Carded And Sold Individually



6" Wallboard Saw - 1 Pack

Part #	Description
WS-6	6" WALLBOARD SAW

- ◆ 6 in 1 Quick Change
- ◆ Industrial Quality

SOLD IN 12 PIECE DISPLAY BOX ONLY.



6-IN-1 Combination Screwdriver

Part #	Description
ST-100-20	6-IN-1 SCREWDRIVER #1, #2, PHILLIPS 1/4" NUT SETTER #5, #8-10, SLOTTED 5/16" NUT SETTER

- ◆ Heavy Duty
- ◆ Fits All Standard Knives
- ◆ Made in Taiwan



Heavy Duty Utility Blades

Part #	Description	Qty.
HDB9005	INDIVIDUAL PACK	5
HDB9100	100 PACK (20 X 5 PACKS)	100
HDB9100-HOOK	100 PACK - DOUBLE HOOK	100

Safety Goggles

Part #	Description	Qty.
GOG0001	SAFETY GOGGLES	1