



# Magnetic Filtration Systems

Sub-micron filtration for industrial fluids in precision machining & wash system applications



INNOVATIVE SOLUTIONS

LEAN MANUFACTURING



KAIZEN

VALUE ADDED SAVINGS



TIME SAVINGS



# 100 years of innovation



## Innovation in magnetics

Our magnetic technology is widely used at leading worldwide companies and in major development projects, all requiring a guarantee of equipment performance.

Serving some of the leading names in industry

- |            |             |
|------------|-------------|
| BMW        | JCB         |
| Ford       | Caterpillar |
| Bosch      | NSK         |
| Honda      | Denso       |
| Bombardier | Perkins     |
| Volvo      | Geely       |

## Designing excellence

We have a track record of producing high quality products backed by a commitment to total customer satisfaction. Our technical application teams have a wealth of experience, thus ensuring many of our products are market leading innovations. All manufacturing is carried out under an ISO 9001 certified quality management system and we are accredited to ISO 14001 environmental standards.

## Unrivalled product range

We serve worldwide markets with an extensive product range including filtration systems, foreign body removal systems, magnet assemblies and complex magnetic industrial equipment used in industries such as automotive, aerospace and nuclear. Many of our products are unique and are covered by global patents.

## Worldwide support

We offer worldwide support through our offices in the UK, Canada and China with a network of technically trained partners providing local product support.

Eclipse Tools North America Inc., is a wholly owned subsidiary of Spear & Jackson PLC, and is responsible for the sales, distribution, and customer service of the Eclipse Magnetics range throughout North America.

# Contents

## **Who We Are**

Introduction to Eclipse Magnetics

**p2**

## **Magnetic Filtration Introduction**

Save time, save money, minimize waste

**p4 - 5**

## **Testimonials**

Hear what our customers have to say about magnetic filters

**p6 - 7**

## **Typical Applications**

How our products can solve problems & add value to your business

**p8 - 9**

## **Product Range & Bespoke Solutions**

Find the right solution for your application

**p10 - 21**

## **Installation & Technical Data**

Typical installation points & useful information

**p22 - 23**



# Driving competitive edge into precision processes

Our patented magnetic filtration systems are the ultimate in filtration technology, providing cost, quality and environmental benefits.

## Magnetic filtration operating principle

Magnetic filtration is the most effective means of removing problem ferrous particles from coolants and industrial fluids. Eclipse Magnetics provides a full range of coolant, oil, water, and industrial fluid filtration systems.

All the benefits of Eclipse Magnetic filters are based on their ability to remove virtually all ferrous particles, including sub-micron particles, without the need to replace consumable filters or affecting the fluids key properties. Traditional filtration systems typically leave particles smaller than 5-10 microns circulating in fluid, causing damage to the process equipment and finished product.

Magnetic filtration systems are ideal for either new build projects, capital projects, turnkey projects, or they can be installed to enhance existing filtration systems.

## Significantly lower operating costs

✓ Longer lasting fluids - Extends fluid life by x10

Magnetic filters can remove particles smaller than one micron in size. These particles significantly affect the performance of fluids and also act as a focus for bacterial build up.

✓ NO consumables - Cuts filter costs by up to 100%

Unlike other types of filtration, once magnetic filtration is installed there is nothing else you need to buy to ensure effective filtration over the filter's lifetime, which can be typically greater than 20 years.

✓ Minimal fluid loss and NO disposable costs

\* **Reduced environmental impact**

Contamination is removed from the filter as a semi-dry 'cake'. Fluid loss is considerably less than that of traditional filter media. The 'cake' itself can be recycled, eliminating expensive specialist disposable costs.

✓ Minimal running costs - Virtually zero

Manually cleaned magnetic filters require no additional power. Magnetic self-cleaning filters only require a small amount of power for the cleaning process.

✓ Ideal for 24/7 operation - Increase productivity

Fully automated magnetic filtration systems are ideal for continuous manufacturing lines.

✓ Rapid return on investment

Magnetic filtration is perfect for cost reduction and continuous improvement programmes providing a rapid return on investment.

✓ Health & safety

Minimal handling of contaminated fluid and bacterial growth.

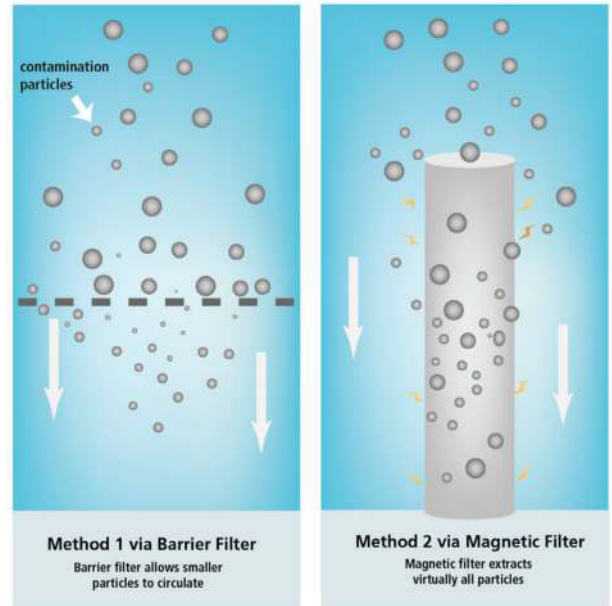

## Increase Productivity

### Maintain flow rates

High flow rates can be maintained without affecting filtration efficiency. Fluid does not flow through filter media, so flow is uninterrupted. Flow rates are determined by your process requirements, not by your filter.

### NO back pressure

Even when the filter is 'full' there is no blinding or risk of burst filters, reducing downtime.

### Reduced wear / precision finish

Particles that pass through traditional filters act as an abrasive, wearing parts, machinery and product. Magnetic filters remove these damaging particles.

### Fine filtration

Conventional filtration media, at 5 microns and below, can strip oils of anti-foaming, anti-bacteria and other additives. Magnetic filtration enables sub-micron filtration without affecting the oil's properties, and can actually aid the effective control of bacteria.

\*A major consideration for any business is its responsibility to the environment. Magnetic filtration is a positive contribution to companies' environmental policies and ISO14001 certification.



# Outperforms other filters

Magnetic filtration can be used as a replacement for, or in conjunction with, other forms of filtration to optimize filtration efficiency. *There are many types of filtration media, Eclipse Magnetics systems offer distinct advantages.*



## Typical filter type comparison

The table below shows how magnetic filtration compares to other forms of filtration in key performance criteria.

	Autofiltrex & Automag Skid	Micromag & Filtramag+	Magnetic rollers	Hydrocyclone/ centrifugal	Barrier (cartridges, paper)	Candle, powder	Settlement tanks	Vacuum
<b>Costs</b>								
Capital investment	medium	low	medium	very high	low	very high	high	high
Running costs	zero	zero	low	low	high	high	low	low
Return on investment	< 1	<1/2	2-5	5	never	10	5	10
<b>Performance</b>								
Filtration capability (micron)	< 1	< 1	> 20	> 10	> 20	> 10	> 100	>20
Process accuracy	very high	very high	low	medium	medium	high	low	medium
Flow rates (gpm or ltrs/min)	very high	very high	medium	low/medium	low	low	medium	medium

Note: This is general information for guidance purposes only. Please consult Eclipse Magnetics for application specific information.

# Give your business the edge. Hear from our customers...



“Before fitting Micromag we were changing filters every few days. We invested in 4 MM5s we estimate this saves us around \$52,000 annually in cartridge filter costs, not to mention the resultant downtime. Following the success we have now fitted Filtramags to our grinding machines which have cut our product reject rates to virtually zero.”

- Maintenance Engineer - Borg Warner (Turbocharger Balancing Machines)



“The Automag skid has exceeded our expectations; we are more than happy with its performance. 90% of swarf material is now being successfully removed from the oil, which is a massive improvement and results in plenty of cost savings for us.”

- Works Engineer - OSL Cutting Technologies (Tool Cutting)



“Micromag has paid back in just a few weeks, previously we could only take out particles of 50 microns or over, which caused the fluid channels to get plugged and drills to crash. Since I have fitted Micromag, my purchase of drill bodies has fallen by 100%. I am planning to fit Micromag to all my machines.”

- Plant Manager - Collison Goll (Deep Hole Drilling)



“The Double AM12 Skid has increased our efficiency. We work 24 hours a day and our 18" heads cut some big pieces of steel. Magnetic filtration has dramatically cleaned up our fluids and improved the surface finish we can offer. It extracts around 110lbs/50kg per day of ferrous waste and easily handles the flow and contamination generated by the multi-machine cell.”

- Facilities Manager - Milacron Machines (Sub-Contract Machining)





“This technology is economical, reliable and efficient. I believe that magnetic filtration technology is the future. ”

- Jonathan Michels at MMTCI -



“The waste removal process was taking up too much valuable time. The proper filtration system is just as, or even more important than operation speed. It saves time and money from having to stop the manufacturing process to clean the tank and repair jammed parts. The Filtrimag+ is very effective for what we needed.

I am truly surprised how much contamination we’re removing and how it’s improved our process. We are proud to say that there are currently 5 Filtrimag+ systems installed at Fruitland Manufacturing and we are thrilled to be a part of Eclipse’s growing process”

- Machine Shop Supervisor -  
Fruitland Manufacturing  
(CNC Machining)



“When we used only barrier filtration we had a constant problem with ‘blinding’ of the honing stone due to a build-up of ferrous particles. Fitting Micromag has been a real positive step, we can now guarantee a uniform high quality finish and our reject rates are minimal.”

- Operations Manager -  
NSK (Super-finishing of Bearing Hubs)



“Since the installation of a Micromag, the cartridge filter life has doubled and now requires changing only every two weeks. This will help the company save almost \$4,000 per year in disposable filter cartridges per machine. Wire on the EDM machine is also lasting longer, providing a cleaner cut. The machine fluid tank is now clean, as is the fluid itself, removing the requirement to dig out the tanks periodically.”

- Machine Operator -  
Spectra Premium (Wire EDM)



“We had a real problem with downtime as our quenching tank regularly filled up with ferrous contamination – we had to halt production and clean out the tank. Automag has been a smart investment. The automated cleaning frees up my maintenance team and we will get rapid payback through reduced process downtime.”

- Facilities Manager -  
Cascade (Heat Treatment of  
Fork Lift Parts)



# Why industries choose magnetic filtration.

## Automotive

Magnetic filtration is widely used in the automotive industry within OEMs and tier 1 and 2 suppliers for the manufacture of powertrain and engine components.



### Advantages

- High precision finish
- Reduced downtime
- 100% effective with cast iron particles
- Ideal for 24/7 operation
- Flow rates up to 18~2600 gallons/min. (10,000 ltrs/min.): multi-use to increase flow capacity

### Typical Application

- Ring & pinion gear lapping
- Turbocharger balancing machines
- Crank shaft gun drilling
- Valve face grinding
- Cam shaft grinding
- Cylinder liner honing
- Engine liner grinding
- Gear cutting and finishing

### Case study

**Company**  
Bombardier (Austria)

**Application**  
Cast iron piston bushings

**Process**  
Milling and gun drilling  
Filtramag removed sub-micron particles reducing abrasive wear on tools and parts. Tool changes and product reject rates were reduced to virtually zero.

## Bearings

Magnetic filtration is used by some of the world's largest bearing manufacturers to ensure sub-micron accuracy in the production of bearing components.



### Advantages

- High precision product finish, concentricity and consistency
- Reduced downtime
- Sub-micron filtration
- Ideal for high volume processes
- Can be retrofitted to existing lines
- Rapid return on investment
- Reduced waste – ISO14001

### Typical Application

- Hub honing
- Ball grinding
- Super-finish/polishing
- Ring grinding
- Raceway grinding
- Wash systems

### Case study

**Company**  
Tsubaki-Hoover (Poland)

**Application**  
Steel ball and rollers

**Process**  
Super-finishing  
Micromag improved on 20 micron paper filters by extracting sub-micron ferrous particles. Surface finish was improved and reject rates fell dramatically.

## Wash systems

It is vital that wash solutions are kept free from ferrous particles. Many wash systems have benefitted from installation of magnetic filtration which ensures the finished product is clean and complies with quality inspection.



### Advantages

- Flow rates up to 18~2600 gallons/min. (10,000 ltrs/min.)
- Filters do not degrade in wash solutions
- Removes ferrous deposits from finished product
- Reduces reject rates

### Typical Application

- Rotary wash systems
- Transfer wash stations
- Degreasing equipment
- Multi-stage washers
- Spray wash stations

### Case study

**Company**  
Permoid (UK)

**Application**  
Automotive fuel tanks

**Process**  
Flushing rig  
Reduced product reject rates to zero, reduced disposal and purchase of barrier filters by 95%.



# Steel processing

Magnetic filtration can improve efficiency in most steel processing operations such as steel production, both hot and cold.



## Advantages

- Automated cleaning ideal for heavy contamination
- Improved surface finish
- Reduced downtime
- Suitable for arduous environments
- 24/7 operation

## Typical Application

- Steel rolling mills
- Sawing machines
- Steel pipe cutting
- Tube threading equipment
- Steel quenching tanks
- Surface treatment processes
- Spray bars
- Roller lubrication
- Final wash process
- Deep hole drilling

## Case study

Company  
Steelscape (USA)

Application  
Steel rolling and pickling

Process  
Surface spray system  
Heavy contamination blocked barrier filters within hours. Automag extracts 30000 lbs (12000 kg) contamination / month – reject rates have fallen to zero.

# Machine tool OEMs

Magnetic filtration enhances performance on a variety of machine tools. It offers a competitive edge to machine tool manufacturers particularly when servicing high precision applications.



## Advantages

- Can be retrofitted to enhance existing filtration systems
- Reduces machine maintenance/downtime
- Flow rates 8~2600 gallons/min. (70 to 10,000 ltrs/min.)
- 100% effective with low magnetic materials e.g. cast iron and tungsten carbide
- Increases the equipment, value provides a solution for the customer

## Typical Application

- VMC, HMC, and CNC machines
- Multi-axis vertical turning centres
- Grinding
- Honing
- Lapping
- Deep hole/gun drilling
- EDM machines
- Laser cutters

## Case study

Company  
Schaut Mikrosa (Germany)

Application  
CNC Manufacture

Process  
Camshaft grinding  
Reduced downtime by 50% and increased the life of grinding wheels by 30%.

# Tool cutting

High intensity magnetic filtration is the only option available to guarantee a high precision finish on tool cutting operations.



## Advantages

- Enables tolerances of < 1 micron
- Enables manufacture of "mirror" finish tools
- Can increase the value of tools by 300%
- 100% effective with low magnetic materials e.g. tungsten carbide materials
- Reduces wear on grinding wheels
- Ensures clear grinding contact
- Ideal for 24/7 or unmanned operations
- Significantly extends fluid life

## Typical Application

- Multi axes CNC machines
- Tungsten carbide drills and endmills
- Radius grinding
- Wood working tool superfinish
- "Mirror" finish plastic cutters

## Case study

Company  
Pro-Cut Tooling (UK)

Application  
Carbide cutting tools manufacture/repair

Process  
Super-finish/grinding  
Enabled manufacture of "mirror" finish cutting tools, reduced machine cleaning downtime by 75% and extended fluid life by 250%.

PATENTED DESIGN

# Micromag



**Compact magnetic filter, easy to clean and install, high collection capacity relative to size.**

**Key**

- Contaminated fluid
- Filtered fluid
- Magnetic flux lines

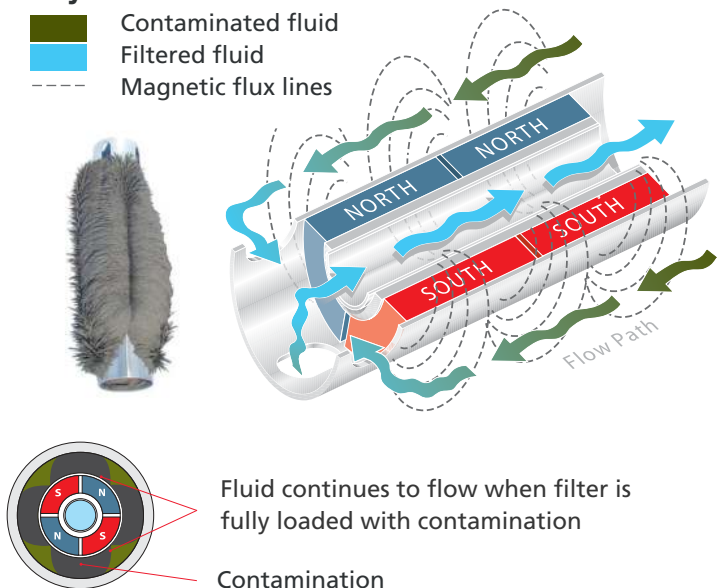

**How Micromag works**

Contaminated fluid enters the inlet port where flow is equally split via tapered radial flow channels which lowers the flow velocity ready for the fluid to be filtered.

It then passes up the outside of the centrally mounted 'Rare Earth' magnetic core where contamination particles are attracted and retained.

The magnetic flux circuit geometry ensures a controlled build up of contamination so the filter can never block.

Filtered fluid then flows through slots at the top of the core then down and through the centre of the core, exiting through the outlet port.



### MM - 174 psi version

MM5/1.0 | MM10/1.0 | MM20/1.5



### MM - 725 psi version

MM5/HP/50NPT | MM10/HP/50NPT | MM20/HP/50NPT



### MM - 1160 psi version

MM5/HP/80NPT | MM10/HP/80NPT | MM20/HP/80NPT

## Technical Data

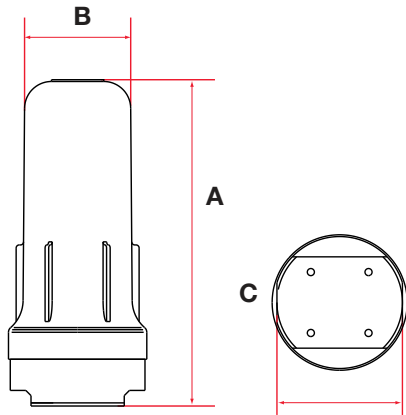

Product number	Flow rate	Max. operating pressure	Connection	Temperature range	Construction	Dimensions inches		
	gallons/min.					psi	NPT"	°F
MM5/1.0	18	174	1	41 - 122	SAN housing, Aluminum lid	7.5	3.7	4.1
MM10/1.0	26	174	1			12.4	4.0	4.9
MM20/1.5	40	174	1½			23.9	4.0	5.3
MM5/HP/50NPT	18	725	1	41 - 284	Full Aluminum construction	9.7	4.6	4.9
MM10/HP/50NPT	26	725	1			14.3	4.6	4.9
MM20/HP/50NPT	40	725	1½			24.6	4.6	4.9
MM5/HP/80NPT	18	1160	1	41 - 284	Full Stainless Steel construction	9.7	4.6	4.9
MM10/HP/80NPT	26	1160	1			14.3	4.6	4.9
MM20/HP/80NPT	40	1160	1½			24.6	4.6	4.9
METRIC	ltrs/min.	bar	NPT"	°C	Construction	mm		
MM5/1.0	70	12	1	5 - 50	SAN housing, Aluminum lid	190	95	103
MM10/1.0	100	12	1			315	100	124
MM20/1.5	150	12	1½			605	100	137
MM5/HP/50NPT	70	50	1	5 - 140	Full Aluminum construction	247	116	125
MM10/HP/50NPT	100	50	1			365	116	125
MM20/HP/50NPT	150	50	1½			625	116	125
MM5/HP/80NPT	70	80	1	5 - 140	Full Stainless Steel construction	247	116	125
MM10/HP/80NPT	100	80	1			365	116	125
MM20/HP/80NPT	150	80	1½			625	116	125



PATENTED DESIGN

# Filtramag+



Easy access for gloved hand

Patented high intensity magnetic rods & flow circuit

Parallel inlet and outlet

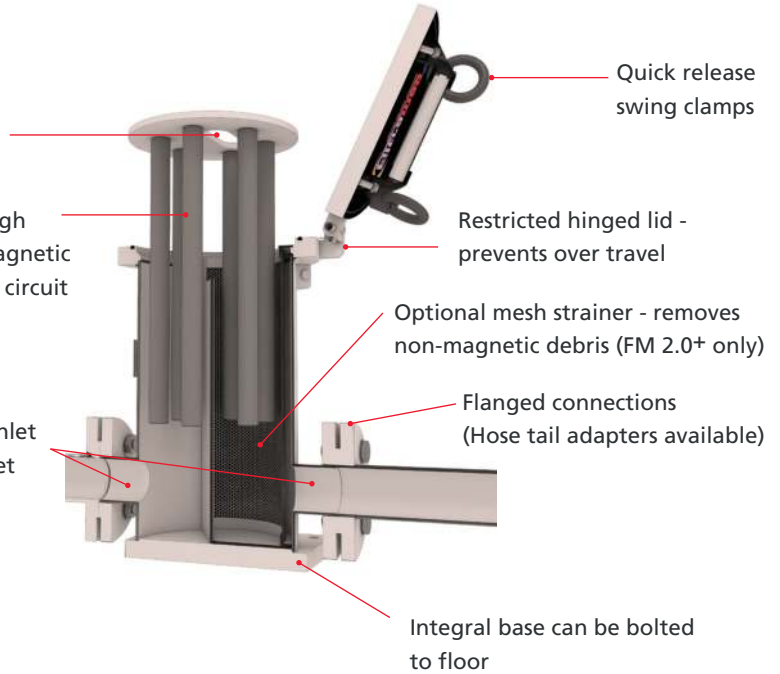

**Robust high performance magnetic filter with Dual Flow Technology to maximize collection capability. Easy installation with operation up to 290 psi (20 bar).**



**Ideal for use in harsh chemical environments. Effective with carbide and cast iron applications.**

## Special applications

For processes with high levels of contamination, high fluid flow rates, high viscosity fluids or that operate continuously, multiple Filtramag+ filters can be installed in parallel using a manifold. Each Filtramag+ can be isolated, using a manual valve and cleaned without stopping the process.

# How Filtramag+ works

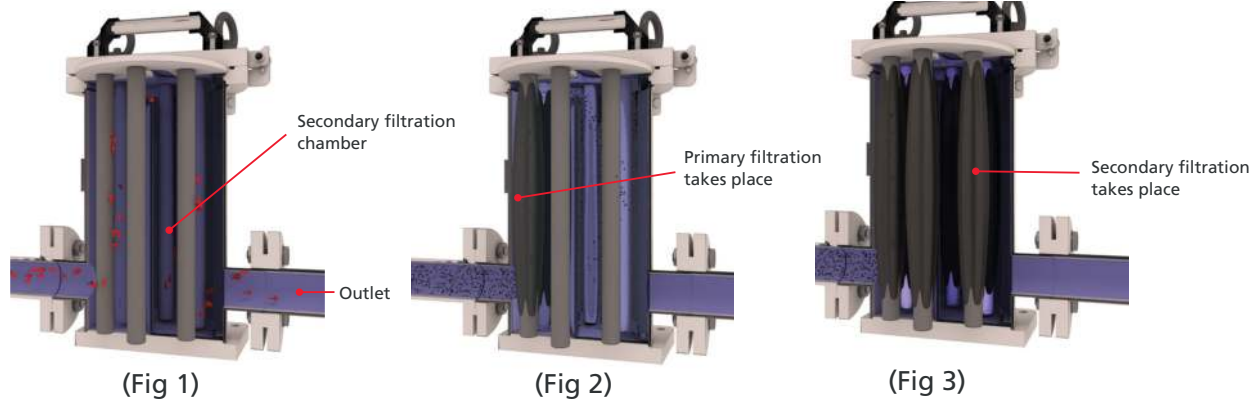

With a unique "Dual Flow Technology™" design (Fig 1) Filtramag+ is the most efficient filter of its type available. The dual flow design ensures that fluid is exposed to the high intensity magnets for the maximum time, thus ensuring almost 100% of ferrous contamination is removed on the first pass. Fluid enters through the inlet and flows through the primary filtration chamber, (Fig 2) it then flows down through the secondary filtration chamber (Fig 3).

Fluid then passes through an optional mesh screen which removes non-magnetic debris. The patented magnetic circuit design ensures that the filter can never block even in high contamination applications. The magnetic cores can be removed easily by hand and cleaned with the tool supplied. As an option a spare magnetic cartridge can be supplied to ensure production continuity.

## Technical Data

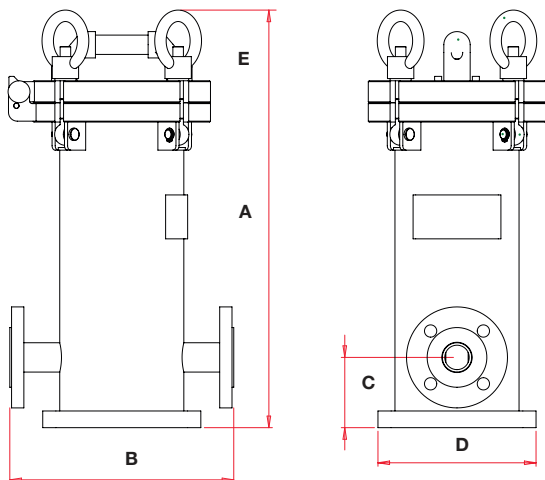

Product number	Max. flow rate gallons/min.	Max. operating pressure psi	Connection ANSI"	Dimensions inches					Magnetic strength gauss
				A	B	C	D	E	
FM1.5+/ANSI	66	290	1½"	15.5	10.0	3.9	7.1	3.2	4,000
FM2.0+/ANSI	132	290	2"	17.1	13.0	3.9	9.8	3.2	4,000
FM1.5+/ANSI/11K	66	290	1½"	15.5	10.0	3.9	7.1	3.2	11,000
FM2.0+/ANSI/11K	132	290	2"	17.1	13.0	3.9	9.8	3.2	11,000
METRIC	ltrs/min.	bar	ANSI"	mm					gauss
FM1.5+/ANSI	250	20	1½"	395	255	100	180	80.5	4,000
FM2.0+/ANSI	500	20	2"	442	330	100	250	80.5	4,000
FM1.5+/ANSI/11K	250	20	1½"	395	255	100	180	80.5	11,000
FM2.0+/ANSI/11K	500	20	2"	442	330	100	250	80.5	11,000

# Filtramag+ Mobile

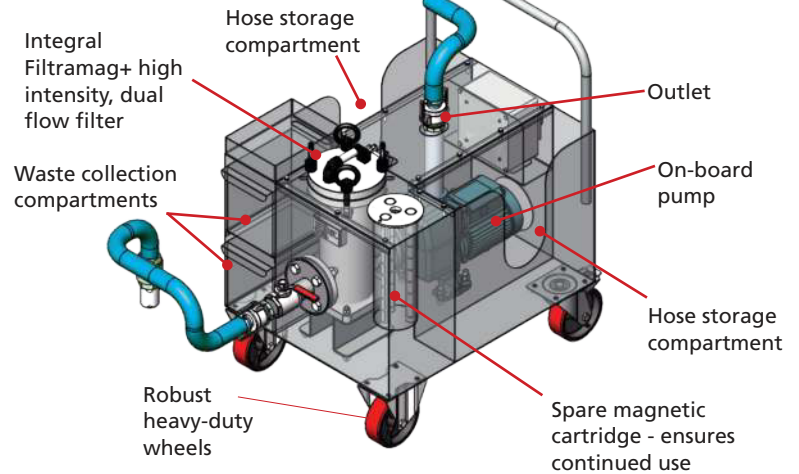

An off-line filtration system for cleaning oils and coolants. This 'Plug & Play' unit offers efficient sub-micron filtration & can be moved easily from machine to machine.

## Typical applications

- Ferrous machining processes
- Tank draining
- Tank cleaning
- Overnight fluid cleaning
- Additional filtration
- Incoming fluid inspection
- Carbide applications



Waste collection & recycling

## Benefits

- Simple, "Quick-Connect" installation
- High performance, sub-micron filtration
- Cleaner, longer lasting fluids
- Cost savings in disposable filter usage
- Improved surface finish and accuracy
- Reduced waste disposable and oil wastage



Spare magnetic core included



# Convenient 'Plug & Play' Mobile Filtration



## Technical Data

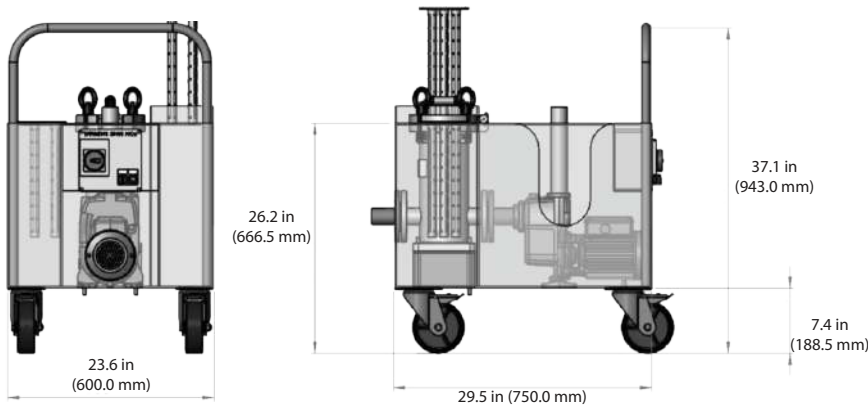

## Construction

Magnet material: Rare Earth Neodymium Iron Boron (NdFeB)  
Magnet grade: N35 (standard), N45 (optional)  
Filter housing: 304 grade stainless steel (powder coated)  
Unit body: Mild steel (painted)  
Pump: Self priming AM 40-110B, single phase, 110V, 60HZ  
Power: 13 amp, 3 pin socket (other options available)  
Hoses: 9ft (3m) long inlet and outlet hoses included, made from oil resistant PVC material, supplied with Cam lock connections.

## Performance

Flow rate: 66 gallons/min. (250 ltrs/min.) | Magnetic performance: 4,000 Gauss (standard), 11,000 Gauss (optional)  
Contamination collection capacity: 6.6 lbs (3kgs) | Operating temperature: 41°F to 140°F ( 5°C to 60°C) | Maximum suction height: 12.9m

# Autofiltrex



\*Waste reclaim unit

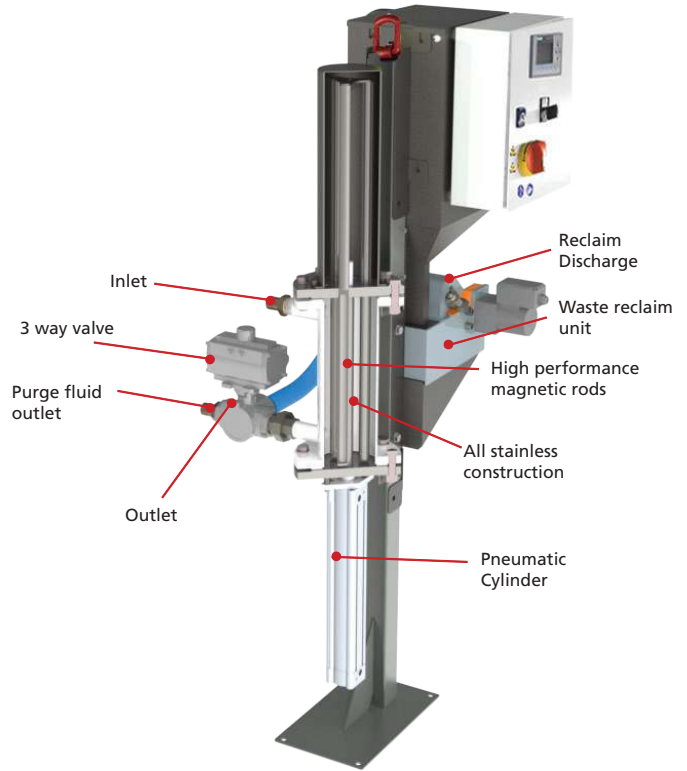

Inlet  
3 way valve  
Purge fluid outlet  
Outlet  
Reclaim Discharge  
Waste reclaim unit  
High performance magnetic rods  
All stainless construction  
Pneumatic Cylinder

The latest generation in cost-effective fluid filtration.  
Fully automated operating & cleaning. Provides huge cost savings in fluids & filter consumables.

## Typical applications

Autofiltrex is ideal for most ferrous machining applications such as:

- Honing
- Lapping
- Grinding
- Forming
- Quenching processes

## Benefits

- Cleaner fluid delivery to the machine
- Reduced expenditure on filter media
- Fully automated cleaning
- Reduced waste disposal
- Increased fluid lifespan
- Improved surface finish and accuracy
- 24/7 uninterrupted filtration
- Minimal space required

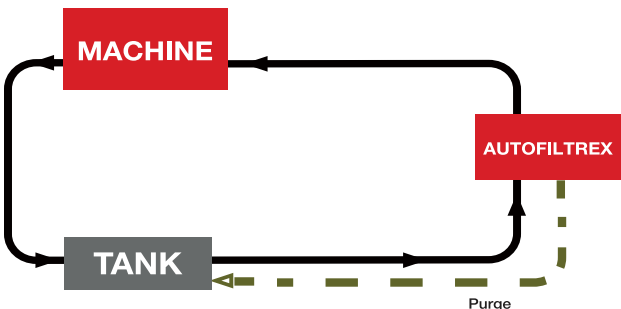

# How Autofiltrex Works

Autofiltrex works in-line, taking dirty fluid from the holding tank and delivering clean polished fluid to the tool/workpiece contact point. As fluid flows through the Autofiltrex cylinder, high intensity magnetic circuits extract ferrous contamination particles.

When the magnets reach saturation point, a timed automated purging process lifts the magnetic cores from the housing thereby releasing contamination. This is simultaneously diverted via a 3-way valve to the reclaim unit. The unit can be set to purge at timed intervals or be manually executed.



AF3/RC/110

AF5/RC/110

## Technical Data

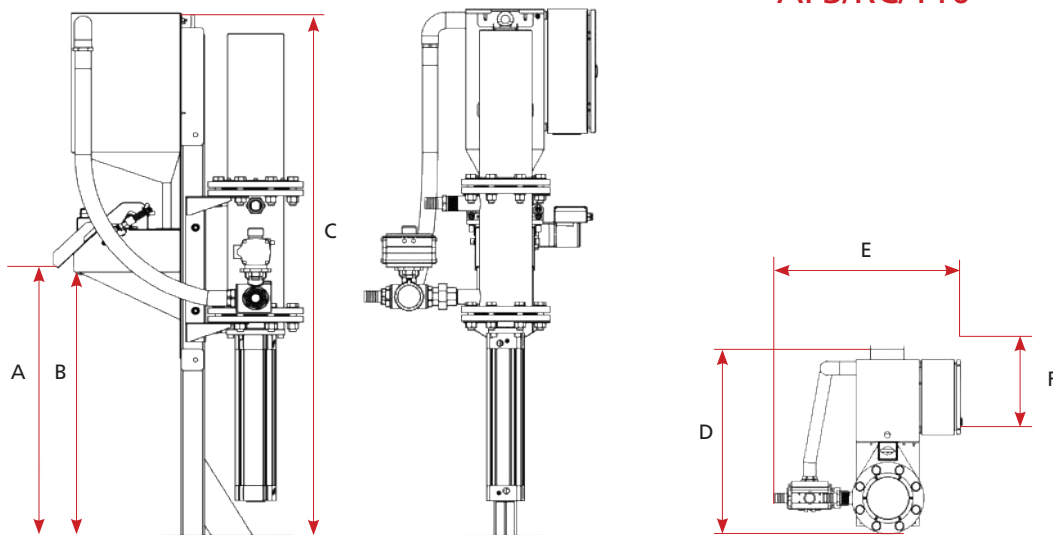

Product number	Flow rate gallons/min.	Number of magnetic rods	Magnetic strength gauss	Connections Hosetail inches	Contamination capacity lbs	Weight lbs	Dimensions inches					
							A	B	C	D	E	F
AF3/RC/110	40	3	9,000	1.25	6.6	269	34.3	33.5	66.9	28.2	27.5	11.8
AF5/RC/110	53	5	9,000	1.50	11.0	320	34.3	33.5	66.9	29.4	29.4	11.8
METRIC	ltrs/min.		gauss	mm	kgs	kgs	mm					
AF3/RC/110	150	3	9,000	31	3	122	872	852	1701	717	698	300
AF5/RC/110	200	5	9,000	38	5	145	872	852	1701	747	747	300



PATENTED DESIGN

# Automag Skid

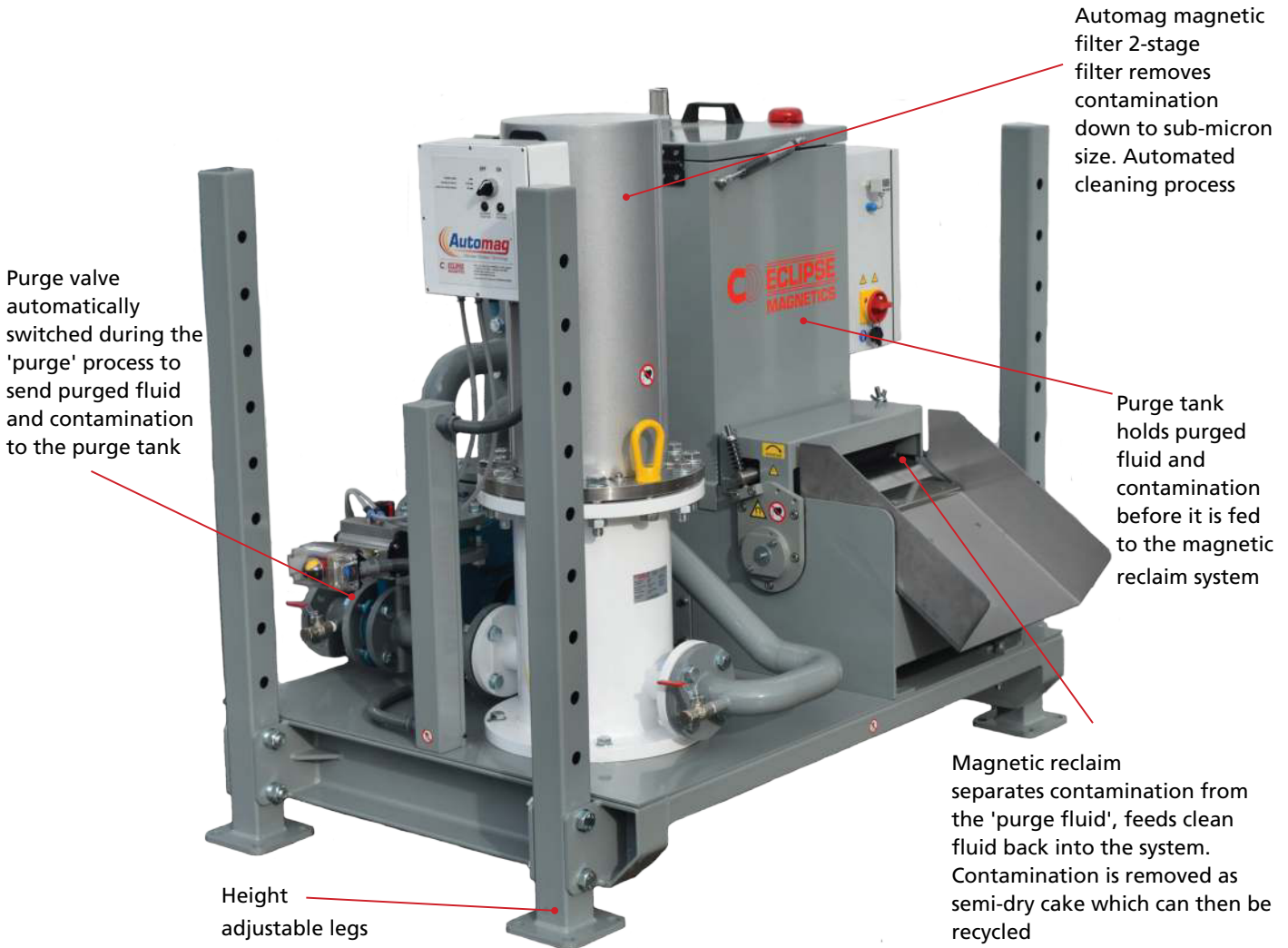

Automag magnetic filter 2-stage filter removes contamination down to sub-micron size. Automated cleaning process

Purge valve automatically switched during the 'purge' process to send purged fluid and contamination to the purge tank

Purge tank holds purged fluid and contamination before it is fed to the magnetic reclaim system

Magnetic reclaim separates contamination from the 'purge fluid', feeds clean fluid back into the system. Contamination is removed as semi-dry cake which can then be recycled

Height adjustable legs

**Self-contained, free standing magnetic filtration system. Providing uninterrupted 24/7 filtration. Can be used in-line or with optional integral pump, off-line.**

## How Automag works

An Automag magnetic filter removes magnetic and para-magnetic contamination and holds it until it is released during the automated 'purge' process. Then, the filter's output is briefly diverted so that fluid carries the contamination to the purge tank.

The purge tank then feeds the contaminated fluid to the magnetic reclaim which removes the contamination, putting clean fluid back into circulation. The contamination is extracted in a form ready for disposal or recycling.

Units can be supplied with a single filter or double filters for duplex operation.



Dual flow technology™ ensures that fluid is exposed to the high intensity magnets for the maximum time, thus ensuring almost 100% of ferrous contamination is removed on the first pass.



Contamination is attracted to the tube of the cores. Cleaned fluid is re-circulated.



Compressed air lifts the cores from the tubes and the purge valve is opened. Contamination is released and washed away for collection.



AM6 Skid



AM12 Skid

AM6 Skid	Model	Pump	PLC	Purge Valves	Reclaim Recovery
AM6S1	Single AM6 Skid		✓	✓	✓
AM6S1/P	Single AM6 Skid	✓	✓	✓	✓
AM6S2	Double AM6 Skid		✓	✓	✓
AM6S2/P	Double AM6 Skid	✓	✓	✓	✓

AM12 Skid	Model	Pump	PLC	Purge Valves	Reclaim Recovery
AM12S1	Single AM12 Skid		✓	✓	✓
AM12S1/P	Single AM12 Skid	✓	✓	✓	✓
AM12S2	Double AM12 Skid		✓	✓	✓
AM12S2/P	Double AM12 Skid	✓	✓	✓	✓

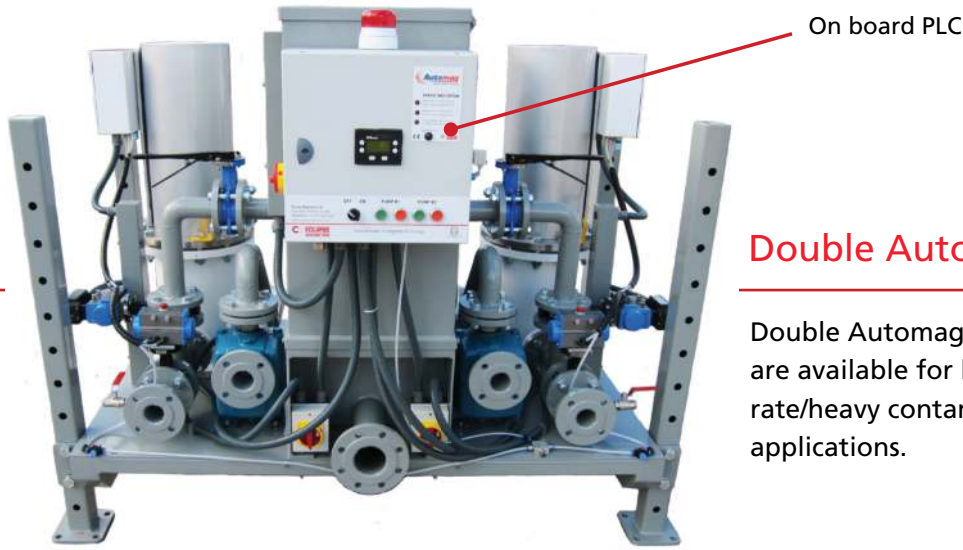

## Double Automag Skid

Double Automag Skid units are available for large flow rate/heavy contamination applications.

## Technical Data

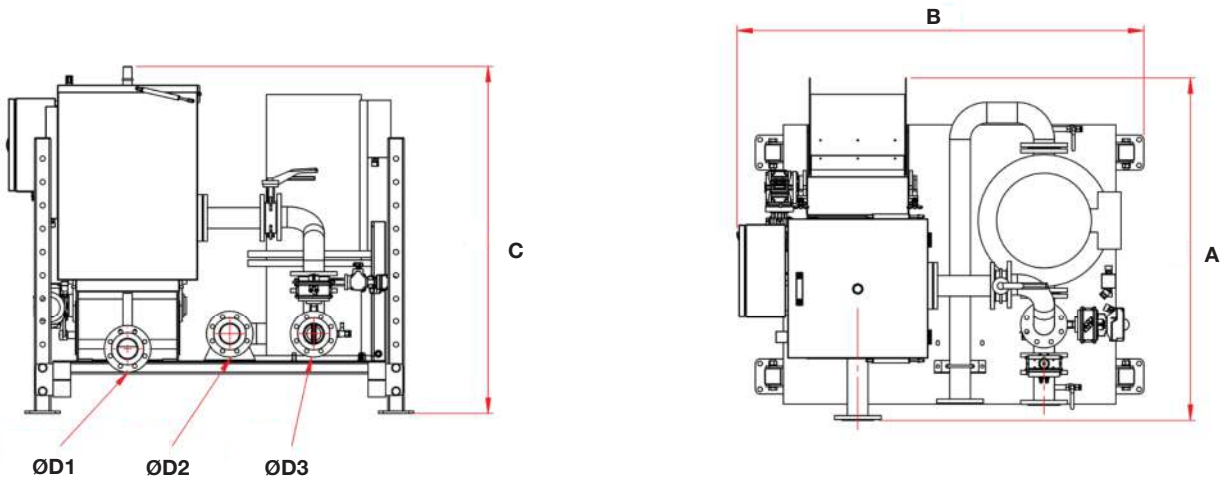

Model	Number of cores	Maximum flow rate		Contamination capacity lbs	Max. operating pressure psi	Dimensions inches						
		gallons/min.	ft <sup>3</sup> /hour			A	B	C	D1	D2	D3	Flanges
AM6 Skid Single	6	119	954	15	145	51.2	60.6	50.8 / 86.2	3	2	2	ANSI
AM6 Skid Double	12	238	1907	30	145	51.2	89.4	50.8 / 86.2	3	2	2	ANSI
AM12 Skid Single	12	238	1907	30	145	57.8	68.6	58.7 / 94.1	3	3	3	ANSI
AM12 Skid Double	24	476	3814	60	145	57.8	97.4	58.7 / 94.1	3	3	3	ANSI
METRIC		ltrs/min.	m <sup>3</sup> /hour	kgs	bar	mm						Flanges
AM6 Skid Single	6	450	27	6	10	1300	1540	1290 / 2190	75 (3")	50 (2")	50 (2")	ANSI
AM6 Skid Double	12	900	54	12	10	1300	2272	1290 / 2190	75 (3")	50 (2")	50 (2")	ANSI
AM12 Skid Single	12	900	54	12	10	1469	1743	1490 / 2390	75 (3")	75 (3")	75 (3")	ANSI
AM12 Skid Double	24	1800	108	24	10	1469	2475	1490 / 2390	75 (3")	75 (3")	75 (3")	ANSI





## Special Designs - AM32

AM32 is available for wash system applications up to 1057 gallons per minute (4,000 litres per minute) flow rate (contact us for details).

## Case Study

Industry: Tool Manufacturing  
 Process Type: Grinding hand hacksaw blades  
 Location: Jiangmen, South China  
 Eclipse Product Installed: Automag 6 Skid  
 Machined Material: M2 Steel

### The Challenge

As a brand new machine, the creep feed grinder was fitted with a paper filter roll. In addition to being expensive when replaced regularly, the paper filters become contaminated by metal swarf quickly.

Staff at the manufacturing facility decided to add an extra level of filtration in the form of a magnetic filter to capture and remove ferrous particles from the coolant.

### The Solution

Eclipse Magnetics provided an Automag Skid magnetic filtration system. The AM6 Automag filter unit boasts 6 magnetic cores, and a maximum flow rate of 119 gallons per minute (450 litres per minute). With a contamination capacity of up to 15 lbs (7kg), the AM6 has a maximum operating pressure of up to 145 psi (10 bar).

The magnetic filter now removes the contamination before it reaches the paper filter, preventing it from clogging up and needing to be replaced frequently.

### Results

The Automag Skid removes magnetic and para-magnetic contamination, down to sub-micron size, from the coolant used in the creep feed grinding machine. Therefore, the magnetic filter helps extending the life of the paper filter significantly, in turn saving money and reducing waste.



Photo: The contamination is dry when it is reclaimed.



# Installation Options

## Pre-Filtration Installation - With Bypass

Protect:

- High pressure pump
- Media filter (bags, cartridges, beds, etc)
- Machine tool: through spindle components, tooling, keep sump clean, reduce wearing of part (way covers), extend coolant/oil life with no loss of physical properties

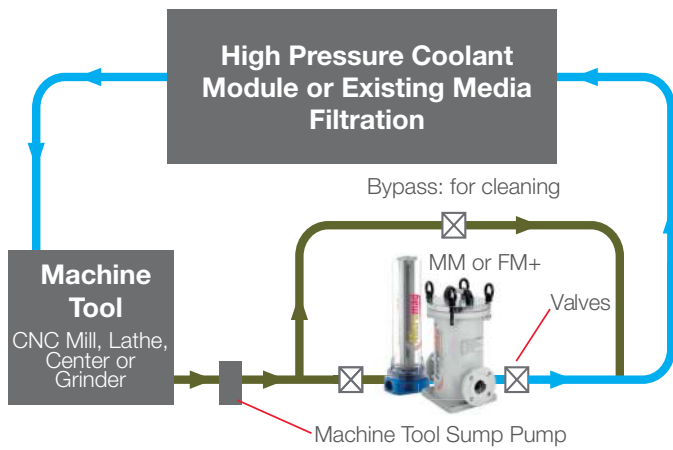

## Pre-Filtration Installation - Duplex

Advantages:

- Ease of cleaning
- Duplex magnetic filter
- Constant high efficiency filtration

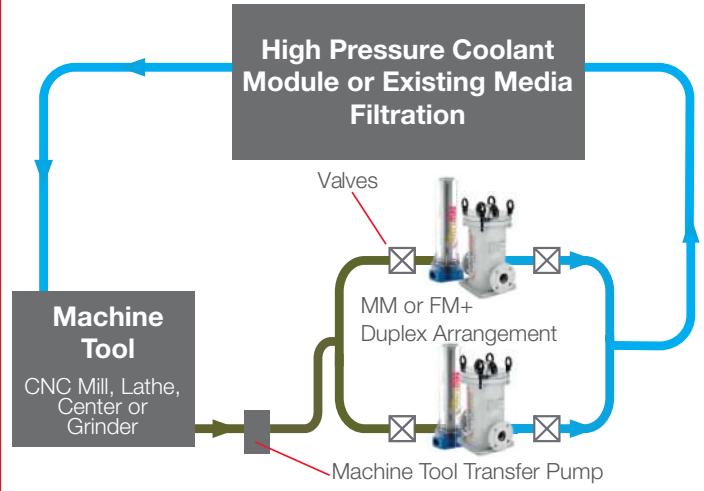

## Kidney Loop Filtration 24/7 Uninterrupted Cleaning

Protect:

- Tooling
- Keep sump clean
- General system cleanliness
- Extend coolant life (with no loss of physical properties)

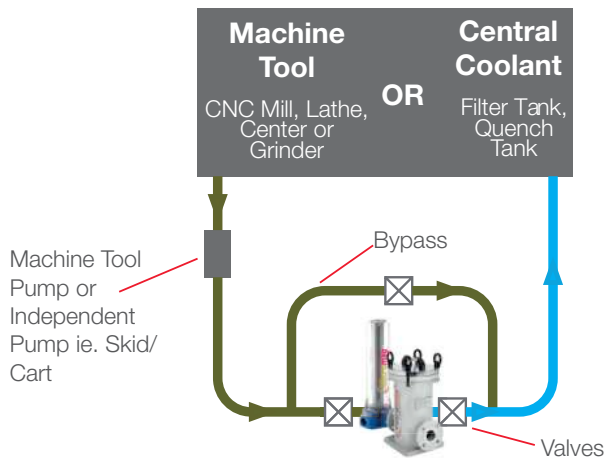

## Post Filtration Installation - With Bypass Coolant Polishing

Protect:

- Machine tool: through spindle components, tooling, extend coolant/oil life with no loss of physical properties, keep sump clean, and reduce wearing of parts (linear bearings)

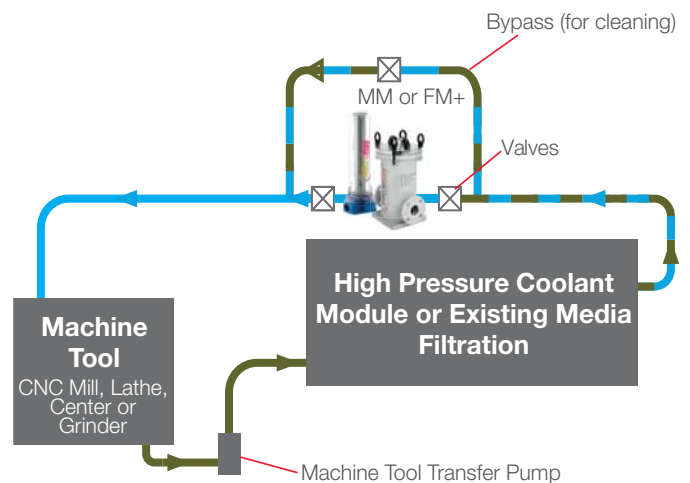

# Application Data Selector

Percentage reduction required from stated maximum flow rate to obtain good filtration results

Part No	Flow rates		Fluid Type				Material Type						Material Loading			
	gallons/min.	ltrs/min.	Coolant/Wash solution	Thin oil	Medium oil	Thick oil	Mild steel	Hard steel	Cast iron	Stainless steel	High speed steel	Tungsten carbide	Heavy	Medium	Light	Wear
<b>Manual</b>																
<b>Micromag</b>																
MM5/1.0	18	70	0	20	n/a	n/a	0	n/a	20	n/a	n/a	n/a	n/a	n/a	n/a	✓
MM10/1.0	26	100	0	20	n/a	n/a	0	30	20	n/a	n/a	n/a	n/a	n/a	✓	✓
MM20/1.5	40	150	0	20	30	60	0	30	20	70	n/a	n/a	n/a	✓	✓	✓
<b>Automated</b>																
<b>Autofiltrex</b>																
AF3/RC/110	40	150	0	10	20	40	0	20	20	50	60	70	✓	✓	✓	✓
AF5/RC/110	53	200	0	10	20	40	0	20	20	50	60	70	✓	✓	✓	✓
<b>Automag Skid</b>																
AM6S1	119	450	0	10	20	30	0	20	20	40	50	60	✓	✓	✓	n/a
AM12S1	238	900	0	10	20	30	0	20	20	40	50	60	✓	✓	✓	n/a
AM6S2	238	900	0	10	20	30	0	20	20	40	50	60	✓	✓	✓	n/a
AM12S2	476	1800	0	10	20	30	0	20	20	40	50	60	✓	✓	✓	n/a

## Example:

Filter	FM2.0 <sup>+</sup> /ANSI	132 gallons/min. (500 ltrs/min.) × Medium oil (20%) = 106 gallons/min. (400 ltrs/min.)
Flow	132 gallons/min. (500 ltrs/min.)	106 gallons/min. (400 ltrs/min.) × Cast iron (20%) = 85 gallons/min. (320 ltrs/min.)
Material	Cast iron	Suggested flow rate = 85 gallons/min. (320 ltrs/min.)
Fluid	Medium oil	

## Centipoise

Thin oil	20–300
Medium oil	300–700
Thick oil	700+

## Other Products

In addition to our filtration range, Eclipse Magnetics manufacture a wide range of high performance magnetic products for diverse applications.



Workholding systems



Lifting and handling systems



Magnetic aids for workshop & general engineering applications



Magnetic materials & assemblies

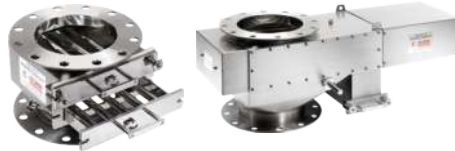

Foreign body removal - Separation & detection systems



Heating system filters

## Eclipse Magnetics Worldwide

### Americas

442 Millen Road, Unit 9  
Stoney Creek  
Ontario, L8E 6H2  
Canada

T 1-800-260-2124  
F 1-800-260-1410  
sales@eclipsetoolsinc.com

### Europe

Atlas Way  
Sheffield  
S4 7QQ  
England

T 0044 (0)114 225 0600  
F 0044 (0)114 225 0610  
info@eclipsemagnetics.com

### China

No. 168 Chengjian Road  
Minhang District  
Shanghai  
PR China

T (0086) 21 6434 8600 \*150  
F (0086) 21 6434 6488  
szhou@eclipsemagnetics.com

Representative:

[www.eclipsemagnetics.com/na](http://www.eclipsemagnetics.com/na)

Eclipse Tools North America Inc.

442 Millen Road, Unit 9 | Stoney Creek | ON L8E 6H2

☎ 1-800-260-2124 📠 1-800-260-1410 🔍 [www.eclipsemagnetics.com/na](http://www.eclipsemagnetics.com/na) ✉ sales@eclipsetoolsinc.com



While every effort has been made to ensure the accuracy of the information in this publication, please note that specifications may change without notice. V14

